

Duct sensor Humidity / Temperature

Active sensor (4...20 mA) for measuring the relative or absolute humidity and temperature in duct applications. Instead of the humidity signal, the enthalpy or the dewpoint can be selected as an output signal. IP65 / NEMA 4X rated enclosure.



Type Overview

Type	Output signal active temperature	Output signal active humidity	Probe length
22DTH-13M	4...20 mA	4...20 mA	140 mm
22DTH-13Q	4...20 mA	4...20 mA	270 mm

Technical Data

Electrical data	Nominal voltage	DC 24 V		
	Nominal voltage range	DC 13.5...26.4 V		
	Power consumption DC	0.5 W		
	Electrical connection	Pluggable spring loaded terminal block max. 2.5 mm ²		
	Cable entry	Cable gland with strain relief Ø6...8 mm		
Functional data	Sensor Technology	Polymer capacitive sensor with stainless steel wire mesh filter		
	Multirange	4 measuring ranges selectable		
	Current output	2x 4...20 mA, max. load 500 Ω		
	Application	Air		
Measuring data	Measuring values	Relative humidity Absolute humidity Dew point Enthalpies Temperature		
	Measuring range humidity	0...100% RH non-condensing		
	Measuring range temperature	Active sensor: range selectable Attention: max. measuring temperature is restricted by max. fluid temperature (see Safety data)		
		Setting	range [°C]	range [°F] Factory setting
		S0	-40...60	-40...160
		S1	0...50	40...140
		S2	-15...35	0...100
		S3	-20...80	0...200
	Measuring range absolute humidity	adjustable at the transducer: 0...50 g/m ³ (default setting) 0...80 g/m ³		
	Measuring range enthalpy	0...85 kJ/kg		
Measuring range dew point	adjustable at the transducer: 0...50°C (default setting) -20...80°C			
Accuracy humidity	Typical ±2% between 10...90% RH @ 21°C			

	Accuracy temperature active	$\pm 0.5^{\circ}\text{C}$ @ 21°C [$\pm 0.9^{\circ}\text{F}$ @ 70°F]
	Long-term stability	$\pm 0.3\%$ RH p.a. @ 21°C @ 50% RH $\pm 0.05^{\circ}\text{C}$ p.a. @ 21°C [$\pm 0.09^{\circ}\text{F}$ p.a. @ 70°F]
	Time constant τ (63%) in air duct	Relative humidity: typical 10 s @ 3 m/s Temperature: typical 125 s @ 3 m/s
Materials	Cable gland	PA6, black
	Housing	Cover: Lexan, orange Bottom: Lexan, orange Seal: 0467 NBR70, black UV resistant
Safety data	Ambient humidity	Max. 95% r.H., non-condensing
	Fluid humidity	Short-term condensation permitted
	Ambient temperature	$-35\text{...}50^{\circ}\text{C}$ [$-30\text{...}120^{\circ}\text{F}$]
	Fluid temperature	$-40\text{...}80^{\circ}\text{C}$ [$-40\text{...}175^{\circ}\text{F}$]
	Operating condition air flow	max. 12 m/s
	Protection class IEC/EN	III Safety Extra-Low Voltage (SELV)
	Protection class UL	UL Class 2 Supply
	EU Conformity	CE Marking
	Certification IEC/EN	IEC/EN 60730-1
	Certification UL	cULus acc. to UL60730-1A/-2-9/-2-13, CAN/CSA E60730-1:02/-2-9
	Degree of protection IEC/EN	IP65
Degree of protection NEMA/UL	NEMA 4X	
Quality Standard	ISO 9001	

Safety notes

This device has been designed for use in stationary heating, ventilation and air-conditioning systems and must not be used outside the specified field of application. Unauthorised modifications are prohibited. The product must not be used in relation with any equipment that in case of a failure may threaten humans, animals or assets.

Ensure all power is disconnected before installing. Do not connect to live/operating equipment.

Only authorised specialists may carry out installation. All applicable legal or institutional installation regulations must be complied during installation.

The device contains electrical and electronic components and must not be disposed of as household refuse. All locally valid regulations and requirements must be observed.

Remarks

General remarks concerning sensors Sensing devices with a transducer should always be operated in the middle of the measuring range to avoid deviations at the measuring end points. The ambient temperature of transducer electronics should be kept constant. The transducers must be operated at a constant supply voltage ($\pm 0.2\text{ V}$). When switching the supply voltage on/off, onsite power surges must be avoided.

Build-up of Self-Heating by Electrical Dissipative Power

Temperature sensors with electronic components always have a dissipative power which affects the temperature measurement of the ambient air. The dissipation in active temperature sensors shows a linear increase with rising operating voltage. The dissipative power should be taken into account when measuring temperature. In case of a fixed operating voltage (± 0.2 V) this is normally done by adding or reducing a constant offset value. As Belimo transducers work with a variable operating voltage, only one operating voltage can be taken into consideration, for reasons of production engineering. Transducers 0...10 V / 4...20 mA have a standard setting at an operating voltage of DC 24 V. That means, that at this voltage, the expected measuring error of the output signal will be the least. For other operating voltages, the offset error will be increased by a changing power loss of the sensor electronics.

If a readjustment directly at the active sensor should be necessary during later operation, this can be done with the following adjustment methods.

- For sensors with NFC or dongle by the corresponding Belimo app
- For sensors with a trimming potentiometer on the sensor board
- For bus sensors via bus interface with a corresponding software variable

Application notice for humidity sensors

Refrain from touching the sensitive humidity sensor element. Touching the sensitive surface will void guarantee.

When exposed to harsh environmental conditions such as high ambient temperature and/or high levels of humidity, or presence of aggressive gases (i.e. chlorine, ozone, ammonia), the sensor element may be affected and readings may be outside the specified accuracy. Replacement of deteriorated humidity sensors due to harsh environmental conditions is not covered by the general guarantee.

The sensor shows best performance when operated within recommended normal temperature range of 5...60°C and humidity range of 20...80% r.H. Long-term exposure to conditions outside normal range, especially at high humidity, may temporarily offset the humidity signal (e.g. +3% r.H. after 60h kept at >80% r.H.). After returning into the normal temperature and humidity range the sensor will slowly come back to calibration state by itself.

Scope of delivery

Scope of delivery	Description	Type
	Mounting flange for duct sensor 19.5 mm, up to max. 120°C [248°F], Plastic	A-22D-A35

Accessories

Optional accessories	Description	Type
	Replacement filter, wire mesh, Stainless steel	A-22D-A06
	Connection adapter, M20x1.5, for cable 1x6 mm, Multipack 10 pcs.	A-22G-A01.1

Wiring diagram

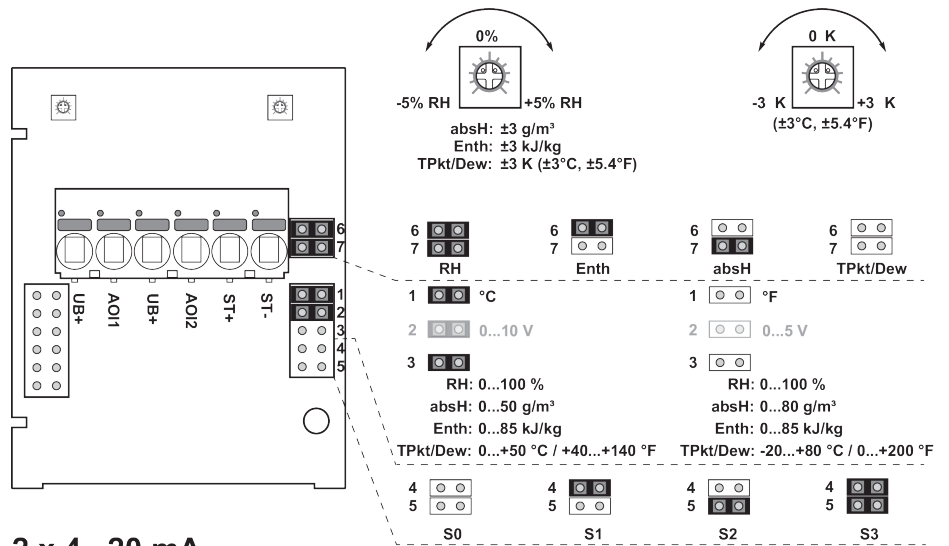

2 x 4...20 mA

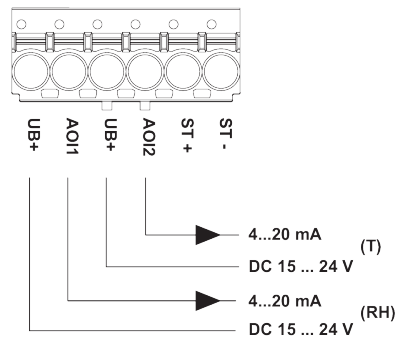

rH Relative humidity
 absH Absolute humidity
 Enth Enthalpy
 TPkt/Dew Dew point
 (Measurement value available on Output AOI1)

Connectors ST+ / ST- are only used for sensor types which additionally have a passive resistance sensor element for temperature measurement.
 Correct temperature values are only available, when the humidity output AOI1 and both inputs UB + are connected.
 The adjustment of the measuring ranges is made by changing the bonding jumpers.
 The output value in the new measuring range is available after 2 seconds.

Setting	range [°C]	range [°F]	Factory setting
S0	-40...60	-40...160	
S1	0...50	40...140	
S2	-15...35	0...100	
S3	-20...80	0...200	✓

Dimensions

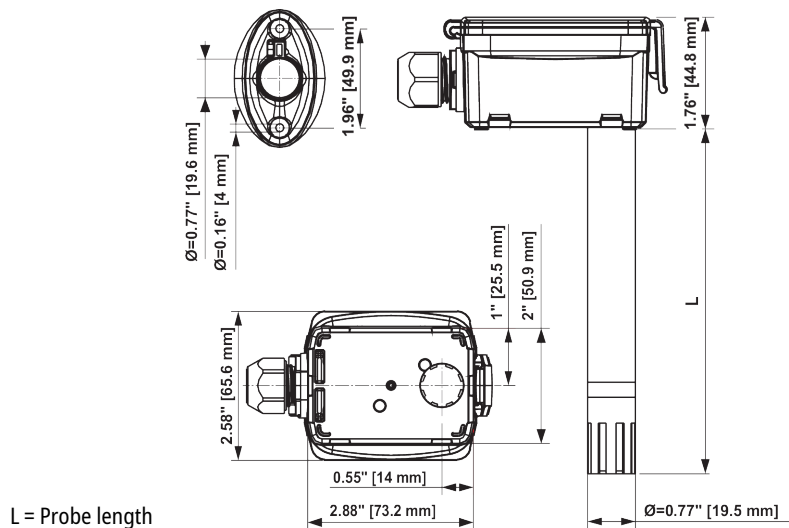

Type	Probe length	Weight
22DTH-13M	140 mm	0.14 kg
22DTH-13Q	270 mm	0.20 kg