

Duct sensor Humidity / Temperature

For measuring the relative or absolute humidity and temperature in duct applications. Instead of the humidity signal, the enthalpy or the dewpoint can be selected as an output signal. With Modbus RTU communication and integrated 0...10 V outputs. Nema 4X / IP65 rated enclosure.

Type Overview

Type	Communication	Output signal active temperature	Output signal active humidity	Probe length
22DTH-15M	Modbus RTU	0...5 V, 0...10 V	0...5 V, 0...10 V	140 mm
22DTH-15Q	Modbus RTU	0...5 V, 0...10 V	0...5 V, 0...10 V	270 mm

Technical Data

Electrical data	Nominal voltage	AC/DC 24 V
	Nominal voltage range	AC 19...29 V / DC 15...35 V
	Power consumption AC	1.8 VA
	Power consumption DC	0.7 W
	Electrical connection	Pluggable spring loaded terminal block max. 2.5 mm ²
	Cable entry	Cable gland with strain relief 2 x Ø6 mm
Functional data	Sensor Technology	Polymer capacitive sensor with stainless steel wire mesh filter
	Communicative control	Modbus RTU
	Voltage output	2x , min. load 10 kΩ
	Output signal active note	Output 0...5/10 V with Jumper adjustable
	Application	Air
Measuring data	Measuring values	Relative humidity Absolute humidity Dew point Enthalpies Temperature
	Measuring range humidity	Adjustable via Modbus Default setting: 0...100% r.H.
	Measuring range temperature	Adjustable via Modbus Default setting: -20...80°C [-5...175°F] Attention: max. measuring temperature is restricted by max. fluid temperature (see Safety data)
	Measuring range absolute humidity	Adjustable via Modbus Default setting: 0...80 g/m ³
	Measuring range enthalpy	Adjustable via Modbus Default setting: 0...85 kJ/kg
	Measuring range dew point	Adjustable via Modbus Default setting: -20...80°C [-5...175°F]
	Accuracy humidity	Typical ±2% between 10...90% RH @ 21°C
	Accuracy temperature active	±0.5°C @ 21°C [±0.9°F @ 70°F]
	Long-term stability	±0.3% RH p.a. @ 21°C @ 50% RH ±0.05°C p.a. @ 21°C [±0.09°F p.a. @ 70°F]

Time constant τ (63%) in air duct	Relative humidity: typical 10 s @ 3 m/s Temperature: typical 125 s @ 3 m/s
--	---

Materials	Cable gland	PA6, black
	Housing	Cover: Lexan, orange Bottom: Lexan, orange Seal: 0467 NBR70, black UV resistant
Safety data	Ambient humidity	Max. 95% r.H., non-condensing
	Fluid humidity	Short-term condensation permitted
	Ambient temperature	-35...50°C [-30...120°F]
	Fluid temperature	-40...80°C [-40...175°F]
	Operating condition air flow	max. 12 m/s
	Protection class IEC/EN	III Safety Extra-Low Voltage (SELV)
	Protection class UL	UL Class 2 Supply
	EU Conformity	CE Marking
	Certification IEC/EN	IEC/EN 60730-1
	Certification UL	cULus acc. to UL60730-1A/-2-9/-2-13, CAN/CSA E60730-1:02/-2-9
	Degree of protection IEC/EN	IP65
	Degree of protection NEMA/UL	NEMA 4X
Quality Standard	ISO 9001	

Safety notes

This device has been designed for use in stationary heating, ventilation and air-conditioning systems and must not be used outside the specified field of application. Unauthorised modifications are prohibited. The product must not be used in relation with any equipment that in case of a failure may threaten humans, animals or assets.

Ensure all power is disconnected before installing. Do not connect to live/operating equipment.

Only authorised specialists may carry out installation. All applicable legal or institutional installation regulations must be complied during installation.

The device contains electrical and electronic components and must not be disposed of as household refuse. All locally valid regulations and requirements must be observed.

Remarks

General remarks concerning sensors Sensing devices with a transducer should always be operated in the middle of the measuring range to avoid deviations at the measuring end points. The ambient temperature of transducer electronics should be kept constant. The transducers must be operated at a constant supply voltage (± 0.2 V). When switching the supply voltage on/off, onsite power surges must be avoided.

Build-up of Self-Heating by Electrical Dissipative Power Temperature sensors with electronic components always have a dissipative power which affects the temperature measurement of the ambient air. The dissipation in active temperature sensors shows a linear increase with rising operating voltage. The dissipative power should be taken into account when measuring temperature. In case of a fixed operating voltage (± 0.2 V) this is normally done by adding or reducing a constant offset value. As Belimo transducers work with a variable operating voltage, only one operating voltage can be taken into consideration, for reasons of production engineering. Transducers 0...10 V / 4...20 mA have a standard setting at an operating voltage of DC 24 V. That means, that at this voltage, the expected measuring error of the output signal will be the least. For other operating voltages, the offset error will be increased by a changing power loss of the sensor electronics.

If a readjustment directly at the active sensor should be necessary during later operation, this can be done with the following adjustment methods.

- For sensors with NFC or dongle by the corresponding Belimo app
- For sensors with a trimming potentiometer on the sensor board
- For bus sensors via bus interface with a corresponding software variable

Application notice for humidity sensors

Refrain from touching the sensitive humidity sensor element. Touching the sensitive surface will void guarantee.

When exposed to harsh environmental conditions such as high ambient temperature and/or high levels of humidity, or presence of aggressive gases (i.e. chlorine, ozone, ammonia), the sensor element may be affected and readings may be outside the specified accuracy. Replacement of deteriorated humidity sensors due to harsh environmental conditions is not covered by the general guarantee.

The sensor shows best performance when operated within recommended normal temperature range of 5...60°C and humidity range of 20...80% r.H. Long-term exposure to conditions outside normal range, especially at high humidity, may temporarily offset the humidity signal (e.g. +3% r.H. after 60h kept at >80% r.H.). After returning into the normal temperature and humidity range the sensor will slowly come back to calibration state by itself.

Scope of delivery

Scope of delivery	Description	Type
	Mounting flange for duct sensor 19.5 mm, up to max. 120°C [248°F], Plastic	A-22D-A35
	Cable Gland with strain relief Ø6...8 mm	

Accessories

Optional accessories	Description	Type
	Replacement filter, wire mesh, Stainless steel	A-22D-A06
	Mounting plate L housing	A-22D-A10
	Connection adapter, M20x1.5, for cable 1x6 mm, Multipack 10 pcs.	A-22G-A01.1
	Connection adapter, M20, for cable 2 x 6 mm, Multipack 10 pcs.	A-22G-A02.1

Wiring diagram

Notes Supply from isolating transformer.



The wiring of Modbus RTU (RS485) is to be carried out in accordance with applicable regulations (www.modbus.org). The device has switchable resistors for bus termination.

Modbus-GND: Supply and communication are not galvanically isolated. Connect earth signal of the devices with one another.

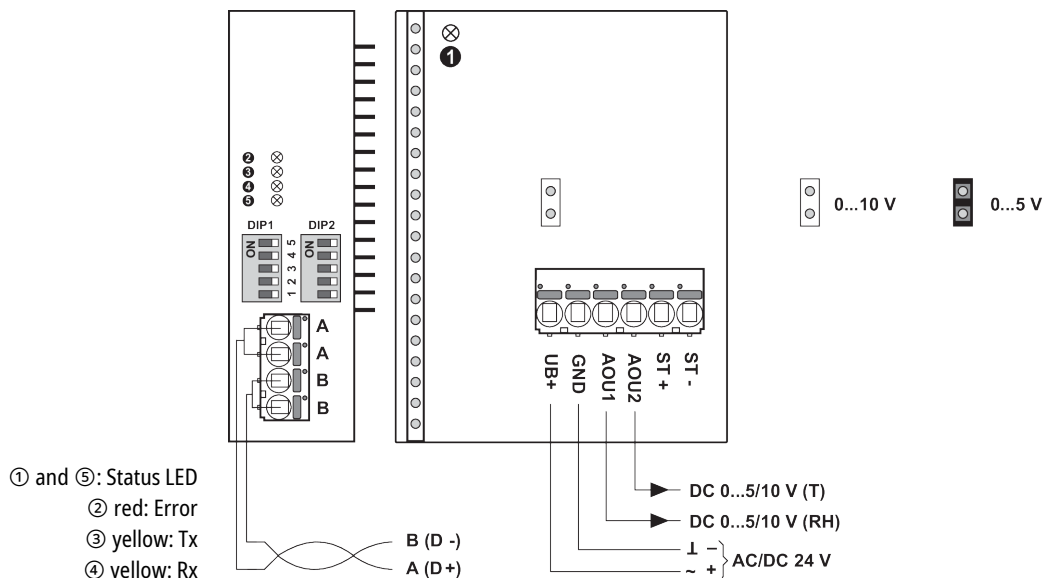

Connectors ST+ / ST- are only used for sensor types which additionally have a passive resistance sensor element for temperature measurement.

The adjustment of the measuring ranges is made by changing the bonding jumpers.

The output value in the new measuring range is available after 2 seconds.

Detailed documentation

The separate document Sensor Modbus-Register informs about Modbus register, addressing, parity and bus termination (DIP1: address, DIP2: baud rate, parity, bus termination)

Wiring RS485 Modbus RTU

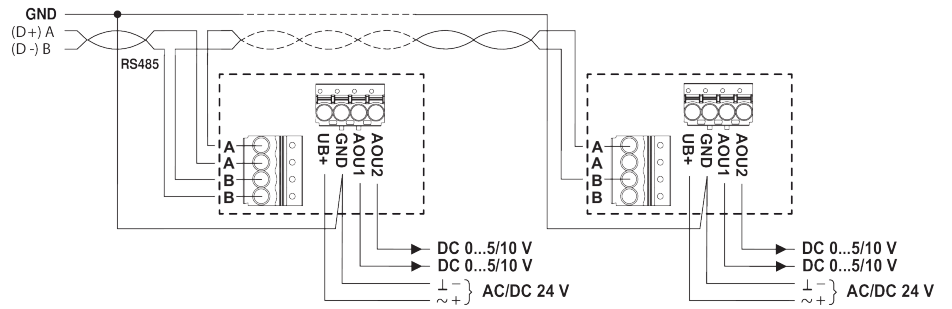

Dimensions

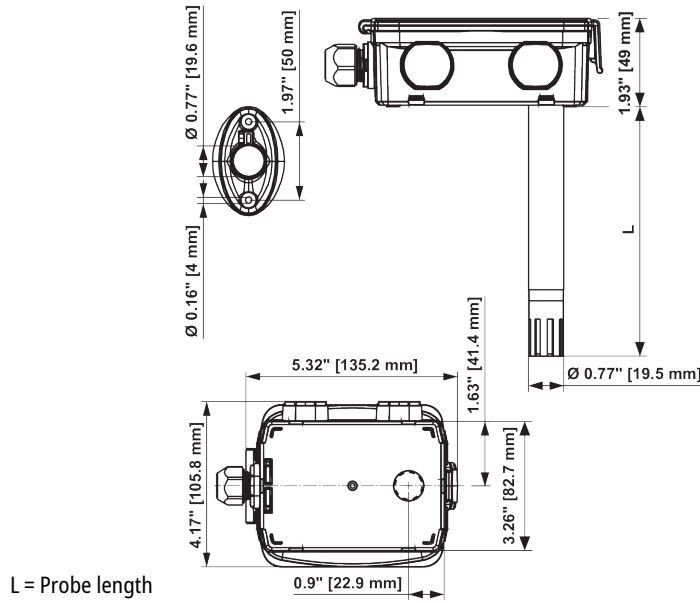

L = Probe length

Type	Probe length	Weight
22DTH-15M	140 mm	0.26 kg
22DTH-15Q	270 mm	0.30 kg