

**Condensation Switch**

For detection of condensation on chilled surfaces (e.g. chilled beams). With signal LED and relay contact for connection to controller and display systems or for series connection with the cooling valve to interrupt the cold water flow directly when condensation begins. NEMA 4X / IP65 rated enclosure.

**Type Overview**

Type	Output signal condensation detector switch	Additional features	Cable length
22HH-100S-6	Changeover	External sensor	7 m
22HH-100S-7	Changeover	External sensor	12 m

**Technical Data**

<b>Electrical data</b>	Nominal voltage	AC/DC 24 V
	Nominal voltage range	AC 21.6...26.4 V / DC 13.5...26.4 V
	Power consumption AC	1.6 VA
	Power consumption DC	0.8 W
	Electrical connection	Removable spring loaded terminal block max. 2.5 mm <sup>2</sup>
	Cable entry	Cable gland with strain relief Ø6...8 mm
<b>Functional data</b>	Output signal switch note	changeover contact, isolated max. switching current 1 A @ 24 V min. switching current 5 mA @ 10 V
	Display	LED, Green - power supply OK Red - dew permeation
	Application	Water
<b>Measuring data</b>	Measuring values	Condensation
<b>Materials</b>	Cable gland	PA6, black
	Housing	Cover: Lexan, orange Bottom: Lexan, orange Seal: 0467 NBR70, black UV resistant
<b>Safety data</b>	Ambient humidity	Max. 95% r.H., non-condensing
	Ambient temperature	-20...50°C [-5...120°F]
	Fluid temperature	-20...60°C [-5...140°F]
	Protection class IEC/EN	III Safety Extra-Low Voltage (SELV)
	Protection class UL	UL Class 2 Supply
	EU Conformity	CE Marking
	Certification IEC/EN	IEC/EN 60730-1
	Certification UL	cULus acc. to UL60730-1A/-2-9/-2-13, CAN/CSA E60730-1:02/-2-9
	Degree of protection IEC/EN	IP65
	Degree of protection NEMA/UL	NEMA 4X
Quality Standard	ISO 9001	

## Safety notes



This device has been designed for use in stationary heating, ventilation and air-conditioning systems and must not be used outside the specified field of application. Unauthorised modifications are prohibited. The product must not be used in relation with any equipment that in case of a failure may threaten humans, animals or assets.

Ensure all power is disconnected before installing. Do not connect to live/operating equipment.

Only authorised specialists may carry out installation. All applicable legal or institutional installation regulations must be complied during installation.

The device contains electrical and electronic components and must not be disposed of as household refuse. All locally valid regulations and requirements must be observed.

## Remarks

**General remarks concerning sensors** Sensing devices with a transducer should always be operated in the middle of the measuring range to avoid deviations at the measuring end points. The ambient temperature of transducer electronics should be kept constant. The transducers must be operated at a constant supply voltage ( $\pm 0.2$  V). When switching the supply voltage on/off, onsite power surges must be avoided.

## Scope of delivery

Scope of delivery	Description	Type
	Mounting plate S housing	A-22D-A09
	Syringe with thermal paste	A-22P-A44
	Screws	
	Dowel	
	Cable tie	

## Accessories

Optional accessories	Description	Type
	Connection adapter, M20x1.5, for cable 1x6 mm, Multipack 10 pcs.	A-22G-A01.1

Wiring diagram

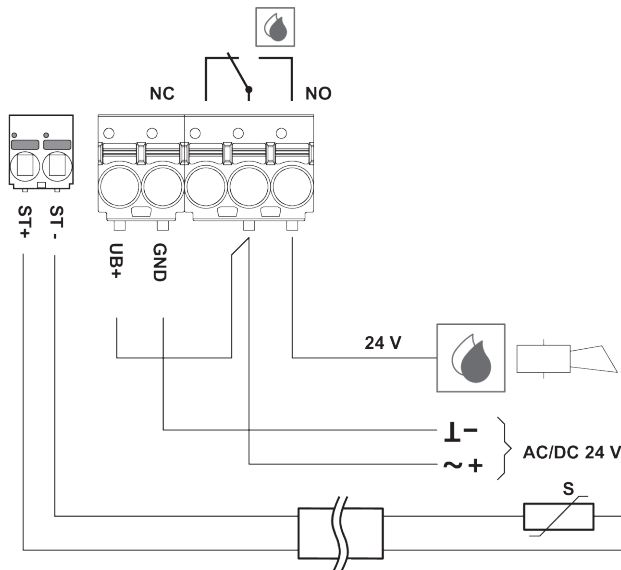
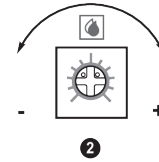
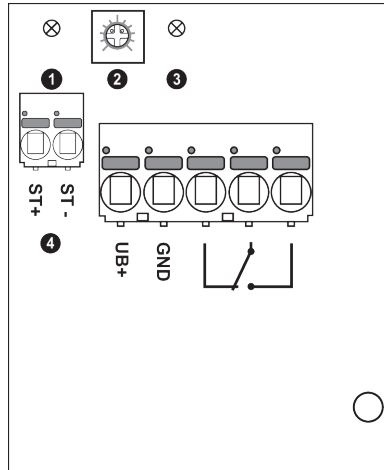

- ① LED red: dew permeation
- ② Sensitivity adjustment  
- less sensible  
+ more sensible
- ③ LED green: power supply OK
- ④ For external condensation sensor

Dimensions

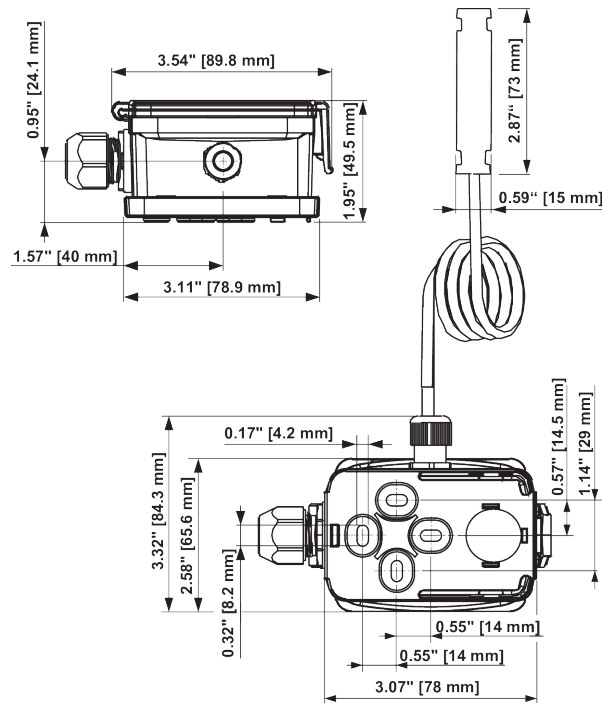

Type	Weight
22HH-100S-6	0.28 kg
22HH-100S-7	0.30 kg