

Three-way Mixing Globe Valves

USE

3F.. series valves are used to control fluids belonging to the group showed in the table in accordance to article 13 of 2014/68/UE (PED) directive, in air-conditioning, thermoventilation and heating plants and in industrial processes; therefore, they cannot be used as safety valves.

MANUFACTURING CHARACTERISTICS

They consist in a 3-way valve body to be assembled on electrical bidirectional actuator.

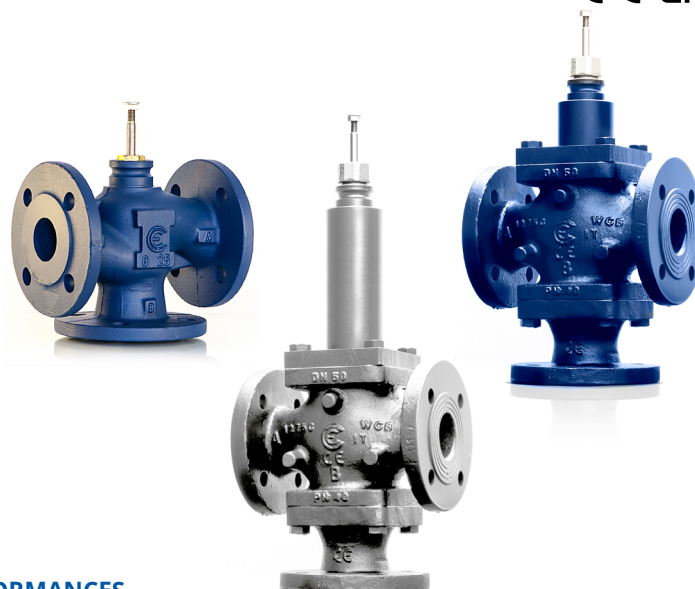

MOTORIZED VALVES TECHNICAL CHARACTERISTICS AND PERFORMANCES

TECHNICAL DATA	3FGB DN 25÷150	3FSA DN 25÷80	3FSAS DN 25÷80	3FAA DN 25÷125	3FAAP DN 25÷125	3FAAT DN 25÷125
Construction	PN16	PN25	PN25 ⁽³⁾	PN40	PN40 ⁽⁶⁾	PN40 ⁽⁶⁾
Body	cast iron	spheroidal cast iron	spheroidal cast iron	steel	steel	steel
Seat	cast iron	stainless steel	stainless steel	stainless steel	stainless steel	stainless steel
Plug	brass (DN25÷100) bronze (DN125÷150)	stainless steel	stainless steel	stainless steel	stainless steel	stainless steel
Stem (D 9mm)	stainless steel	stainless steel	stainless steel	stainless steel	stainless steel	stainless steel
Control characteristic	direct way = equal perc. Angle way = linear	direct way = equal perc. (DN25÷65) linear (DN80) angle way = linear	direct way = equal perc. (DN25÷65) linear (DN80) angle way = linear	linear	linear	linear
Stem packing	EPDM O-Ring ⁽⁴⁾	Teflon V-ring	stainless steel bellows	Teflon V-ring	(2)	(2)
Max. fluid temp. °C	150	230	300	230	350	230
Min. fluid temp. °C	-10 ⁽¹⁾	-10 ⁽¹⁾	-10 ⁽¹⁾	-10 ⁽¹⁾	-10 ⁽¹⁾	-20 ⁽¹⁾
Storage temp.	-20T60°C					
Fluid ⁽⁵⁾	Group 2	Group 2	Group 1	Group 2	Group 1	Group 1
Connections	Flanged PN16	Flanged PN25	Flanged PN25	Flanged PN40	Flanged PN40	Flanged PN40
Max. Kvs leakage % ⁽⁷⁾	direct way 0,03 angle way 2	0,02	0,02	0,02	0,02	0,02

(1) For applications with possible ice formation on stem and gasket, see 248 accessory.

(2) Graphite packing for high temperatures; forced lubrication on extended neck. Teflon packing for low temperatures, see (4).

(3) Due to the bellows presence, the max applicable pressure must not be higher than 5 bar.

(4) Double O-ring and graphite teflon scraper ring.

(5) Group 1: water, overheated water, steam, diathermic oil. For different fluids belonging to group 1, please contact our Sales Support.
Group 2: water, overheated water, glycole added water (50% max.) steam. For different fluids belonging to group 2, please contact our Sales Support.

(6) PN25 only for 3FAA125P and 3FAA125T.

(7) Leakage is measured according to the EN1349 standard.

The performances stated in this sheet can be modified without any prior notice.

INSTALLATION

HYDRAULIC CONNECTIONS

Respect the fluid direction as indicated in Fig. 1 and 2. In particular, we specify that the valves must be mounted as mixing valves with inlet in A and in B and outlet AB.

VALVE MOUNTING

Before mounting the valve, make sure pipes are clean, free from welding slags. The pipes must be perfectly aligned with the valve body and not subjected to vibrations. For installations on plants with high temperature fluids (steam, overheated water, diathermic oil) use expansion joints to avoid the dilatation of pipes to stress the valve body.

Install the valves with the actuator in vertical position for fluid temperature up to 120°C, with higher temperatures they must be mounted horizontally.

NOTE: Following the hydraulic installation it is necessary to check the tight of the stem packing placed on the bonnet, both in cases of low and high temperatures. The valves require periodic maintenance.

Avoid the valve installation in plants, which are considered aggressive and/or corrosive for valve materials.

Please contact our Sales Support in order to determine which potentially aggressive or polluting substances can be used.

We disclaim all responsibility in case of valve failure due to external fortuitous events (fire, earthquakes etc.).

NOTE: The actuator can be rotated with respect to the valve body by blocking the ring nut; after such operation re-tighten the ring nut.

Attention: The stem of 3FSA.S bellows seal valves must never rotate with respect to the valve body it is connected to through the bellows.

ACTUATORS TECHNICAL CHARACTERISTICS, WIRING DIAGRAMS AND INSTALLATION

See actuators data sheets and mounting instructions.

MOTORIZED VALVES OPTIONS

A125-3	Flanges with ANSI125 bolt holes (for 3FSA/3FSAS DN50÷65 and 3FGB DN25÷150)
A150-3	Flanges with ANSI 150 bolt holes (for 3FSA/3FSAS DN50÷65 and 3FAA/3FAAP/3FAAT DN50÷125 valves)
A300-3	Flanges with ANSI 300 bolt holes (for 3FSA/3FSAS DN25÷65, 3FAA/3FAAP/3FAAT DN32÷65 and DN100÷125 valves)
3FGBxxPS89	Grooved valves PN16 to which it is possible to add the relating joint not supplied with the product. General dimensions remain the same. Joint and pipe dimensions are shown in the "Dimensions" paragraph.

ACCESSORIES

248	Stem heater for applications on -10°C low temperature fluid with MVH and MVE actuators
GVB40	Thermal insulation for DN40 3FGB40 valves
GVB50	Thermal insulation for DN50 3FGB50
GVB65	Thermal insulation for DN65 3FGB65
GVB80	Thermal insulation for DN80 3FGB80
GVB100	Thermal insulation for DN100 3FGB100
GVB125	Thermal insulation for DN125 3FGB125
GVB150	Thermal insulation for DN150 3FGB150
GVB40PS89	Thermal insulation for DN40 3FGB40PS89
GVB50PS89	Thermal insulation for DN50 3FGB50PS89
GVB65PS89	Thermal insulation for DN65 3FGB65PS89
GVB80PS89	Thermal insulation for DN80 3FGB80PS89
GVB100PS89	Thermal insulation for DN100 3FGB100PS89
GVB125PS89	Thermal insulation for DN125 3FGB125PS89

APPLICATION SCHEMES

Constant flow mixing to the user

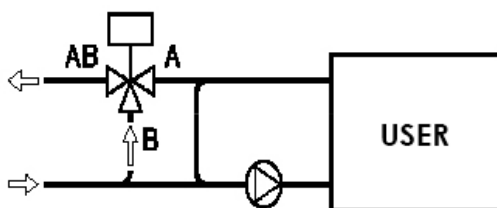

Variable flow mixing to the user

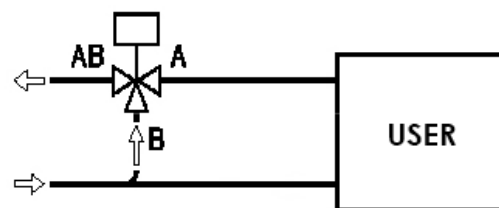

MAX DIFFERENTIAL CLOSE-OFF PRESSURE [kPa]

MODEL	DN	Kvs	MVH		MVHA/C*		MVH3K		MVE.06		MVE.10		MVE.15		MVE.22	
			A-AB	B-AB	A-AB	B-AB	A-AB	B-AB	A-AB	B-AB	A-AB	B-AB	A-AB	B-AB	A-AB	B-AB
3FGB	25R4	4	1600	1600	1100	840	1600	1600	940	700	1590	1270	1600	1600	1600	1600
	25R7	6,3	1600	1600	1100	840	1600	1600	940	700	1590	1270	1600	1600	1600	1600
	25	10	1600	1600	1100	840	1600	1600	940	700	1590	1270	1600	1600	1600	1600
	32 ⁽¹⁾	19	1170	990	590	470	1600	1600	500	390	860	710	1300	1110	1600	1600
	40R19	19	1170	990	590	470	1600	1600	500	390	860	710	1300	1110	1600	1600
	40	25	1170	990	590	470	1600	1600	500	390	860	710	1300	1110	1600	1600
	50	40	730	630	360	300	1600	1440	310	250	530	450	810	710	1200	1069
	65	63	430	370	210	170	960	850	180	150	310	270	480	420	716	633
	80	100	280	240	130	110	620	560	110	90	200	170	310	270	462	418
	100	130	170	150	80	70	390	360	70	60	120	110	190	175	290	267
	125	200	100	100	50	40	240	230	40	40	70	70	120	110	182	171
150	300	70	70	30	30	160	160	30	20	50	50	80	75	124	119	
3FAA 3FAA..P 3FAA..T	25R4	4	2150	1920	1080	770	3000	3000	930	600	1580	1300	2390	2170	3533	3400
	25R7	6,3														
	25	10														
	32	16	1450	1210	730	480	3000	2960	620	380	1060	820	1610	1370	2390	2144
	40	25	940	790	470	310	2090	1940	400	240	690	530	1050	900	1561	1405
	50	40	660	560	330	220	1470	1370	280	170	480	370	740	630	1097	991
	65	63	390	330	190	130	860	810	160	100	280	220	430	370	645	587
	80	100	250	210	120	80	570	530	100	60	180	140	280	240	423	387
	100	140	160	140	70	50	360	340	60	40	110	90	170	150	268	248
125	250	100	80	40	30	230	210	30	20	70	60	110	100	170	159	
3FSA	25R4	4	2500	2500	2150	1250	2500	2500	1850	950	2500	2220	2500	2500	2500	2500
	25R7	6,3	2150	1690	1080	630	2500	2500	930	470	1580	1120	2390	1930	2500	2500
	25	10	2150	1690	1080	630	2500	2500	930	470	1580	1120	2390	1930	2500	2500
	32	19	1450	1140	730	420	2500	2500	620	310	1060	750	1610	1300	2390	2078
	40	25	1040	820	520	300	2310	2080	440	220	760	540	1160	940	1722	1497
	50	40	660	520	330	180	1470	1330	280	130	480	340	740	590	1097	953
	65	63	390	300	190	100	860	780	160	70	280	190	430	340	645	560
	80	100	250	230	120	105	500	500	100	85	180	160	280	220	423	367
3FSA..S	25R4	4	500	500	500	500	500	500	500	500	500	500	500	500	500	500
	25R7	6,3	500	500	500	500	500	500	500	500	500	500	500	500	500	500
	25	10	500	500	500	500	500	500	500	500	500	500	500	500	500	500
	32	19	500	500	500	500	500	500	500	470	500	500	500	500	500	500
	40	25	500	500	500	420	500	500	440	340	500	500	500	500	500	500
	50	40	500	500	330	270	500	500	280	220	480	420	500	500	500	500
	65	63	390	350	190	160	500	500	160	130	280	250	430	400	500	500
	80	100	250	230	120	100	500	500	100	80	180	160	288	260	423	500
3FGBxxPS89	40	25	1170	990	590	470	1600	1600	500	390	860	710	1300	1110	1600	1600
	50	40	730	630	360	300	1600	1440	310	250	530	450	810	710	1200	1069
	65	63	430	370	210	170	960	850	180	150	310	270	480	420	716	633
	80	100	280	240	130	110	620	560	110	90	200	170	310	270	462	418
	100	130	170	150	80	70	390	360	70	60	120	110	190	175	290	267
125	200	100	100	50	40	240	230	40	40	70	70	120	110	182	171	

100kPa = 1bar = 10m_{H₂O}

(1) same dimensions as a DN40 valve

* in case of lack of voltage, with MVH.A direct way is closed, with MVH.C angle way is closed.

Kvs is the flow rate expressed in m³/h of water at a temperature between 5°C and 40°C passing through a valve open at the nominal stroke with 100kPa (1bar) differential pressure.

MAX REGULATION DIFFERENTIAL PRESSURE [kPa]

The max regulation differential pressure, it means the pressure which can be used during the stroke, is conditioned by wear between seat and plug and by the performance guaranteed by the actuator for the evaluated valve. So we recommend not to overcome the differential pressure whose value corresponds to the minimum between the one here following (maximum admitted

value not to cause wear) and the one shown in the previous table (max close-off differential pressure).

3FGB = 200kPa 3FSA/3FSAS = 800kPa 3FAA/3FAAP/3FAAT = 1200kPa

NOTE: The max operating pressures at different temperatures for different PN classes must correspond to the following standards: UNI 1092-2 and UNI 12516-1.

DIMENSIONS [mm]

PS89 models (PN16)

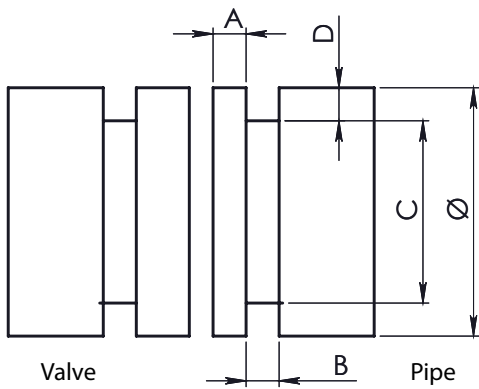

valve DN	grooved joint DN	Ø			A	B	C		D
		external pipe diameter			gasket seat	groove width	groove diameter		groove depth (ref.)
		base	max	min	± 0.76*	± 0.76*	max.	min.	
40	50	60,30	60,90	59,70	15,88	7,95	57,20	56,80	1,6
50	65	76,10	76,90	75,40	15,88	7,95	72,30	71,80	1,98
65	80	88,90	89,80	88,10	15,88	7,95	84,90	84,50	1,98
80	100	114,30	115,40	113,50	15,88	9,53	110,10	109,60	2,11
100	125	139,70	141,10	138,90	15,88	9,53	135,50	135	2,11
125	150	168,30	169,90	167,50	15,88	9,53	164	163,40	2,16

* ± 0,76 for grooved joint DN < 100

± 1,14 for grooved joint DN ≥ 100

3FGB

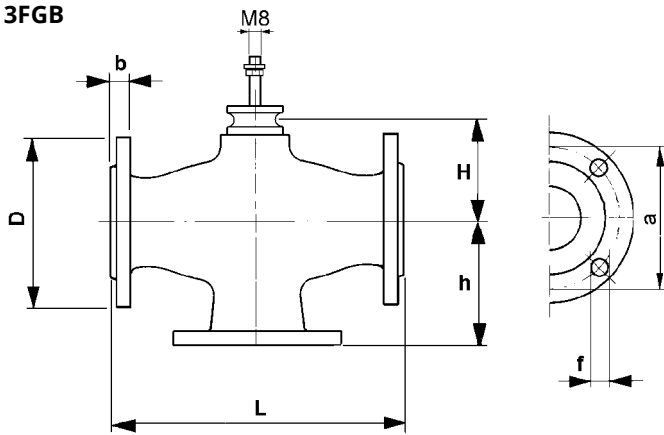

3FSA / 3FAA

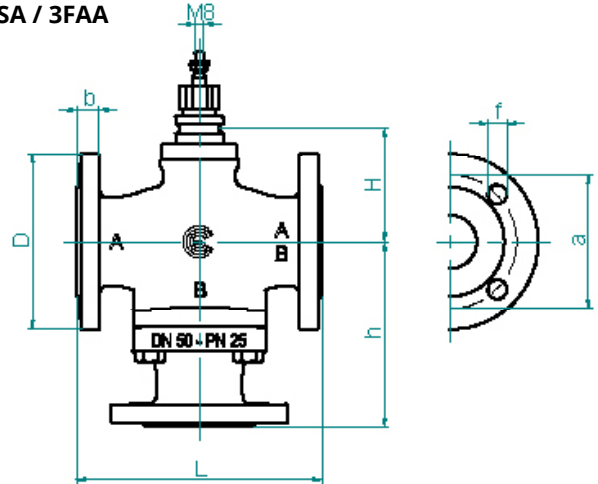

3FSAS / 3FAAP / 3FAAT

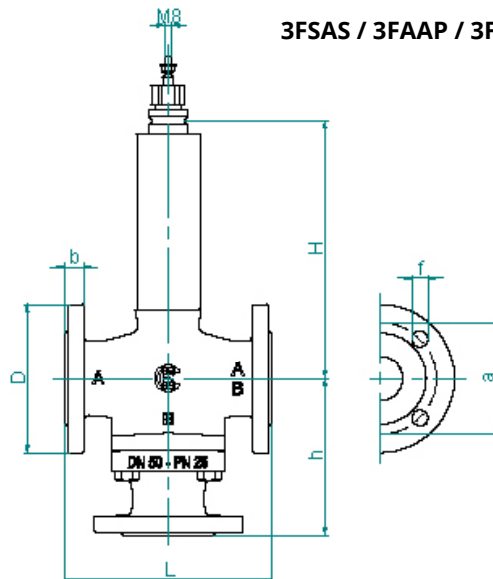

MODEL	DN	L	H	H	D	B	A	F	HOLE n.	WEIGHT [kg]	STROKE [mm]
3FGB (PN 16)	25	160	50	80	115	16	85	14	4	5,2	16,5
	32 ⁽¹⁾	200	64	100	150	18	100	18	4	9,4	25
	40	200	64	100	150	18	110	18	4	9,4	25
	50	230	66	115	165	20	125	18	4	13,4	25
	65	290	84	145	185	20	145	18	4	18,8	25
	80	310	94	155	200	22	160	18	8	23,8	45
	100	350	105	175	220	22	180	18	8	32	45
	125	400	128	200	250	24	210	18	8	45,6	45
	150	480	146	240	285	24	240	22	8	61,2	45
3FSA (PN 25)	25	160	92	137	115	18	85	14	4	8	16,5
	32	180	97	159	1240	20	100	18	4	12	25
	40	200	98	162	150	20	110	18	4	14	25
	50	230	107	171	165	22	125	18	4	18	25
	65	270	117	190	185	24	145	18	8	25	25
	80	310	181	207	200	26	160	18	8	42,8	45
3FAA (PN 40)	25	160	124	140	115	17	85	14	4	12,4	16,5
	32	180	139	157	140	17	100	18	4	18,2	25
	40	200	165	160	150	17	110	18	4	21,6	25
	50	230	168	172	165	19	125	18	4	26	25
	65	270	183	190	185	21	145	18	8	36	25
	80	310	199	207	200	23	160	18	8	47,8	45
	100	350	178	247	235	24	190	22	8	55	45
	125	400	203	282	270	26	220	25	8	78	45
3FSAS (PN 25)	25	160	274	137	115	18	85	14	4	10	16,5
	32	180	279	159	140	20	100	18	4	15	25
	40	200	280	162	150	20	110	18	4	17	25
	50	230	289	171	165	22	125	18	4	21	25
	65	270	299	191	185	24	145	18	8	29	25
	80	310	413	207	200	26	160	18	8	45,6	45
3FAAP 3FAAT (PN 40)	25	160	195	140	115	18	85	14	4	15,7	16,5
	32	180	269	157	140	18	100	18	4	22,3	25
	40	200	277	160	150	18	110	18	4	25	25
	50	230	293	172	165	20	125	18	4	29,7	25
	65	270	308	190	185	22	145	18	8	39,3	25
	80	310	324	207	200	24	160	18	8	50,8	45
	100	350	303	247	235	24	190	22	8	67	45
	125	400	328	282	270	26	220	25	8	98,6	45

(1) same dimensions as a DN40 valve