

STC65+ RS485-EVC

Bidirectional EnOcean gateways with RS485 interface

thermokon[®]
HOME OF SENSOR TECHNOLOGY

Datasheet

Subject to technical alteration
Issue date: 8/16/2022 • A122



» APPLICATION

Bidirectional gateways with serial interface RS485 in IP65 enclosure for connecting on several controller with EnOcean software libraries, (e.g. WAGO[®] or SAIA[®]). For receiving EasySens sensors (e.g. temperature sensors or wireless switches), and sending open programmable telegrams. Intended for connection with a room- or area- controller with 1 gateway per RS485 bus. In comparison with Modbus RTU, the EVC protocol is faster but doesn't support bus access control and bus collisions with more than one bus participant cannot be prevented. Incl. external receiving antenna (2.5 m).

» SECURITY ADVICE – CAUTION

The installation and assembly of electrical equipment should only be performed by authorized personnel.



The product should only be used for the intended application. Unauthorised modifications are prohibited! The product must not be used in relation with any equipment that in case of a failure may threaten, directly or indirectly, human health or life or result in danger to human beings, animals or assets. Ensure all power is disconnected before installing. Do not connect to live/operating equipment.

Please comply with

- Local laws, health & safety regulations, technical standards and regulations
- Condition of the device at the time of installation, to ensure safe installation
- This data sheet and installation manual

» PRODUCT TESTING AND CERTIFICATION



Declaration of conformity

The declaration of conformity of the products can be found on our website <https://www.thermokon.de/>

» NOTES ON DISPOSAL



As a component of a large-scale fixed installation, Thermokon products are intended to be used permanently as part of a building or a structure at a pre-defined and dedicated location, hence the Waste Electrical and Electronic Act (WEEE) is not applicable. However, most of the products may contain valuable materials that should be recycled and not disposed of as domestic waste. Please note the relevant regulations for local disposal.

» TECHNICAL DATA

Network technology	RS485
Communication protocol	EVC RS485 bus load: 1 unit load according to RS485 standard (max. 32 devices)
Radio technology	EnOcean (IEC 14543-3-10), transmission power <10 mW
Frequency	902 MHz, optional 315 MHz
Antenna	external transmit- / receive antenna
Data transmission	bidirectional
Receive- transmit channels	filter-mode: 64 (Rx), gateway-mode: ∞ (Rx) filter-mode: 128 (Tx), gateway-mode: 128 (Tx)
Power supply	15..24 V = (±10%) or 24 V ~ (±10%) SELV
Power consumption	typ. 0,8 W (24 V =) 2 VA (24 V ~)
Enclosure	enclosure USE-M, PC, pure white, cover PC, transparent
Protection	IP65 according to EN 60529
Cable entry	M25, for wire max. Ø=0.28 in., seal insert for fourfold cable entry
Connection electrical	terminal block, max. 16AWG
Ambient condition	-4..+140 °F, max. 70% rH non-condensing
Weight	without antenna 3.88oz.
Delivery content	external transmit- / receive antenna
Notes	up to 15 devices with Smart Acknowledge (SmartACK), magnetic antenna holder required for better radio range

» MOUNTING ADVICES

The module enclosure can be mounted directly onto a DIN top-hat rail using the mounting base or surface-mounted using dowels and screws.

- The antenna should be mounted at metallic objects, e.g. at an air tube behind a false ceiling or on a metal plate (minimum dimensions: 7.1 in. x 7.1 in., material: galvanized sheet steel, see accessories).
- In rooms the antenna should be at least 4 in. away from the ceiling.
- The antenna should be vertically aligned downwards.
- Minimal distance to the wall: 4 in.
- Distance to other transmitters (e.g. GSM/ DECT/ wireless LAN/ EnOcean sender): at least 20 in.
- The antenna cable shall be wired in an electric conduit.
- A crushing of cable shall be absolutely avoided.
- The minimal bend radius of the extension cable is 2 in..
- As for the cable laying the use of an active pull-up device should be avoided, so to avoid any damages on the sheathing respectively on the connectors.

» COMMISSIONING

Radio sensors send time or event controlled telegrams to the receiver. The receiver verifies the incoming telegrams and output them directly via their interface. Each telegram allows a precise allocation and consists of the format: type of the telegram, data, sender-ID 32bit.

In order to assure a correct evaluation of the measuring values by the receiver, it is necessary to have the devices learned by the receiver. This is done automatically by means of a "learn button" at the sensor or manually by input of the 32bit sensor ID and a special "learning procedure" between sender and receiver. The respective details are described in the corresponding software documentation of the receiver.

» LED ERROR CODES

PWR	BUS	RAD	ERR	
■		X	●/■	faulty bus communication
○	●	○	●	faulty dipswitch setting
○	○	●	●	Error radio module

■ LED flashes

● LED permanently ON

○ LED OFF

» **CONNECTION CONFIGURATION - STC65+ RS485-EVC**

Factory default: Address 1, 9600Bd, Parity even, Compatibility mode EIN

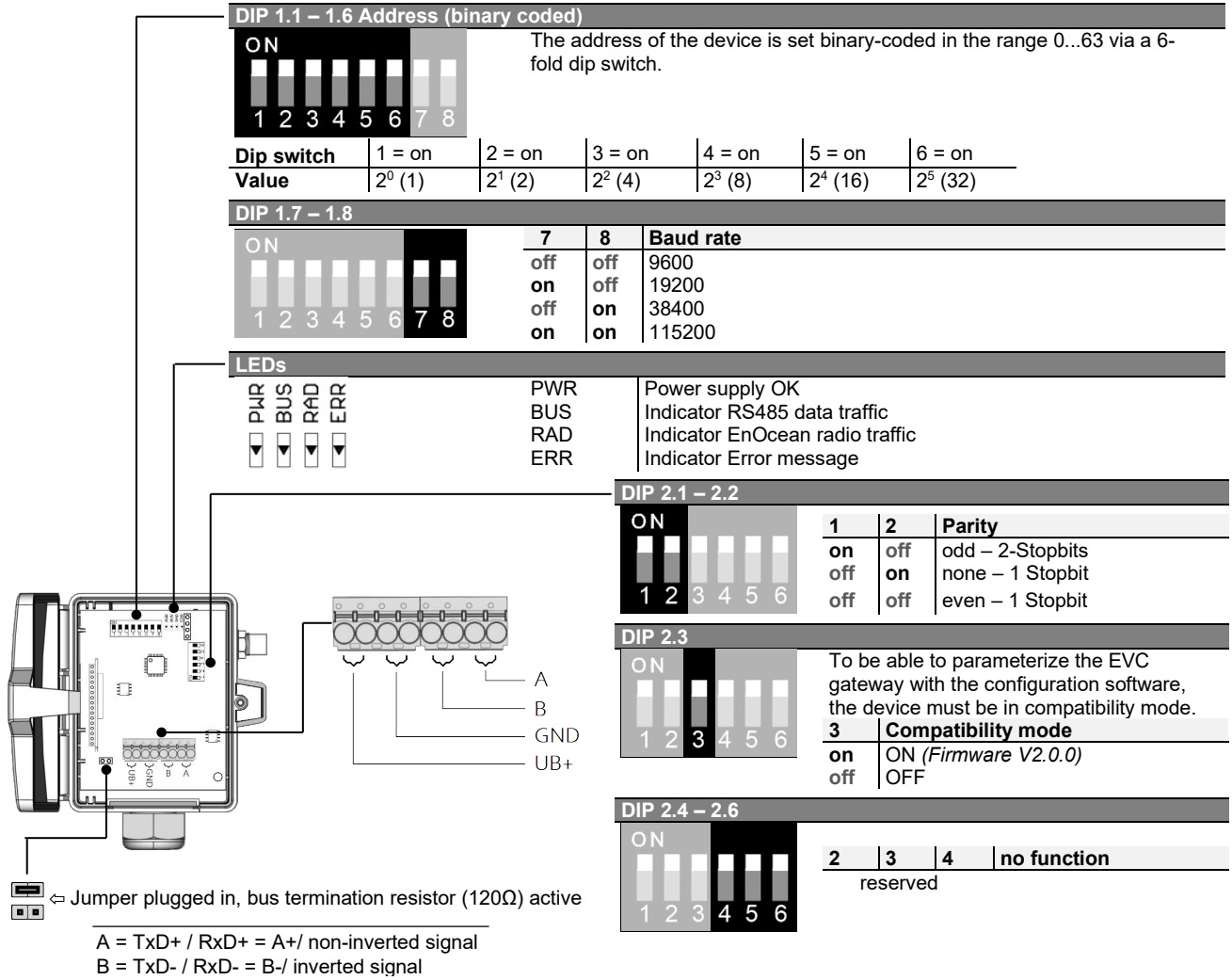

By switching the dipswitch 2.3 the compatibility mode is deactivated/activated. This serves to be able to exchange older models easily. VLD/MSK telegrams, SMACK and various commands are not available. The answers to commands correspond to the firmware version 2.0.0.

Interface description



The configuration software and further information on parameterization of the EVC Gateway can be downloaded from the following link. → [Download *.zip](#)

» **INFORMATION ABOUT EASYSSENS® (RADIO) / ENOCEAN**



EasySens® - EnOcean
 Basic information about EasySens® radio and installation are found on our website.

» **OVERVIEW OF THE RADIO TELEGRAMS**



EEP
 The structure of the data contained in the telegram are found in the EEP (EnOcean equipment profile) list provided by the EnOcean Alliance.

» **INFORMATIONEN ABOUT EASYSSENS® - AIRSCAN**



EasySens® - Airscan Radio Signal strenght measuring software
 Basic information about EasySens® - Airscan and installation are found on our website

» INFORMATION ABOUT SMART ACKNOWLEDGE (SMARTACK)

This bi-directional communication mechanism also allows the building system to send back data to a sensor, i.e. to overwrite SR06LCD's set point. Smart Acknowledge requires that both communication devices do support the Smart Acknowledge mechanism.



Communication must be performed directly with a SmartACK capable receiver, e.g. STC65-FTT LON (SMACK special version) or STC65+ RS485 Modbus/EVC. Repeaters are not supported, they delay in the telegram transmission. Sensor and gateway must communicate directly with each other.

Additional Information of the used EEP's with Smart ACK can be found using the following link:

→ [Download PDF](#)

» DIMENSIONS (IN)

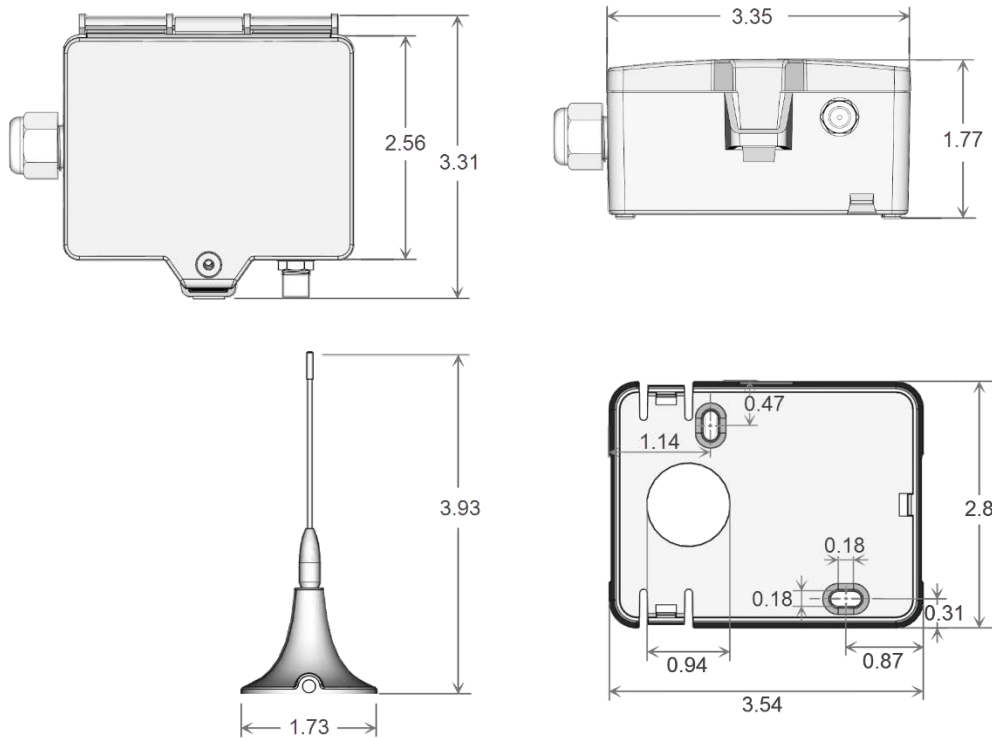

» ACCESSORIES (INCLUDED IN DELIVERY)

Mounting base

Item No. 631228

Mounting kit universal

Item No. 698511

• Cover screw + screw cover • 2 Rawlplugs • 2 Screws (countersunk head) • 2 Screws (rounded head)

» ACCESSORIES (OPTIONAL)

Airscan USB EnOcean Transceiver (902 MHz)

Item No. 566711

Antenna extension 10 m

Item No. 257206

Antenna extension 20 m

Item No. 257213

Antenna holder form L, 180x180 mm

Item No. 255097

Rawl plugs and screws

Item No. 102209