

Model	Description	Supply	Control
AXCU22/W	Electronic controller for 2/4-pipe fan-coil	230 V 50/60 Hz	ON/OFF



APPLICATION AND USE

AXCU models are electronic controllers for 2-4 pipe fan-coils to control on/off valves and manual fan control (3 speed).

TECHNICAL CHARACTERISTICS

Power voltage 230V~ ±10%
 Frequency 50/60 Hz
 Maximum input power 2W max
 Max. admissible current on contacts 0,5A. 230V~
 Insulation class II (IEC 950)
 Protection degree IP30
 Temperature
 - operating T60°C
 - storage -20T85 °C
 Humidity (non-condensing)
 - operating 10÷90%
 - storage 10÷90%
 Housing plastic resin PC+ABS
 Dimensions mm (LxIxh) 120x80x40
 Installation wall-mounted using the backplate as a drilling template

The product complies with EC low voltage (73/23/EEC) and EMC (89/336) directives according to the following regulations:
 EN 60730 Emissions: EN 50081-1 (EN 55022)
 Immunity: EN 50082-1

OPERATION

The operating mode is automatically selected according to the temperature detected by the sensor.

AXCU22/WMB provides the automatic control of fan speed.

INSTALLATION

Open the equipment by a screwdriver, playing on the slots (A, B, C, D) (see fig.1).
 Lean the controller back on the wall for doing the 4 holes to fix it, by the base.
 Locate the 2 terminal boards. (fig. 3).

ADJUSTMENT OF THERMOSTAT OPERATING RANGE (fig. 2)

To limit the thermostat operating range remove the front cover and dislodge the adjustment knob by levering a screwdriver on the grey pin located in the hole on the card, under the knob.
 Then move the grey blocks (A) until the desired differential is obtained. Standard factory adjustment is 5T35 °C.

INPUTS

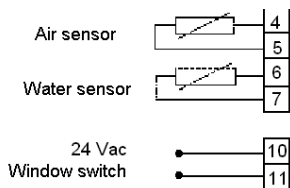

Three analogue inputs are available:

Inputs	Description	Sensor range	Size range
ST1	Room temperature sensor (always built-in). Sensor mounted on the electronic card for wall installations.	-50°C +100°C	-50°C +110°C
ST2	Optional sensor; it inhibits the ST1 operation, if present. It is used for the room temperature adjustment, it is installed on the equipment for ceiling or floor installations.	-50°C +100°C	-50°C +110°C
ST3	Optional sensor; it starts the Hot Start and Too Cool functions, if present. It is used to detect the water temperature and it must always be mounted downstream the water valve.	-50°C +100°C	-50°C +110°C

OUTPUTS

Outputs	Function	Description
FAN	Supply fan control	It starts the ventilation. The fan control slider allows to bring the phase onto three different terminals in order to obtain a manual selection of 3 fan speeds.
OUT1	Valve control	It allows the water flow in the battery.
OUT2	It controls the valve or the electrical resistances	The triac drives the battery of electrical resistances, if present. If not, the triac is managed as second valve of a 4-pipe plant.

OUTPUTS	only 2-PIPE	2-PIPE with electrical resistances	4-pipe
OUT1	Not used	Electrical resistance	Cooling valve
OUT2	Heating/cooling valve	Heating/cooling valve	Heating valve

Setting can be changed on field according to Dip Switches Configuration Table (see TAB. 1).

SENSORS

ST1: sensor for room air temperature (always built-in)

Sensor included in the card, enabled when DIP1=On
Sensor range: -10°C to 70°C

SENSOR INPUTS

ST2: Input for room temperature (remote*) sensor

enabled when DIP1=Off

This is the remote sensor which is used for the room temperature control. See diagram (Fig. 4) for wiring connections. Sensor range: -10°C to 70°C

ST3: Input for water-cooled heat-exchanger temperature sensor (remote*)

This sensor, which should be installed downstream the water valve, is used for water temperature control. It is involved in qualification and control functions. See diagram (Fig. 4) for wiring connections.

This input can be used for "WINDOW CONTACT", with ENERGY SAVING functions: when the contact is closed the controller changes over to stand-by with the antifreeze function enabled. Sensor range: -10°C to 70°C

If the ST3 sensor is present, the heating controller, during heat request, controls the heating valve and for 3 minutes stops the fan speed (Hot-start function).

The ST3 sensor is not necessary if the electrical resistance operation is chosen.

Similarly, it happens if the controller is in cooling logic, the fan is inhibited until the water temperature is not cool enough (Too-cool feature).

* not included, SNTC-L model with ABS cap or SNTC-SL model with AISI 304 cap.

NOTE: ALWAYS USE THE SNTC-SL SENSOR FOR 2-PIPE APPLICATIONS.

CONNECTIONS

The equipment is fitted with screw terminal strips for the connection of leads having a maximum cross-section of 1.5 mm² (as regards power contacts, use one lead for each terminal). Electrical connections must always be performed with the device off. Make sure that the available power voltage conforms to the one required by the equipment. Use only the supplied screws. Do not mount the instrument on metal surfaces. Do not poke anything into the slots on the device (be it on or off).

The sensor requires no installation polarity and can be extended using an ordinary 1 mm² min section bipolar cable (mind that extending the sensor may affect sensor behaviour due to electromagnetic compatibility and that the allowed max. length of the cable is 50 m. - measure error <1°C).

Use only the supplied sensors. Grant a minimum distance of 8 mm between the devices components/fittings and the accessible parts (cables, sensors, etc.).

PRECAUTIONS

For safety reasons the device must be operated following manufacturer instructions. Notably, because of the hazards entailed, under ordinary use conditions live and/or heating parts must not be accessed. The device must be protected from water and dust.

Any use other than the allowed ones is forbidden. The relay contacts supplied are functional-type and are consequently liable to faults: any protection equipment as regards obvious safety needs, foreseen by the applicable regulations or suggested by common sense must be carried out outside the device.

AXC22/W DIP SWITCHES CONFIGURATION

DIP number	Description	ON	OFF
1	Electrical heater	Yes	No
2	2-pipe or 4-pipe	4-pipe	2-pipe
3	Electrical heater control	Control	Integrated
	Hot Start time	Hot Start=0 (not delayed)	Hot Start (delayed time)
4	Dead zone value Hysteresis value	5° K 2° K	2° K 1° K
5	Fan status in cooling	Thermostat demand	Always ON
6	Air sensor used	Local	Remote

TAB. 1

LED

Led L1: ON /Economy (yellow)

- ON: controller on
- Slow flashing: controller on and Economy function enabled (only for models 4200-1819)
- OFF: controller off

Led L2: cooling (green)

- ON: thermostat under demand with fan, valve and/or heater element enabled.
- Slow flashing: thermostat under cooling demand with valve and fan disabled because water temperature sensor has not given consent.
- Fast flashing: thermostat under cooling demand with valve enabled and fan disabled because water temperature sensor has not given consent.
- OFF: all other cases

Led L3: heating (red)

- ON: thermostat under heating demand, with fan, valve and/or heater enabled.
- Slow flashing: thermostat under heating demand, with valve and fan disabled because the water temperature sensor has not given consent.
- Fast flashing: thermostat under heating demand with valve enabled and fan disabled because the water temperature sensor has not given consent.
- OFF: all other cases

All leds will flash for three seconds when the controller is powered. All leds will continue flashing when a temperature sensor is damaged or when the WINDOW CONTACT function is enabled.

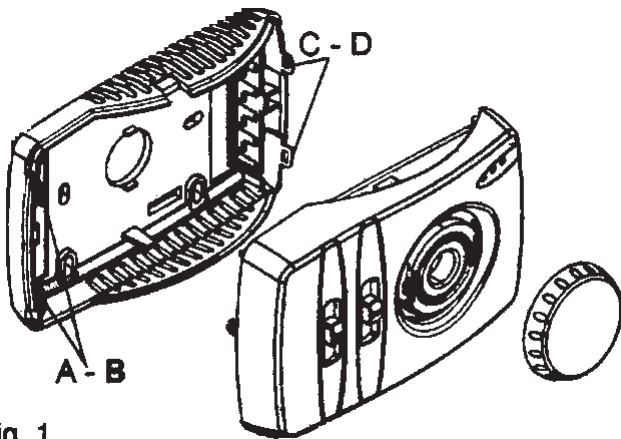

Fig. 1

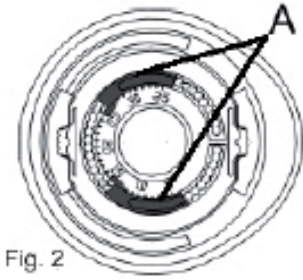

Fig. 2

ELECTRICAL WIRING

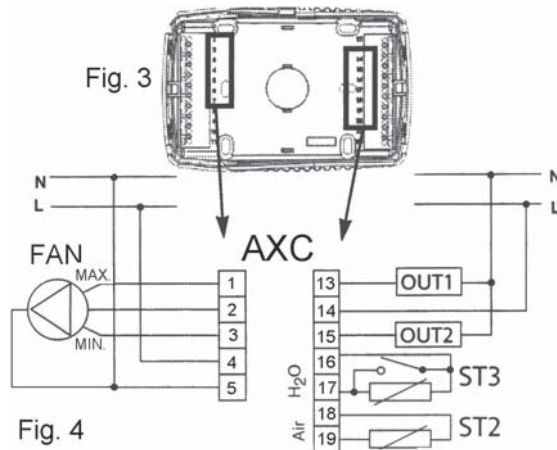
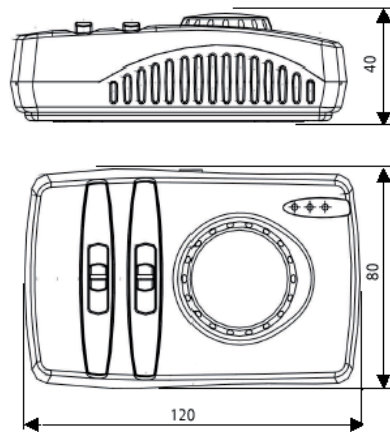

Fig. 4

OVERALL DIMENSIONS (mm)



The performances stated in this sheet can be modified without any prior notice due to design improvements