

### INTRODUCTION

The CO<sub>2</sub> transmitter uses Infrared Technology to monitor CO<sub>2</sub> levels and outputs a linear 4-20 mA or 0-5/0-10 Vdc signal. Options include a control relay and a resistive temperature sensor. Features include a back-lit LCD and a user menu for easy installation.

### BEFORE INSTALLATION

Read these instructions carefully before installing and commissioning the transmitter. Failure to follow these instructions may result in product damage. Do not use in an explosive or hazardous environment, with combustible or flammable gases, as a safety or emergency stop device or in any other application where failure of the product could result in personal injury. **Take electrostatic discharge precautions**

**during installation and do not exceed the device ratings.**

### MOUNTING

Mount the sensor in an easily accessible location in a straight section of duct at least five feet from corners or other items that may cause disturbances in the air flow. Avoid areas where the detector is exposed to vibrations or rapid temperature changes.

The principal of operation is based on the Venturi effect of the probe that extends into the HVAC duct. Air flowing through the duct is forced into the vent holes on one side of the probe, into the enclosure, over the CO<sub>2</sub> sensor and then the air is drawn back out of the enclosure via the vent holes on the opposite side of the probe.

Drill or punch a 7/8" or 1" hole in the duct at the preferred location and insert the probe into the hole to mark the enclosure mounting holes. Remove the unit and drill the two mounting holes. Clean all drilled holes of debris before mounting the device. Mount the enclosure to the duct with two sheet metal screws such that the duct air flow is parallel with the vent holes in the probe (i.e.: air flows directly into the probe holes). To prevent air leaks, ensure the gasket is compressed around the probe between the device enclosure and the air duct.

The enclosure has a hinged cover with a latch. Open the cover by pulling slightly on the latch on the bottom of the enclosure, at the same time pulling on the cover, as illustrated in Figure 2.

A 1/2" NPT threaded connection hole is provided in the left side of the enclosure. Screw the EMT connector or cable gland connector in until tight. See Figure 3. It is recommended that weatherproof conduit or cable gland fittings be used. The F style enclosure includes a 1/2" NPT to M16 thread adapter and cable gland fitting.

Make wiring connections as per the "Wiring" illustrations on Page 2.

Swing door closed until securely latched. For added security, 2 screws are provided that may be installed in the integrated screw tabs. See Figure 4.

Figure 1

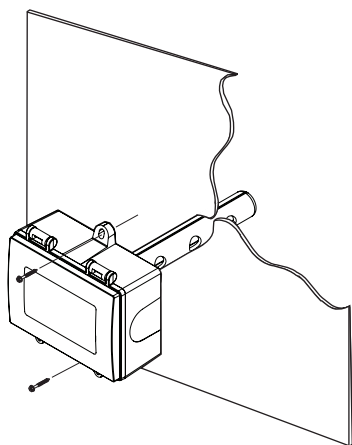

Figure 2

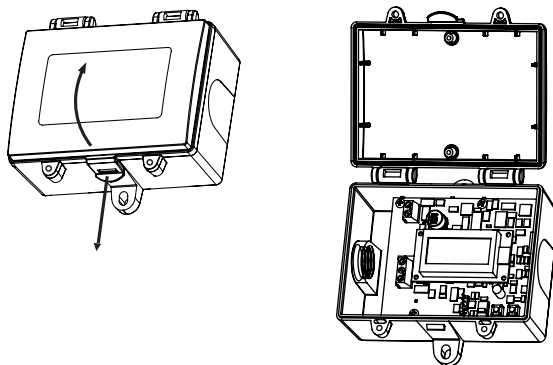

Figure 3

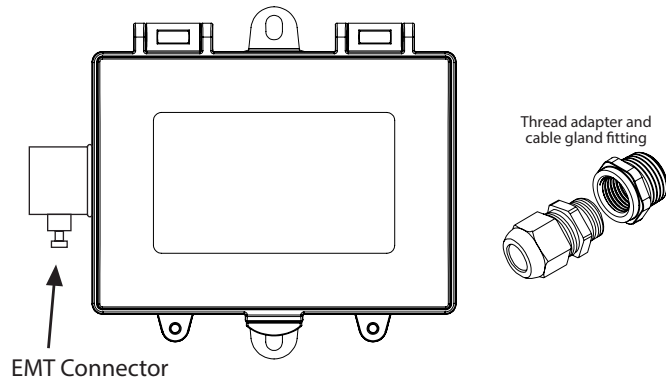
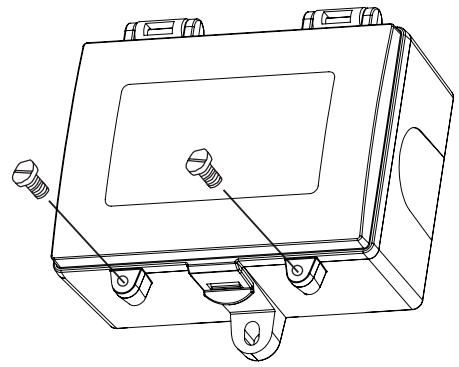

Figure 4



## WIRING

- Deactivate the 24 Vac/dc power supply until all connections are made to the device to prevent electrical shock or equipment damage. Follow proper electrostatic discharge (ESD) handling procedures when installing the device or equipment damage may occur.
- Use 22 AWG shielded wiring for all connections and do not locate the device wires in the same conduit with wiring used to supply inductive loads such as motors. Make all connections in accordance with national and local codes.
- Connect the plus dc or the ac voltage hot side to the POWER terminal.
- The supply common is connected to the COMMON terminal.
- The device is reverse voltage protected and will not operate if connected backwards. It has a half-wave power supply so the supply common is the same as the signal common.
- Several devices may be connected to one power supply and the output signals all share the same common. Use caution when grounding the secondary of a transformer or when wiring multiple devices to ensure the ground point is the same on all devices and the controller.
- The analog output is available on the CO2 terminal. This signal is jumper selectable for either voltage or 4-20 mA active output. In voltage mode the output is selectable for either 0-5 or 0-10 Vdc via the menu (the factory default is 0-5 Vdc). The current output operates in the active mode and does not require a loop power supply. This means that the signal current is generated by the transmitter and must not be connected to a powered input or device damage will result.
- Check the controller Analog Input to determine the proper connection before applying power. Both current and voltage signals are referenced to the COMMON terminal. The analog output signal is typically connected directly to the Building Automation System (B.A.S.) and used as a control parameter or for logging purposes.
- An optional signal is the relay output available on the N.O. RELAY terminals. The relay output is completely isolated and has a Normally Open (NO) signal. This signal can be used to directly control an alarm or ventilation fan.
- The two-wire resistive temperature sensor output signal can be ordered with various RTDs and thermistors to suit all control applications and is available on the TEMP and TEMP A terminals.

NOTE: The N.O. RELAY terminal is optional and may or may not be on the device

Figure 5

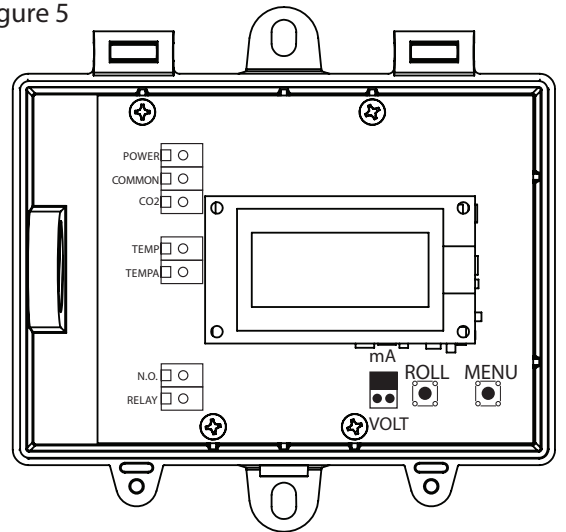
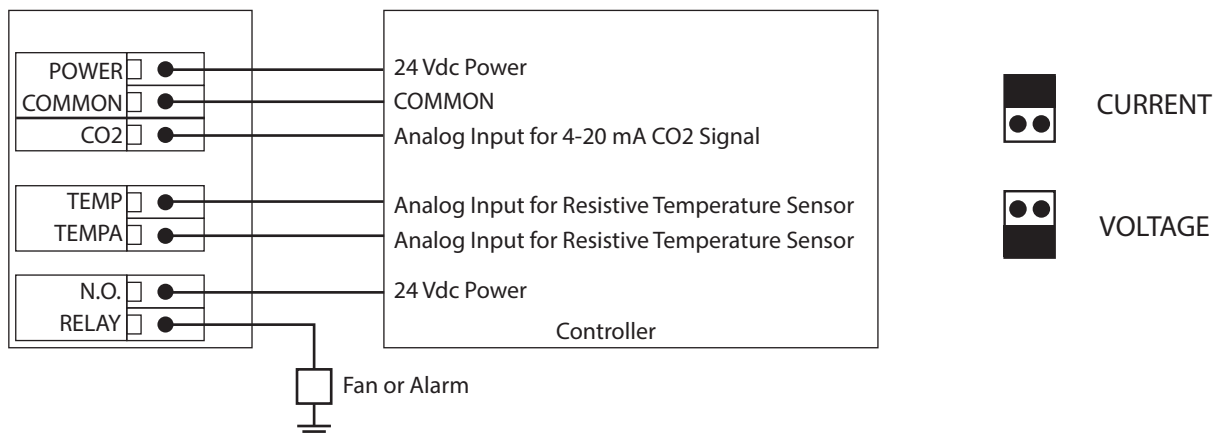

Figure 6

Typical 4-20 mA wiring with 24 Vdc and all options



## OUTPUTS

The CO2 output is scaled so that 4-20 mA (or 0-5/0-10Vdc) equals 0 to Out\_High as set in the user menu. The factory default is 0-20,000 ppm. The Out\_High can be changed in the user menu and the output signal is scaled accordingly. For voltage output models, the factory default is 0-5 Vdc and can be changed to 0-10 Vdc in the user menu.

## OPERATION

The CO2 signal is connected to the BAS analog input. The BAS reads the voltage or current signals and calculates actual values using correct scaling for the ranges and signal type. These values can be used to control ventilation devices or initiate alarms. All values are displayed locally on the LCD. The CO2 level will be displayed as 0-20,000 ppm.

If the optional relay is installed it can directly control a small fan or alarm by setting the trip value and hysteresis to appropriate values. The relay status is not indicated on the device LCD.

## USER MENU

The User Menu has several items as shown below. To enter the menu, press and release the <MENU> key while in normal operation. This will enter the User Menu step 1, pressing the <MENU> key a second time advances to step 2. Each press of the <MENU> key saves the selection and advances the menu item. The <ROLL> key is used to make changes to program variables by scrolling through the available options.

NOTE: If no keys are pressed for 5 minutes, the menu will automatically exit.

<MENU> Press and release to enter the setup menu.

*Out High*  
*20000 ppm*

Default CO2 range is 0-20,000 ppm. The output span can be changed from 2000 to 20,000 ppm in increments of 500. Use <ROLL> to change the value.

<MENU> Press to advance to next menu item

*Altitude*  
*0 ft*

The default is 0 feet. Change by using <ROLL> from 0 to 5000 feet in 500 foot increments for CO2 local altitude correction.

<MENU> Press to advance to next menu item

For models with the relay option installed

*Relay SP*  
*1000 ppm*

The relay trip setpoint default is 1000 ppm. Use <ROLL> to change from 500 to 5000 for single channel NDIR CO2 model in 100 ppm increments or from 500 to 15,000 for dual channel NDIR CO2 model in 100 ppm increments.

<MENU> Press to advance to next menu item

*Relay Hy*  
*50 ppm*

The relay hysteresis default is 50 ppm. Use <ROLL> to change from 25 to 200 for single channel NDIR CO2 model or from 25 to 500 for dual channel NDIR CO2 model in 25 ppm increments.

<MENU> Press to advance to next menu item

*Relay*  
*On Delay*

The relay on delay time default is 15 seconds. Use <ROLL> to change from 0 to 255 seconds in 1 second increments.

<MENU> Press to advance to next menu item

*Relay*  
*Test OFF*

Use <ROLL> to toggle the relay ON or OFF for testing purposes.

<MENU> Press to advance to next menu item

For models with the voltage output only

*Out Type*  
*0-5 Vdc*

The default output type is 0-5 Vdc. Use <ROLL> to change to 0-10 Vdc if necessary.

<MENU> Press to advance to next menu item

*Calibrat*  
*0 ppm*

This item is used for 0 ppm gas calibration and is explained in the *Calibration* section.

<MENU> Press to advance to next menu item

*Calibrat*  
*1000 ppm*

This item is used for 1000 ppm gas calibration and is explained in the *Calibration* section.

<MENU> Press to advance to next menu item

*Calibrat*  
*20000 ppm*

This item is used for 20,000 ppm gas calibration and is explained in the *Calibration* section.

<MENU> Press to advance to next menu item

*BackLite*  
*Auto*

Use <ROLL> to enable, disable, or set to auto the LCD backlight. When enabled the LCD backlight is always on, when disabled it never lights and if set to auto it lights for a time period of 30 seconds whenever a key is pressed. The factory default is Auto.

<MENU> Press to exit the menu and return to normal operation.

*Menu*  
*Exit*

Press <MENU> or <ROLL> to exit the menu and return to normal operation.

## **CALIBRATION**

CO<sub>2</sub> calibration with gas requires a field calibration kit with pressure regulator, necessary tubing and appropriate bottles of CO<sub>2</sub> gas. Note that the procedure depends on the device model.

### **DUAL CHANNEL CALIBRATION**

The dual-channel sensor with extended range requires a 3-point calibration with 0, 1000 and 20,000 ppm gas (in order).

### **0 PPM CALIBRATION**

Turn the regulator knob off and attach it to the Nitrogen gas bottle and hand tighten. Open the cover of the unit to be calibrated to expose the gas sensor port. Remove the plastic cap on the PCB and connect the tubing from the gas bottle. Turn the regulator knob on to allow the gas to flow to the sensor.

Enter the user menu and use the <MENU> key to advance to Calibrat 0 PPM. Press and hold the <SAVE> key for 2 seconds and the display will change to Waiting Calibrat then to Waiting 5 minute to indicate that the process of setting the internal calibration is taking place.

This takes about 5 minutes while the LCD counts down. Do not disturb the unit or the gas flow. When complete the unit will display the ppm value and Cal Done. Press <SAVE> to resume normal operation and shut the gas off.

## 1000 PPM CALIBRATION

Connect the 1000 ppm CO<sub>2</sub> gas bottle and apply the gas as before. The CO<sub>2</sub> reading on the LCD will begin to approach 1000 ppm. Wait 1 to 2 minutes until the CO<sub>2</sub> reading stabilizes.

Enter the user menu and use the <MENU> key to advance to Calibrat 1000 PPM. Press and hold the <SAVE> key for 2 seconds and the display will change to Waiting Calibrat then to Waiting 5 minute to indicate that the device is calibrating. Again, this process takes about 5 minutes. When calibration is complete the unit will display the ppm value and Cal Done. Press the <SAVE> key to return to normal operation and shut the gas off.

## 20,000 PPM CALIBRATION

Connect the 20,000 ppm CO<sub>2</sub> and apply the gas as before. The LCD will begin to approach 20,000 ppm. Wait 1 to 2 minutes until the CO<sub>2</sub> reading stabilizes.

Enter the user menu and use the <MENU> key to advance to Calibrat 20,000 PPM. Press and hold the <SAVE> key for 2 seconds and the display will change to Waiting Calibrat then to Waiting 5 minute.

Again, wait 5 minute and when calibration is complete the unit will display the ppm value and Cal Done. Press <SAVE> to resume normal operation and shut the gas off.

Disconnect the tubing and replace the cap on the sensor gas port as calibration is complete.

## DIMENSIONS

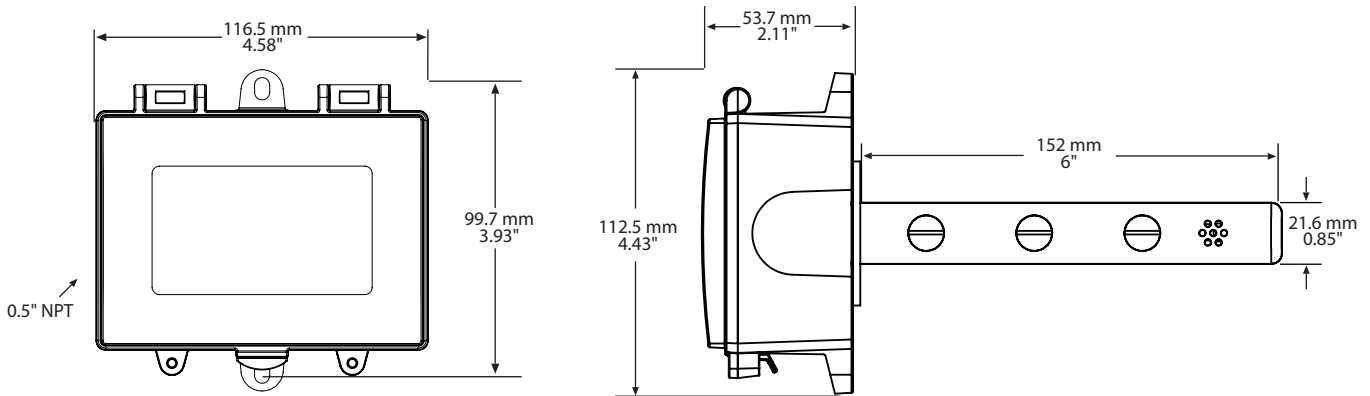

## SPECIFICATIONS:

Power Supply .....	20 - 28 Vac/dc (non-isolated half-wave rectified)
Consumption .....	<b>Current:</b> 120 mA max @ 24 Vdc, 212 mA max @ 24 Vac <b>Voltage:</b> 79 mA max @ 24 Vdc, 129 mA max @ 24 Vac
Output Signals.....	4-20 mA active (sourcing) or 0-5 Vdc / 0-10 Vdc (field selectable)
Output Drive Capability .....	550 ohms maximum for current output, 5 Kohm min for voltage output
Output Resolution .....	10 bit PWM
Input Voltage Effect.....	Negligible over specified operating range
Protection Circuitry.....	Reverse voltage protected, overvoltage protected
Operating Conditions .....	0 to 50°C (32 to 122°F), 0-95 %RH non-condensing
LCD Resolution .....	1 ppm CO2
LCD Size .....	35 mm W x 15 mm H (1.4" x 0.6") alpha-numeric 2 line x 8 characters
LCD Backlight.....	Enable or disable via keypad
Wiring Connections.....	Screw terminal blocks, 14 to 22 AWG
Enclosure .....	Duct mount, Grey polycarbonate with gasket, UL94-V0, IP65 (NEMA 4X) F style includes thread adapter (1/2" NPT to M16) and cable gland fitting 116.5 W x 112.5 H x 53.7 D mm (4.585" x 4.43" x 2.115")
Probe.....	152 mm L x 21.6 mm D (6" x 0.85")

## CO2 SIGNAL

Measurement Type .....	Non-Dispersive Infrared (NDIR), diffusion sampling
Measurement Range.....	0-20,000 ppm, programmable span
Standard Accuracy .....	+75ppm (400-1000 ppm) >1000 ppm, 10% of reading
Temperature Dependence .....	0.2 %FS per °C
Stability .....	<5 %F.S. over life of sensor (10 years typical)
Pressure Dependence.....	0.13% of reading per mm Hg
Altitude Correction .....	Programmable from 0-5000 ft via keypad
Response Time .....	<2 minutes for 90% step change typical
Warm-up Time .....	<2 minutes

## OPTIONAL TEMPERATURE SIGNAL

Sensing Element.....	Various RTDs or thermistors as 2-wire resistance output
----------------------	---

## OPTIONAL RELAY OUTPUT

Contact Ratings.....	Form A contact (N.O.), 2 Amps @ 140 Vac, 2 Amps @ 30 Vdc
Relay Trip Point.....	Programmable via keypad
Relay Hysteresis.....	Programmable via keypad

Country of Origin.....	Canada
------------------------	--------