

Modulating linear actuator for adjusting dampers and slide valves in technical building equipment

- Air damper size up to approx. 0.8 m²
- Actuating force 125 N
- Nominal voltage AC/DC 24 V
- Control modulating 2...10 V
- Position feedback 2...10 V
- Length of Stroke Max. 100 mm, adjustable in 20 mm increments

Technical data

Electrical data	Nominal voltage	AC/DC 24 V
	Nominal voltage frequency	50/60 Hz
	Nominal voltage range	AC 19.2...28.8 V / DC 19.2...28.8 V
	Power consumption in operation	1 W
	Power consumption in rest position	0.5 W
	Power consumption for wire sizing	1.5 VA
	Connection supply / control	Cable 1 m, 4 x 0.75 mm ²
	Parallel operation	Yes (note the performance data)
Functional data	Actuating force motor	125 N
	Operating range Y	2...10 V
	Input Impedance	100 kΩ
	Position feedback U	2...10 V
	Position feedback U note	Max. 1 mA
	Position accuracy	±5%
	Direction of motion motor	Y = 0 V: retracted
	Manual override	with magnet
	Stroke	100 mm
	Length of Stroke	Max. 100 mm, adjustable in 20 mm increments
	Stroke limitation	can be limited on both sides with mechanical end stops
	Running time motor	380 s / 100 mm
	Sound power level, motor	35 dB(A)
	Safety	Protection class IEC/EN
Protection class UL		UL Class 2 Supply
Degree of protection IEC/EN		IP54
Degree of protection NEMA/UL		NEMA 2
Enclosure		UL Enclosure Type 2
EMC		CE according to 2014/30/EU
Certification IEC/EN		IEC/EN 60730-1 and IEC/EN 60730-2-14
Certification UL		cULus according to UL60730-1A, UL60730-2-14 and CAN/CSA E60730-1:02
Mode of operation		Type 1
Rated impulse voltage supply / control		0.8 kV
Control pollution degree		3
Ambient temperature		-30...50 °C
Storage temperature	-40...80 °C	
Ambient humidity	Max. 95% r.H., non-condensing	
Servicing	maintenance-free	
Weight	Weight	0.38 kg
	Packaging quantity	Multipack 20 pcs.

Safety notes



- The device must not be used outside the specified field of application, especially not in aircraft or in any other airborne means of transport.
- Outdoor application: only possible in case that no (sea) water, snow, ice, insolation or aggressive gases interfere directly with the actuator and that is ensured that the ambient conditions remain at any time within the thresholds according to the data sheet.
- Only authorised specialists may carry out installation. All applicable legal or institutional installation regulations must be complied during installation.
- The device may only be opened at the manufacturer's site. It does not contain any parts that can be replaced or repaired by the user.
- Cables must not be removed from the device.
- The rotary supports and coupling pieces are available as accessories and must always be used if transverse forces are likely. An additional installation sheet is required in accordance with the installation instructions. In addition, the actuator must not be tightly bolted to the application. It must remain movable via the rotary support (refer to "Assembly notes").
- If the actuator is exposed to severely contaminated ambient air, appropriate precautions must be taken on the system side. Excessive deposits of dust, soot etc. can prevent the gear rod from being extended and retracted correctly.
- If the actuator is not installed horizontally, the magnet-operated gear disengagement may only be actuated when there is no pressure on the gear rod.
- To calculate the actuating force required for air dampers and slide valves, the specifications supplied by the damper manufacturers concerning the cross section, the design, the installation site and the ventilation conditions must be observed.
- If a rotary support and/or coupling piece is used, actuation force losses are to be expected.
- The device contains electrical and electronic components and must not be disposed of as household refuse. All locally valid regulations and requirements must be observed.

Product features

Mode of operation	The actuator is connected with a standard modulating signal of 0...10 V and drives to the position defined by the positioning signal. Measuring voltage U serves for the electrical display of the damper position 0.5...100% and as slave control signal for other actuators.
Simple direct mounting	The actuator can be directly connected with the application using the enclosed screws. The head of the gear rod is connected to the moving part of the ventilating application individually on the mounting side or with the Z-KS2 coupling piece provided.
Manual override	Manual override with magnet possible (gear disengagement as long as the magnet adheres to the magnet symbol). The Z-MA magnet for the gear disengagement is enclosed.
Adjustable stroke	If a stroke limitation will be adjusted, the mechanical operating range on this side of the gear rod can be used starting with an extension length of 20 mm and then can be limited respectively in increments of 20 mm by means of mechanical end stops Z-AS2. If the stroke limiters are used with the motor (with end stop clip Z-ESCM), the operating range can be limited on both sides. It can be adjusted in increments of 0.5 mm (calculatory 0.55 mm) from 0...40/60/67.5 mm.
High functional reliability	The actuator is overload protected, requires no limit switches and automatically stops when the end stop is reached.
Hidden synchronisation	If the actuator drives to the lower end stop during ongoing operation, then it performs a synchronisation of the positioning signal at DC 2 V. This ensures that the signal range also corresponds to the effective functional range in ongoing operation. The bottom end stop is actively approached as soon as the positioning signal is <DC 2.1 V. The actuator drives to the new specified position as soon as the positioning signal is once again >DC 2.3 V.

Accessories

	Description	Type
Mechanical accessories	End stop kit, Multipack 20 pcs.	Z-AS2
	Rotary support, for linear actuator	Z-DS1
	End stop clips, Multipack 20 pcs.	Z-ESCM
	Spring bracket, Multipack 20 pcs.	Z-FKCH
	Coupling piece M6	Z-KS2
	Gear disengagement magnet, Multipack 20 pcs.	Z-MA

Electrical installation



Notes

- Connection via safety isolating transformer.
- Parallel connection of other actuators possible. Observe the performance data.

Wiring diagrams

AC/DC 24 V, modulating

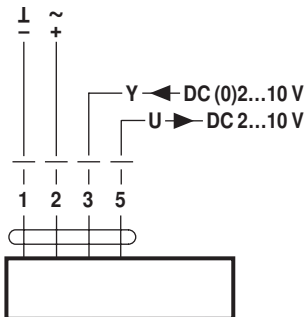

Installation notes



Notes

- If a rotary support and/or coupling piece is used, losses in the actuation force losses are to be expected.

Applications without transverse force

The linear actuator is screwed directly to the housing at two points. Afterwards, the head of the gear rod is fastened to the moving part of the ventilation application (e.g. damper or slide valve).

Applications with transverse forces

Connect the coupling piece with the internal thread (Z-KS2) to the head of the gear rod. Screw the rotary support (Z-DS1) to the ventilation application. Afterwards, the linear actuator is screwed to the previously mounted rotary support with the enclosed screw. Then, the coupling piece, which is mounted to the head of the gear rod, is attached to the moving part of the ventilating application (e.g. damper or slide valve). The transverse forces can be compensated for to a certain limit with the rotary support and/or coupling piece. The maximum permissible swivel angle of the rotary support and coupling piece is 10°, laterally and upwards.

Negative torque

If end stop clips (Z-ESCM) are used the following applies: ≤50% of the actuating force (Caution: Use possible only with restrictions. Please contact your supplier.)
 If end stops are used on the gear rod or at the application no restrictions apply.

Dimensions [mm]

Dimensional drawings

