

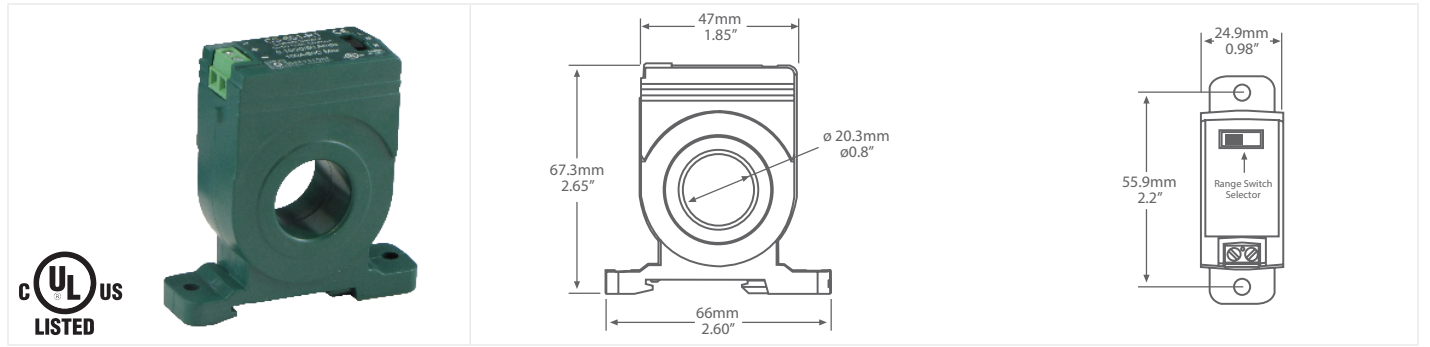

CURRENT SENSOR



CS-651

PRODUCT DESCRIPTION

The CS-651 series of mini current sensors monitor line current for electrical loads such as pumps, conveyors, machine tools or fans and provide an output of 0-10 Vdc to represent the load current.

The CS-651 requires no external power supply as they are totally powered by induction from the AC line being monitored.

TYPICAL INSTALLATION

For complete installation and wiring details, please refer to the product installation instructions.

The CS-651 series must be mounted in an electrical enclosure and has an integral mounting tab to allow screw mount to a surface.

The CS-651 series has a 2 wire connection to the Building Automation System.

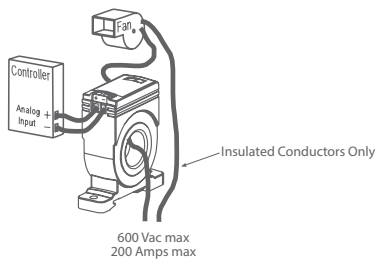

SPECIFICATIONS

MEASUREMENT RANGE	CS-651-R1: 0-10/20/50 Amps CS-651-100: 0-100 Amps CS-651-200: 0-200 Amps
MAXIMUM INPUT CURRENT	CS-651-R1: 100 Amps continuous CS-651-100: 150 Amps continuous CS-651-200: 250 Amps continuous
ACCURACY	CS-651-R1: $\pm 2\%$ FSO (5-100% of range) CS-651-100/200: $\pm 1\%$ FSO (5-100% of range)
SIGNAL OUTPUT	0-10 Vdc
SENSOR POWER	Self-powered
INSULATION CLASS	600 Vac, insulated conductors
FREQUENCY	50/60 Hz
RESPONSE TIME	200 mS typical, 0-90%
OUTPUT LOAD	1 M Ω typical
LOADING ERROR	Add 0.5% error with 100K Ω
OPERATING TEMPERATURE	-15 to 60°C (5 to 140°F)
OPERATING HUMIDITY	5 to 90 %RH non-condensing
TERMINAL BLOCK	14 to 22 AWG
DIMENSIONS	67mm W x 68.9mm H x 24.1mm D (2.65" x 2.7" x 0.95")
SENSOR APERTURE	20.3mm (0.8")
ENCLOSURE MATERIAL	ABS/PC, UL94-V0
AGENCY APPROVALS	cULus listed

ORDERING

PRODUCT	CS-651	Solid-Core Current Sensor, 0-10 Vdc Output
SENSING RANGE	R1 100 200	0-10/20/50 Amps - switch selectable 100 Amps continuous 150 Amps continuous 250 Amps continuous

PART NUMBER

CS-651

NOTE: Greystone Energy Systems, Inc. reserves the right to make design modifications without prior notice.