

Characterised control valve with sensor-operated flow rate or power control, power and energy-monitoring function, 3-way, Internal thread, PN 25 (Energy Valve)

- Nominal voltage AC/DC 24 V
- Control modulating, communicative, hybrid, Cloud
- For closed cold and warm water systems
- For modulating control of air-handling and heating systems on the water side
- Ethernet 10/100 Mbit/s, TCP/IP, integrated web server
- Communication via BACnet, Modbus, Belimo MP-Bus or conventional control
- optional Belimo Cloud connection
- Glycol monitoring

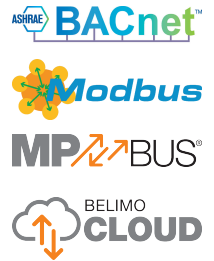
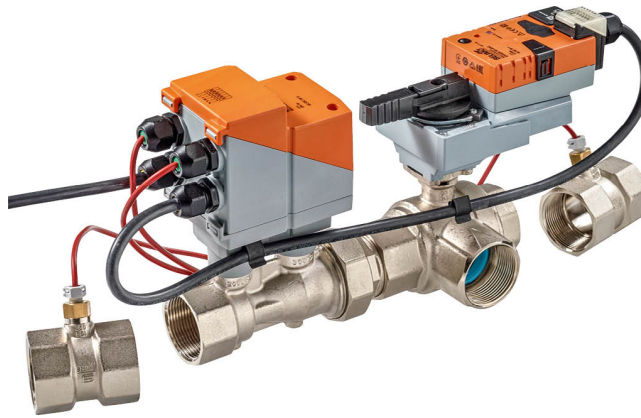

### Type Overview

Type	DN	Rp ["]	V'nom [l/s]	V'nom [l/min]	V'nom [m³/h]	kvs theor. [m³/h]	PN
EV015R3+BAC	15	1/2	0.35	21	1.26	2.9	25
EV020R3+BAC	20	3/4	0.65	39	2.34	4.9	25
EV025R3+BAC	25	1	1.15	69	4.14	8.6	25
EV032R3+BAC	32	1 1/4	1.8	108	6.48	14.2	25
EV040R3+BAC	40	1 1/2	2.5	150	9	21.3	25
EV050R3+BAC	50	2	4.8	288	17.28	32.0	25

kvs theor.: Theoretical kvs value for pressure drop calculation

### Technical data

<b>Electrical data</b>	Nominal voltage	AC/DC 24 V
	Nominal voltage frequency	50/60 Hz
	Nominal voltage range	AC 19.2...28.8 V / DC 21.6...28.8 V
	Power consumption in operation	4 W (DN 15, 20, 25) 5 W (DN 32, 40, 50)
	Power consumption in rest position	3.7 W (DN 15, 20, 25) 3.9 W (DN 32, 40, 50)
	Power consumption for wire sizing	6.5 VA (DN 15, 20, 25) 7.5 VA (DN 32, 40, 50)
	Connection supply / control	Cable 1 m, 6 x 0.75 mm <sup>2</sup>
	Connection Ethernet	RJ45 socket
	Parallel operation	Yes (note the performance data)
<b>Functional data</b>	Torque motor	5Nm (DN 15, 20, 25) 10Nm (DN 32) 20Nm (DN 40, 50)
	Communicative control	BACnet IP, BACnet MS/TP Modbus TCP, Modbus RTU MP-Bus Cloud
	Operating range Y	2...10 V
	Input Impedance	100 kΩ
	Operating range Y variable	0.5...10 V
	Position feedback U	2...10 V
	Position feedback U note	Max. 1 mA
	Position feedback U variable	0...10 V 0.5...10 V
	Sound power level Motor	35 dB(A) (DN 15, 20, 25, 32) 45 dB(A) (DN 40, 50)

	Adjustable flow rate V'max	30...100% of Vnom
	Control accuracy	±5% (of 25...100% V'nom) @ 20°C / Glycol 0% vol.
	Control accuracy note	±10% (of 25...100% V'nom) @ -10...120°C / Glycol 0...50% vol.
	Min. controllable flow	1% of V'nom
	Parametrisation	via integrated web server / ZTH EU
	Fluid	Cold and warm water, water with glycol up to max. 50% vol.
	Fluid temperature	-10...120°C
	Close-off pressure Δps	1400 kPa
	Differential pressure Δpmax	350 kPa
	Differential pressure note	200 kPa for low-noise operation
	Flow characteristic	equal percentage (VDI/VDE 2178), optimised in the opening range (switchable to linear)
	Leakage rate	air-bubble tight, leakage rate A (EN 12266-1)
	Pipe connection	Internal thread according to ISO 7-1
	Installation position	upright to horizontal (in relation to the stem)
	Servicing	maintenance-free
	Manual override	with push-button, can be locked
<b>Flow measurement</b>	Measuring principle	Ultrasonic volumetric flow measurement
	Measuring accuracy flow	±2% (of 25...100% V'nom) @ 20°C / Glycol 0% vol.
	Measuring accuracy flow note	±6% (of 25...100% V'nom) @ -10...120°C / Glycol 0...50% vol.
	Min. flow measurement	0.5% of V'nom
<b>Temperature measurement</b>	Measuring accuracy absolute temperature	± 0.35°C @ 10°C (Pt1000 EN60751 Class B) ± 0.6°C @ 60°C (Pt1000 EN60751 Class B)
	Measuring accuracy temperature difference	±0.18 K @ ΔT = 10 K ±0.23 K @ ΔT = 20 K
	Resolution	0.05°C
<b>Glycol monitoring</b>	Measurement display glycol	0...40% or >40%
	Measuring accuracy glycolmonitoring	±4% (0...40%)
<b>Safety data</b>	Protection class IEC/EN	III Protective extra-low voltage (PELV)
	Degree of protection IEC/EN	IP40
	Degree of protection note	IP54 when using protective cap or protective grommet for RJ45 socket
	Pressure equipment directive	CE according to 2014/68/EU
	EMC	CE according to 2014/30/EU
	Mode of operation	Type 1
	Rated impulse voltage supply / control	0.8 kV
	Control pollution degree	3
	Ambient temperature	-30...50°C
	Storage temperature	-40...80°C
	Ambient humidity	Max. 95% r.H., non-condensing
<b>Materials</b>	Flow measuring pipe	Brass body nickel-plated
	Closing element	Stainless steel
	Stem seal	EPDM O-ring
	Immersion sleeve	Brass
	T-Piece	Nickel-plated brass body

**Safety notes**



- This device has been designed for use in stationary heating, ventilation and air-conditioning systems and must not be used outside the specified field of application, especially in aircraft or in any other airborne means of transport.
- Outdoor application: only possible in case that no (sea) water, snow, ice, insulation or aggressive gases interfere directly with the device and that it is ensured that the ambient conditions remain within the thresholds according to the data sheet at any time.
- Only authorised specialists may carry out installation. All applicable legal or institutional installation regulations must be complied during installation.
- The connection between the control valve and the measuring tube should not be separated.
- The device contains electrical and electronic components and must not be disposed of as household refuse. All locally valid regulations and requirements must be observed.

**Product features**

**Mode of operation** The HVAC performance device is comprised of four components: characterised control valve (CCV), measuring pipe with volumetric flow sensor, temperature sensors and the actuator itself. The adjusted maximum flow ( $V'_{max}$ ) is assigned to the maximum positioning signal (typically 10 V / 100%). Alternatively, the positioning signal can be assigned to the valve opening angle or to the power required on the heat exchanger (see power control). The HVAC performance device can be controlled via communicative or analogue signals. The fluid is detected by the sensor in the measuring pipe and is applied as the flow value. The measured value is balanced with the setpoint. The actuator corrects the deviation by changing the valve position. The angle of rotation  $\alpha$  varies according to the differential pressure through the control element (see flow rate curves).

**3-way characterised control valve** 3-way characterised control valves are mixing devices. The direction of flow must be observed in every load case. The installation in supply or return depends on the selected hydronic circuit. The 3-way characterised control valve must not be used as a diverting valve.

**Hydronics** The 3-way Belimo Energy Valve is intended for use in a system with low pressure manifolds.



This design results in approximately the same pressures in the flow and return manifold ( $\Delta p_{VR1} \approx \Delta p_{VR2}$ ).

The valve is therefore used in a mixing circuit. The constant flow rate flowing through the consumer is determined by the internal pump. The 3-way Belimo Energy Valve only affects the mixing ratio flow rate/ bypass. The valve position influences the amount of return water added to the flow via the Bypass.

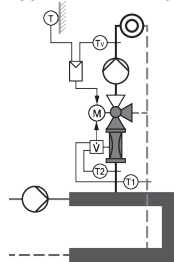

**Flow characteristic**

**Flow rate curves**

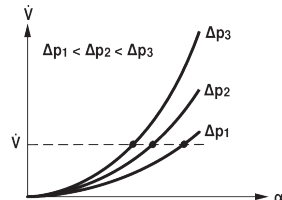

**Transmission behaviour HE** Heat exchanger transmission behaviour

Depending on the construction, temperature spread, fluid characteristics and hydronic circuit, the power  $Q$  is not proportional to the water volumetric flow  $V'$  (Curve 1). With the classical type of temperature control, an attempt is made to maintain the control signal  $Y$  proportional to the power  $Q$  (Curve 2). This is achieved by means of an equal-percentage valve characteristic curve (Curve 3).

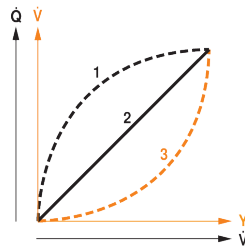

**Power control** Alternatively, the positioning signal Y can be assigned to the output power required at the heat exchanger.

Depending on the water temperature and air conditions, the Energy Valve ensures the amount of water V' required to achieve the desired power.

**Maximum controllable power on heat exchanger in power control mode:**

DN 15	80 kW
DN 20	140 kW
DN 25	250 kW
DN 32	380 kW
DN 40	530 kW
DN 50	1010 kW

**Control characteristics** The specially configured control parameters in connection with the precise velocity sensor ensure a stable quality of control. They are, however, not suitable for rapid control processes, i.e. for domestic water control.

**Definition** Flow control  
V'nom is the maximum possible flow.

V'max is the maximum flow rate which has been set with the highest positioning signal. V'max can be set between 30% and 100% of V'nom.

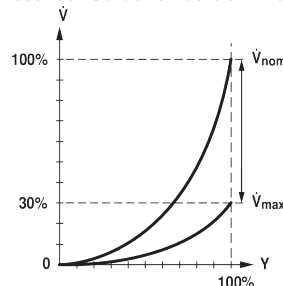

**Definition** Power control  
Q'nom is the maximum possible power output on the heat exchanger.

Q'max is the maximum power output on the heat exchanger which has been set with the highest positioning signal. Q'max can be set between 1% and 100% of Q'nom.

Q'min 0% (non-variable).

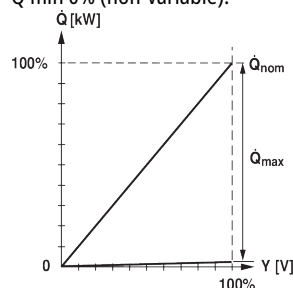

**Position control** In this setting, the control signal is assigned to the opening angle of the valve (e.g. Y = 10 V corresponds to  $\alpha = 90^\circ$ ). The result is a pressure-dependent operation similar to that of a conventional valve.

**Creep flow suppression**

Given the very low flow speed in the opening point, this can no longer be measured by the sensor within the required tolerance. This range is overridden electronically.

**Opening valve**

The valve remains closed until the volumetric flow required by the positioning signal Y corresponds to 1% of V'nom. The control along the valve characteristic curve is active after this value has been exceeded.

**Closing valve**

The control along the valve characteristic curve is active up to the required flow rate of 1% of V'nom. Once the level falls below this value, the flow rate is maintained at 1% of V'nom. If the level falls below the flow rate of 0.5% of V'nom required by the reference variable Y, then the valve will close.

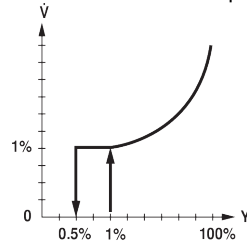

**Communication**

The parametrisation can be carried out through the integrated web server (RJ45 connection to the web browser) or by communicative means.

Additional information regarding the integrated web server can be found in the separate documentation.

**"Peer to Peer" connection**

<http://belimo.local:8080>

The Notebook must be set to "DHCP".

Make sure that only one network connection is active.

**Standard IP address:**

<http://192.168.0.10:8080>

Static IP address

**Password (read-only):**

User name: «guest»

Password: «guest»

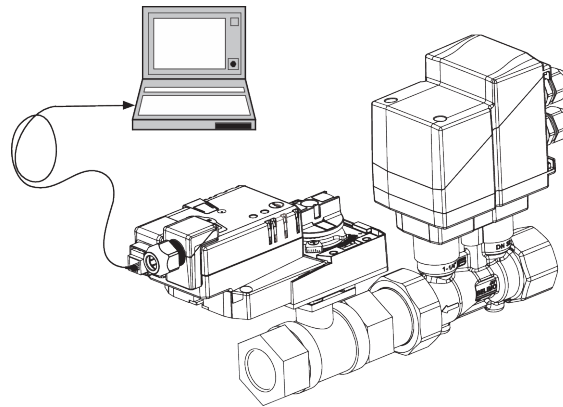

**Positioning signal inversion**

This can be inverted in cases of control with an analogue positioning signal. The inversion causes the reversal of the standard behaviour, i.e. at a positioning signal of 0%, regulation is to V'max or Q'max, and the valve is closed at a positioning signal of 100%.

**Hydronic balancing**

Via the integrated web server, the maximum flow rate (equivalent to 100% requirement) can be adjusted on the device itself, simply and reliably, in a few steps. If the device is integrated in the management system, then the balancing can be handled directly by the management system.

**Delta-T manager**

If a heating or cooling register is operated with a differential temperature that is too low and thus with a flow rate that is too high, this will not result in an increased power output.

Nevertheless, heating or cooling machines must provide the energy at a lower degree of efficiency. This means, that pumps circulate too much water and increase energy consumption unnecessarily.

With the aid of the Energy Valve, it is simple to discover that operation is being carried out at a differential temperature that is too low, resulting in the inefficient use of energy.

Necessary setting adjustments can now be carried out quickly and easily at any time. The integrated differential temperature limiting offers the user the possibility of defining a low limit value. The Energy Valve limits the flow rate automatically to prevent the level from falling below this value.

The settings of the Delta-T manager can be made either directly on the web server or via the Belimo Cloud a direct analysis of the Delta-T behavior is carried out by Belimo experts.

Power output of the heating or cooling registers

1

Diff. temperature between supply and return

2

Loss zone (heating or cooling register saturation)

3

Adjustable minimum differential temperature

4

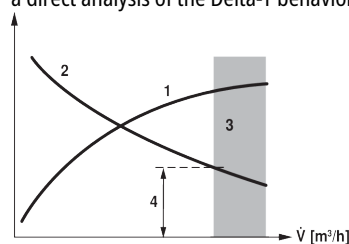

**Combination analogue - communicative (hybrid mode)**

With conventional control by means of an analogue positioning signal, the integrated web server, BACnet, Modbus or MP-Bus can be used for the communicative position feedback.

**Power and energy monitoring function**

The final controlling device is equipped with two temperature sensors. A sensor (T2) must be installed at the valve and the second sensor (T1) must be installed on-site on the other side of the water circulation. The two sensors are enclosed with the system already wired. The sensors are used to record the fluid temperature of the supply and return lines of the consumer (heating/cooling coil). As the water quantity is also known, thanks to the volumetric flow measurement integrated in the system, the power released from the consumer can be calculated. Furthermore, the heating/cooling energy is also determined automatically by means of the evaluation of the power over time.

The current data, e.g. temperatures, volumetric flow volumes, exchanger energy consumption etc. can be recorded and accessed at any time by means of web browsers or communication.

**Data recording**

The recorded data (integrated data recording for 13 months) can be used for the optimisation of the overall system and for the determination of the performance of the consumer.

Download csv files through web browser.

**Belimo Cloud**

Additional services are available if the Energy Valve is connected to the Belimo Cloud: for instance, several devices may be managed via Internet. Also, Belimo experts may help analyse the delta-T behaviour or provide written reports about the Energy Valve performance. Under certain conditions, the product guarantee according to the applicable Terms and Conditions of Sale may be prolonged. The "Terms of Use for Belimo Cloud Services" in their currently valid version apply to the use of Belimo Cloud services. Further details may be found under [[www.belimo.com/ext-warranty](http://www.belimo.com/ext-warranty)]

**Glycol monitoring**

Glycol monitoring measures the actual glycol content, which is necessary for safe operation and optimised heat exchange.

**Manual override**

Manual override with push-button possible (the gear is disengaged for as long as the button is pressed or remains locked).

**High functional safety**

The actuator is overload protected, requires no limit switches and automatically stops when the end stop is reached.

**Accessories**

Electrical accessories	Description	Type
	Grommet for RJ connection module, 50 pcs.	Z-STRJ.1
	Connection cable 5 m, A: RJ11 6/4 ZTH EU, B: 6-pin for connection to service socket	ZK1-GEN
Mechanical accessories	Description	Type
	Pipe connector for ball valve DN 15 Rp 1/2	ZR2315
	Pipe connector for ball valve DN 20 Rp 3/4	ZR2320
	Pipe connector for ball valve DN 25 Rp 1	ZR2325
	Pipe connector for ball valve DN 32 Rp 1 1/4	ZR2332
	Pipe connector for ball valve DN 40 Rp 1 1/2	ZR2340
	Pipe connector for ball valve DN 50 Rp 2	ZR2350
Service tools	Description	Type
	Service Tool, with ZIP-USB function, for parametrisable and communicative Belimo actuators, VAV controller and HVAC performance devices	ZTH EU

**Electrical installation**



Supply from isolating transformer.

Parallel connection of other actuators possible. Observe the performance data.

The wiring of the line for BACnet MS/TP / Modbus RTU is to be carried out in accordance with applicable RS485 regulations.

Modbus / BACnet: Supply and communication are not galvanically isolated. Connect earth signal of the devices with one another.

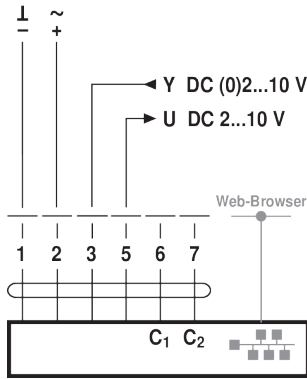
Conventional operation



Cable colours:

- 1 = black
- 2 = red
- 3 = white
- 5 = orange
- 6 = pink
- 7 = grey

Web-Browser



Connection of a notebook for parametrisation and manual control via RJ45.

Optional connection via RJ45 (direct connection Notebook / connection via Intranet or Internet) for access to the integrated web server

MP-Bus, supply via 3-wire connection

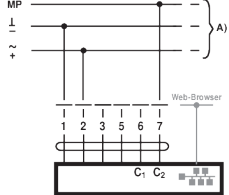

A) additional MP-Bus nodes (max. 8)

MP-Bus via 2-wire connection, local power supply

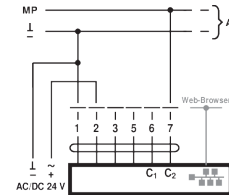

A) additional MP-Bus nodes (max. 8)

MP-Bus Network topology

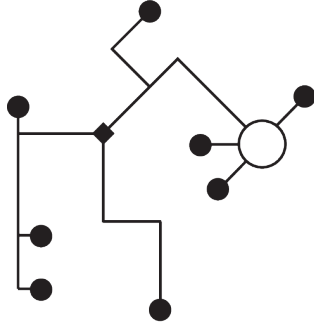

There are no restrictions for the network topology (star, ring, tree or mixed forms are permitted). Supply and communication in one and the same 3-wire cable

- no shielding or twisting necessary
- no terminating resistors required

Functions

Functions for actuators with specific parameters (Parametrisation necessary)

BACnet MS/TP / Modbus RTU

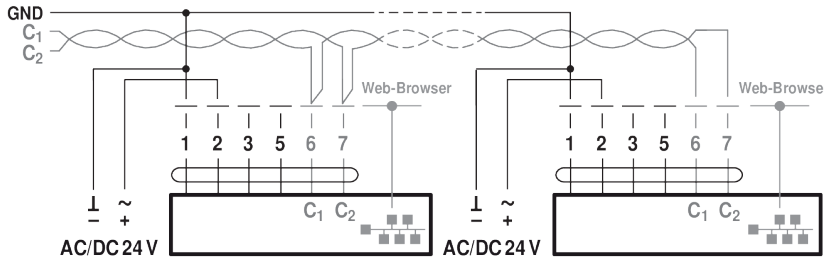

C<sub>1</sub> = D- = A  
C<sub>2</sub> = D+ = B

BACnet IP / Modbus TCP

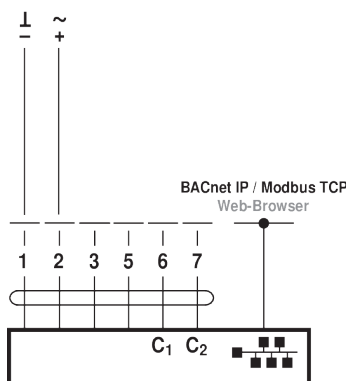

MP-Bus with analog setpoint (hybrid mode)

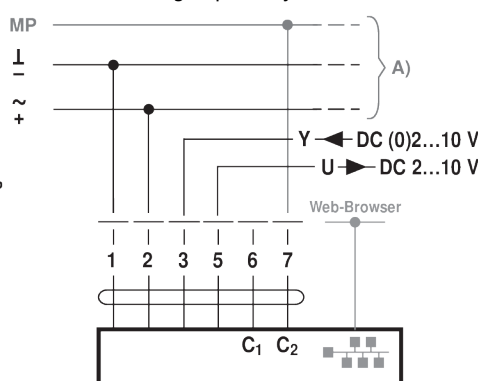

BACnet MS/TP / Modbus RTU with analog setpoint (hybrid mode)

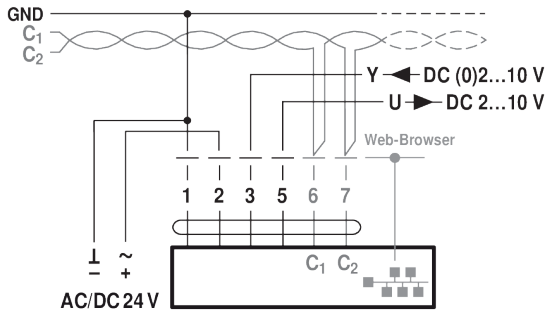

BACnet IP / Modbus TCP with analog setpoint (hybrid mode)

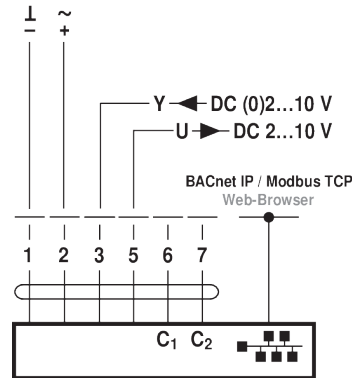

Override control and limiting with DC 24 V with relay contacts (with conventional control or hybrid mode)

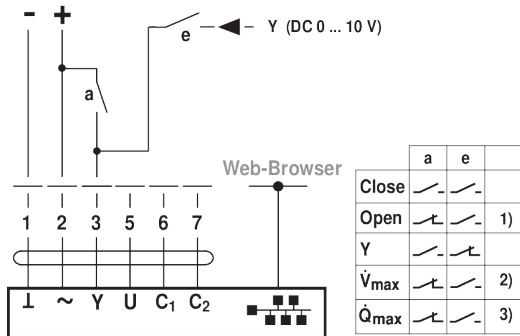

- 1) Position control
- 2) Flow control
- 3) Power control

**Operating controls and indicators**

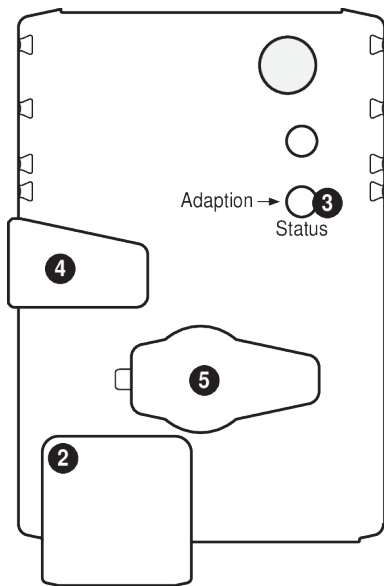

- 2 LED display green**  
 Off: No power supply or wiring errors  
 On: In operation  
 Flickering: Internal communication (Valve/Sensor)
- 3 Push-button and LED display yellow**  
 On: Adaptation process active  
 Press button: Triggers angle of rotation adaptation, followed by standard mode
- 4 Gear disengagement button**  
 Press button: Gear disengages, motor stops, manual override possible  
 Release button: Gear engages, synchronisation starts, followed by standard mode
- 5 Service plug**  
 For connecting the ZTH EU

**Installation notes**

**Recommended installation positions**

The ball valve can be installed upright to horizontal. The ball valve may not be installed in a hanging position, i.e. with the stem pointing downwards.

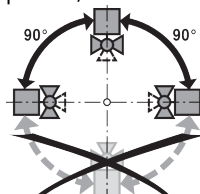



**Water quality requirements**

The water quality requirements specified in VDI 2035 must be adhered to.

Belimo valves are regulating devices. For the valves to function correctly in the long term, they must be kept free from particle debris (e.g. welding beads during installation work). The installation of a suitable strainer is recommended.

**Servicing**

Ball valves, rotary actuators and sensors are maintenance-free.

Before any service work on the final controlling device is carried out, it is essential to isolate the rotary actuator from the power supply (by unplugging the electrical cable if necessary). Any pumps in the part of the piping system concerned must also be switched off and the appropriate slide valves closed (allow all components to cool down first if necessary and always reduce the system pressure to ambient pressure level).

The system must not be returned to service until the ball valve and the rotary actuator have been correctly reassembled in accordance with the instructions and the pipeline has been refilled by professionally trained personnel.

**Flow direction**

The direction of flow, specified by an arrow on the housing, is to be complied with, since otherwise the flow rate will be measured incorrectly.

**Inlet section**

In order to achieve the specified measuring accuracy, a flow-calming section or inflow section in the direction of the flow is to be provided upstream from the flow sensor. Its dimensions should be at least 5x DN.

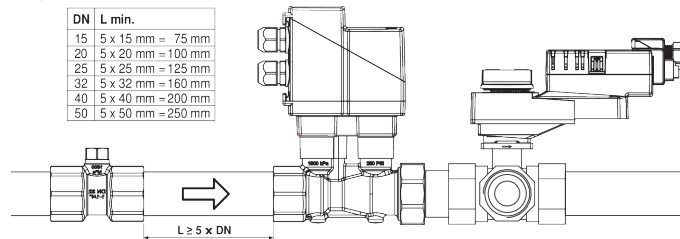

**Mounting of immersion sleeve and temperature sensor**

The valve is equipped with two fully-wired temperature sensors.

- T2: This sensor is installed on site near the valve unit.
- T1: This sensor is installed on site ahead of the consumer (valve in the return line) or after the consumer (valve in the supply line).

Two T-pieces for installation of the temperature sensors in the pipelines are included in the shipment.

**Note**

The cables between valve unit and temperature sensors may not be either shortened or lengthened.

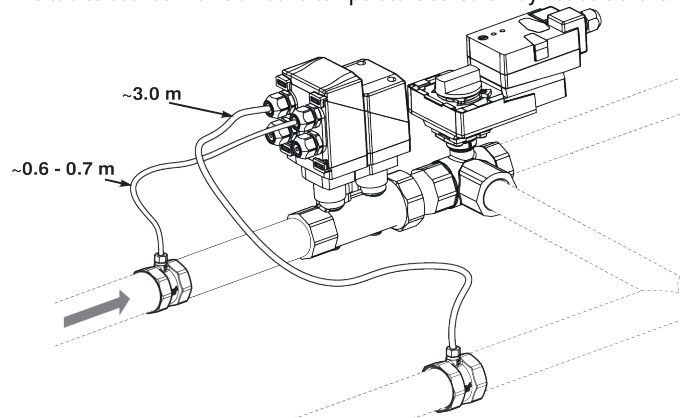

**Split installation**

The valve-actuator combination may be mounted separately from the flow sensor. The direction of flow must be observed.

**General notes**

**Minimum differential pressure (pressure drop)**

The minimum required differential pressure (pressure drop through the valve) for achieving the desired volumetric flow  $V'_{max}$  can be calculated with the aid of the theoretical kvs value (see type overview) and the below-mentioned formula. The calculated value is dependent on the required maximum volumetric flow  $V'_{max}$ . Higher differential pressures are compensated for automatically by the valve.

**Formula**

$$\Delta p_{\min} = 100 \times \left( \frac{\dot{V}_{\max}}{k_{vs \text{ theor.}}} \right)^2$$

$\Delta p_{\min}: \text{kPa}$

$\dot{V}_{\max}: \text{m}^3/\text{h}$

$k_{vs \text{ theor.}}: \text{m}^3/\text{h}$

**Example (DN 25 with the desired maximum flow rate = 50% V<sub>nom</sub>)**

EV025R3+BAC  
 kvs theor. = 8.6 m<sup>3</sup>/h  
 V<sub>nom</sub> = 69 l/min  
 50% \* 69 l/min = 34.5 l/min = 2.07 m<sup>3</sup>/h

$$\Delta p_{\min} = 100 \times \left( \frac{\dot{V}_{\max}}{k_{vs \text{ theor.}}} \right)^2 = 100 \times \left( \frac{2.07 \text{ m}^3/\text{h}}{8.6 \text{ m}^3/\text{h}} \right)^2 = 6 \text{ kPa}$$

**Behaviour in case of sensor failure**

In case of a flow sensor error, the Energy Valve will switch from either power or flow control to position control (Delta-T manager will be deactivated).

Once the error disappears, the Energy Valve will switch back to the normal control setting (Delta-T manager activated)

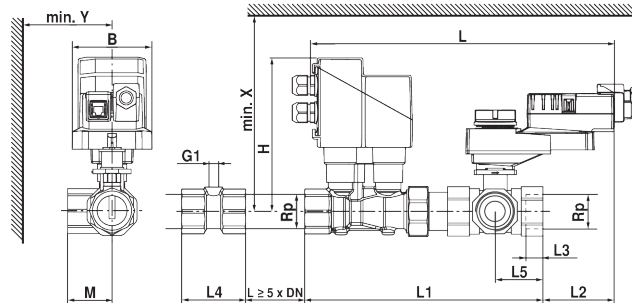
**Dimensions**
**Dimensional drawings**

Type	DN	Rp ["]	L [mm]	L1 [mm]	L2 [mm]	L3 [mm]	L4 [mm]	L5 [mm]	B [mm]	H [mm]	G1 ["]	X [mm]	Y [mm]	 kg
EV015R3+BAC	15	1/2	280	187	84	13	53	35.5	75	160	G1/4	230	77	1.8
EV020R3+BAC	20	3/4	290	208	79	14	57	41	75	162	G1/4	232	77	2.5
EV025R3+BAC	25	1	294	224	72	16	65	44.5	75	165	G1/4	235	77	2.5
EV032R3+BAC	32	1 1/4	319	255	72	19	71	55.5	85	168	G1/4	238	77	2.8
EV040R3+BAC	40	1 1/2	345	279	72	19	71	64.5	85	172	G1/4	242	77	4.0
EV050R3+BAC	50	2	358	305	63	22	80	75	95	177	G1/4	247	77	7.2

**Further documentation**

- Tool connections
- Description Protocol Implementation Conformance Statement PICS
- Description Modbus register
- Description Data-Pool Values
- Overview MP Cooperation Partners
- MP Glossary
- Introduction to MP-Bus Technology
- Notes for project planning for 3-way Energy Valve
- Instruction Webserver