

Minimum 320 in-lb torque**

- For damper areas up to 80 sq-ft*

Applications

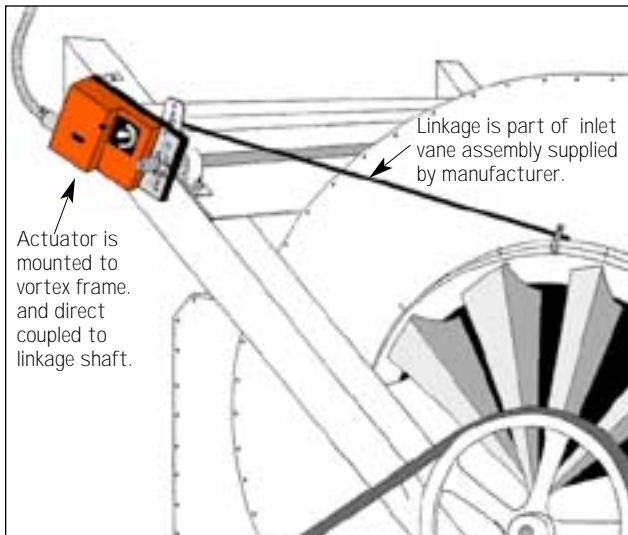

For large damper areas and inlet guide vanes.

GM Series – at a glance

	GM24 US (p. 70)	GM24-SR US (p. 72)	GM24-MFT US
Torque:	320 in-lb	266 in-lb	320 in-lb
Power supply : 24 VAC	●	●	●
Control signal: on-off	●		
Control signal: proportional 2 to 10 VDC		●	●†
Feedback signal: 2 to 10 VDC		●	●†
Running time 135 sec constant	●	●	●†
External direction of rotation switch	●	●	●
18 GA appliance cable	●	●	●
Installation instructions(p. 74–78)	General wiring(p. 76)		
Start-up and checkout(p. 79)			

* 4 in-lb/ft² damper torque loading. Parallel blade. No edge seals. 320 in-lb of actuator torque.

**GM24-SR US Only is 266 in-lb

†Variable: Refer to Multi-Function Product Documentation for details.

A CLOSER LOOK...



- Cut labor costs with simple direct coupling – The Belimo Concept.
- Check damper position easily with clear indicator.
- Don't worry about actuator burn-out. Belimo is overload-proof throughout rotation.
- Easy mechanical stop to adjust angle of rotation. (add ZDB-GM accessory).
- Push-button manual override speeds installation.
- Need to change control direction? Do it easily with a simple switch.
- Microprocessor-controlled brushless DC motor increases actuator life span and reliability, provides constant running time.
- Rugged NEMA 2 housing provides protection from splashing water.
- 3 ft. appliance cable and conduit connector eases installation.
- Microprocessor controlled.

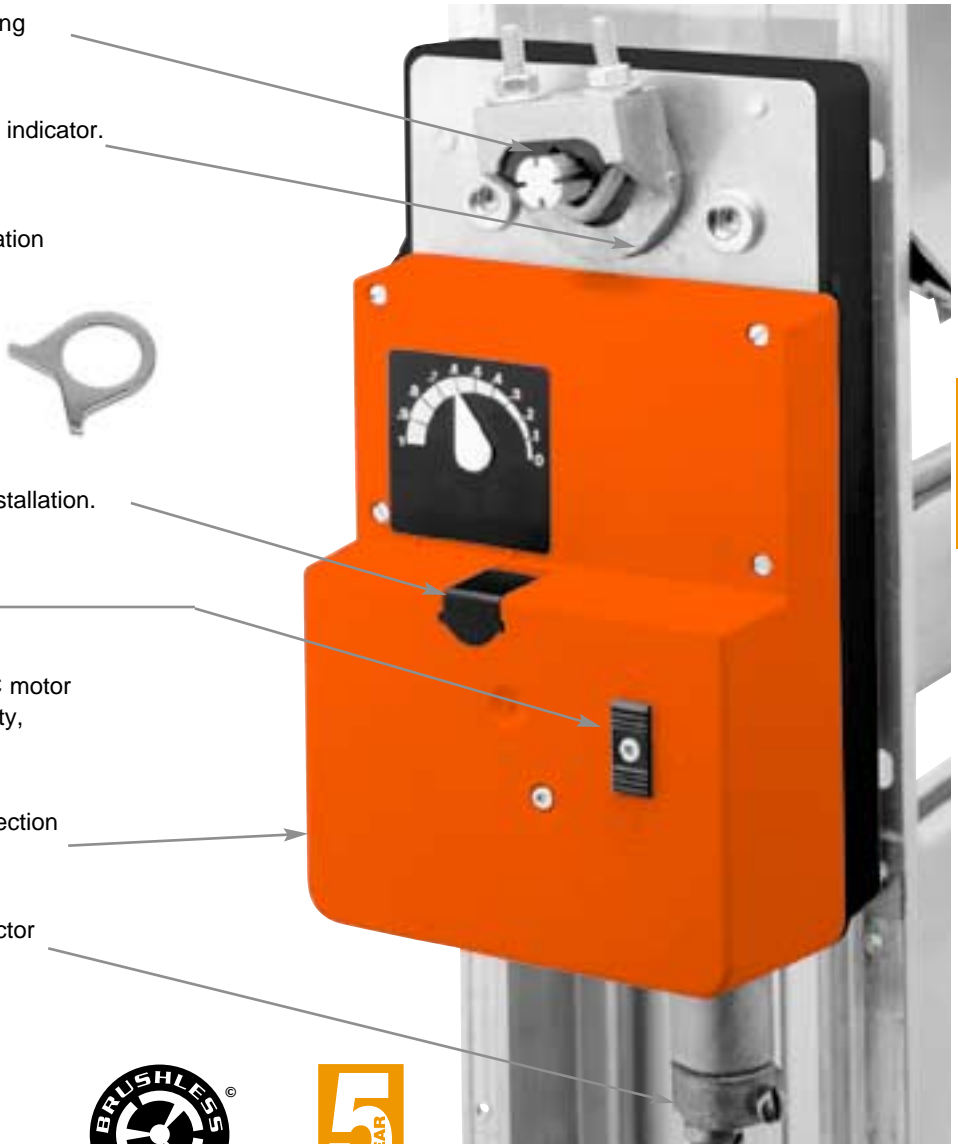

The Belimo Difference

- **Customer Commitment.**
Extensive product range. Competitive project pricing. Application assistance. Same-day shipments. Free technical support. Five year warranty.
- **Low Installation and Life-Cycle Cost.**
Easy installation. Accuracy and repeatability. Low power consumption. No maintenance.
- **Long Service Life.**
Components tested before assembly. Every product tested before shipment. 20+ years direct coupled actuator design.

F20358 / 5 4 3 2 1 -01/04-10M-IG-Subject to change. © Belimo Aircontrols (USA), Inc.

GM

On-off, reversible, non-spring return, direct coupled, tri-state, 24 V



Torque min. 320 in-lb, for control of air dampers

Application

For modulating or on-off control of dampers in HVAC systems. Actuator sizing should be done in accordance with the damper manufacturer's specifications. Control is on-off from an auxiliary contact of a fan motor contactor, or a manual switch. The direction of rotation is reversible, for use with a floating point type control. The actuator mounts directly to the damper operating shaft with a universal V-bolt clamp assembly.

Operation

The anti-rotation strap supplied with the actuator will prevent lateral movement of the actuator. The angle of rotation is mechanically limited to 95°. When reaching the damper or actuator end position, the motor stops automatically. The gears can be manually disengaged by simply pressing down the spring loaded button on the actuator cover. When this button is pressed down, the damper blades can be adjusted by hand. The position of the actuator is indicated by means of a scale reading 0 to 1.

The GM uses a brushless DC motor which is controlled by an Application Specific Integrated Circuit (ASIC). The ASIC monitors and controls the actuator's rotation and provides a digital rotation sensing function to prevent damage to the actuator in a stall condition. The actuator may be stalled anywhere in its normal rotation without the need of mechanical end switches.

Technical Data	GM24 US
Power supply	24 VAC ± 20% 50/60 Hz 24 VDC ± 10%
Power consumption	3 W
Transformer sizing	6 VA (class 2 power source)
Electrical connection	3 ft, 18 GA appliance cable 1/2" conduit connector
Overload protection	Electronic throughout 0 to 95° rotation
Angle of rotation	mechanically limited to 95°
Torque	320 in-lb [36 Nm] starting in June 2002
Direction of rotation	reversible with switch A/B
Position indication	0 to 1 and reversible indicator
Running time	135 sec. independent of load
Humidity	5 to 95% RH non-condensing
Ambient temperature	-22°F to +122°F [-30°C to +50°C]
Storage temperature	-40°F to +176°F [-40°C to +80°C]
Housing	NEMA type 2
Housing rating	UL94V-0 (flammability rating)
Agency listings	UL 873 listed, CSA C22.2 No.24 certified, CE
Noise level	max. 45 dB (A)
Servicing	maintenance free
Quality standard	ISO 9001
Weight	4.0 lbs (1.8 kg.)

Dimensions (All numbers in brackets are metric.)

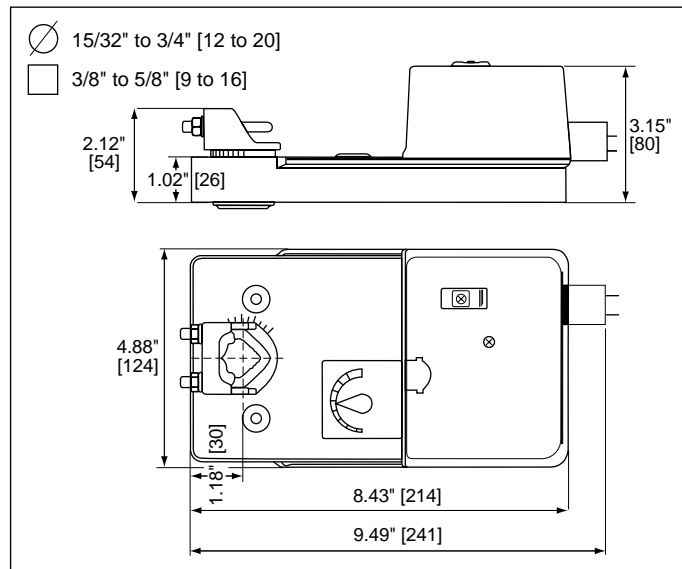

Accessories

KH8	Universal crankarm
KG10	Ball joint
NSV24	Battery back-up module
P...	Feedback potentiometer
SZS	Mid-position switch
S1,S2	Auxiliary switch
Tool-01	10mm wrench
ZDB-GM	Angle of rotation limiter (Series 2)
ZG-H2	Actuator operator handle
ZG-GM2	Crankarm adaptor kit
ZG-100	Universal mounting bracket
ZG-101	Universal mounting bracket
ZG-102	Multiple actuator mounting bracket
ZG-103	Universal mounting bracket
ZG-104	Universal mounting bracket
ZS-100	Weather shield (metal)
ZS-150	Weather shield (polycarbonate)
ZS-260	Explosion-proof housing
ZS-300	NEMA 4X housing

NOTE: When using GM24 US actuators, use only the accessories listed on this page.

GM24 US - Typical Specification:

Control damper actuators shall be electronic direct coupled type which require no crankarm and linkage. Actuators shall be UL listed and CSA certified, have a 2 year warranty, and be manufactured under ISO 9001 International Quality Control Standards. Actuators shall have reversing switch and manual override on the cover. Actuators shall use a brushless DC motor and be protected from overload at all angles of rotation. Run time shall be constant and independent of torque. Actuators shall be as manufactured by Belimo.

Multiple actuators mounted to shaft	
Model	Maximum quantity per shaft
GM24 US	2
GM24-SR US	2

Wiring diagrams

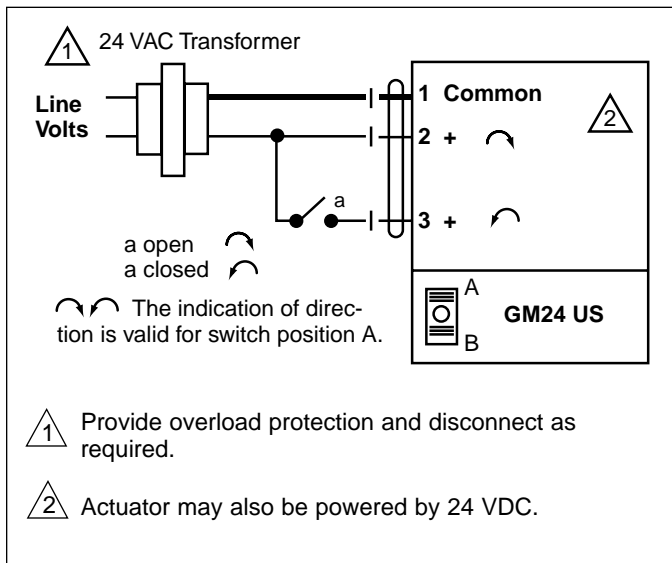

On-Off control of GM24 US

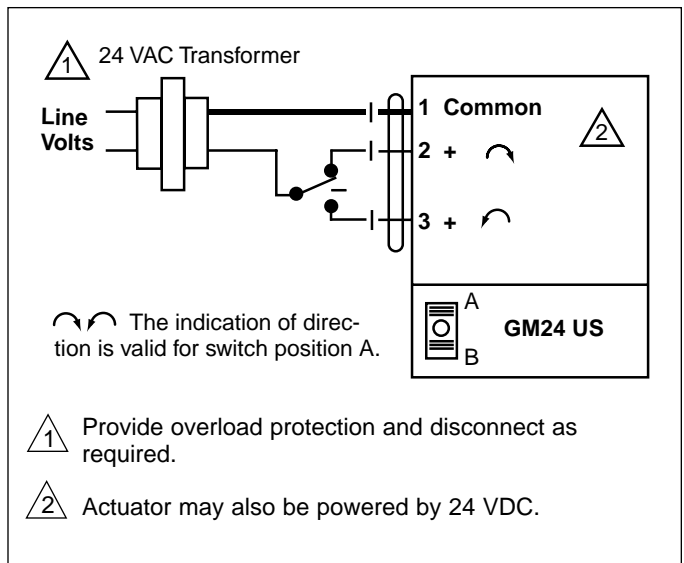

Tri-State control of GM24 US

GM24-SR US



Proportional damper actuator, non-spring return, direct coupled,
24 V for 2 to 10 VDC and 4 to 20 mA control signal.



Torque min. 266 in-lb, for control of air dampers

Application

For proportional modulation of dampers in HVAC systems. Actuator sizing should be done in accordance with the damper manufacturer's specifications.

The actuator mounts directly to the damper operating shaft with a universal V-bolt clamp assembly.

Operation

The actuator operates in response to a 2 to 10 VDC or, with the addition of a 500Ω resistor, a 4 to 20 mA control input from an electronic controller or positioner. A 2 to 10 VDC feedback signal is provided for position indication or master-slave applications.

The anti-rotation strap supplied with the actuator will prevent lateral movement of the actuator. The angle of rotation is mechanically limited to 95°. When reaching the damper or actuator end position, the motor stops automatically. The gears can be manually disengaged by simply pressing down the spring loaded button on the actuator cover. When this button is pressed down, the damper blades can be adjusted by hand. The position of the actuator is indicated by means of a scale reading 0 to 1.

The GM uses a brushless DC motor which is controlled by an Application Specific Integrated Circuit (ASIC). The ASIC monitors and controls the actuator's rotation and provides a digital rotation sensing function to prevent damage to the actuator in a stall condition. The actuator may be stalled anywhere in its normal rotation without the need of mechanical end switches.

Technical Data	GM24-SR US
Power supply	24 VAC ± 20% 50/60 Hz 24 VDC ± 10%
Power consumption	3 W
Transformer sizing	7 VA (class 2 power source)
Electrical connection	3 ft, 18 GA appliance cable 1/2" conduit connector
Overload protection	Electronic throughout 0 to 95° rotation
Operating range Y	2 to 10 VDC, 4 to 20 mA
Input impedance	100 kΩ (0.1 mA), 500Ω
Feedback output U	2 to 10 VDC, 0.5 mA max
Angle of rotation	mechanically limited to 95°
Torque	min 266 in-lb [30 Nm]
Direction of rotation	reversible with switch A/B A = CW with an increase in voltage B = CCW with an increase in voltage
Position indication	0 to 1 and reversible indicator
Running time	135 sec. independent of load
Humidity	5 to 95% RH, non-condensing
Ambient temperature	-22°F to +122°F [-30°C to +50°C]
Storage temperature	-40°F to +176°F [-40°C to +80°C]
Housing	NEMA type 2
Housing rating	UL94V-0 (flammability rating)
Agency listings	UL 873 listed, CSA C22.2 No.24 certified, CE
Noise level	max. 45 dB (A)
Servicing	maintenance free
Quality standard	ISO 9001
Weight	4.2 lbs (1.9 kg.)

Dimensions (All numbers in brackets are metric.)

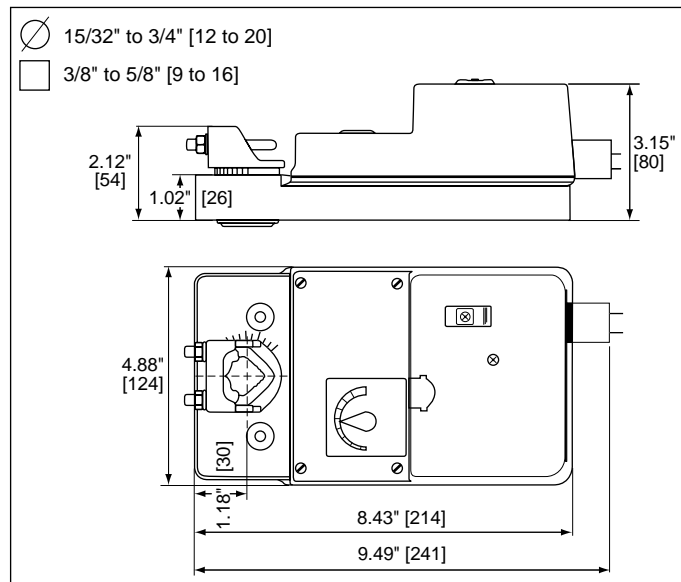

F20358 / 5 4 3 2 1 -01/04-10M-IG-Subject to change. © Belimo Aircontrols (USA), Inc.

Proportional damper actuator, non-spring return, direct coupled,
24 V for 2 to 10 VDC and 4 to 20 mA control signal.

Accessories

IRM-100	Input scaling module
KH8	Universal crankarm
KG10	Ball Joint
NSV24	Battery back-up module
P...	Feedback potentiometer
PTA-250	Pulse width modulation interface
SGA24	Min. and/or manual positioner in NEMA 4 housing
SGF24	Min. and/or man. positioner for flush panel mount
S1,S2	Auxiliary switch
Tool-01	10mm wrench
ZAD24	Digital position indication
ZDB-GM	Angle of rotation limiter (Series 2)
ZG-H2	Actuator operator handle
ZG-GM2	Crankarm adaptor kit
ZG-R01	500Ω resistor for 4 to 20 mA
ZG-100	Universal mounting bracket
ZG-101	Universal mounting bracket
ZG-102	Multiple actuator mounting bracket
ZG-103	Universal mounting bracket
ZG-104	Universal mounting bracket
ZS-100	Weather shield (metal)
ZS-150	Weather shield (polycarbonate)
ZS-260	Explosion-proof housing
ZS-300	NEMA 4X housing

NOTE: When using GM24-SR US actuators, use only the accessories listed on this page.

GM24-SR US - Typical Specification:

Control damper actuators shall be electronic direct coupled type which require no crankarm and linkage. Actuators shall be UL listed and CSA certified, have a 2 year warranty, and be manufactured under ISO 9001 International Quality Control Standards. Actuators shall have reversing switch and gear disengagement button on the cover. Actuators shall use a brushless DC motor and be protected from overload at all angles of rotation. Run time shall be constant and independent of torque. The actuator must provide proportional damper control in response to a 2 to 10 VDC or, with the addition of a 500Ω resistor, a 4 to 20 mA control input from an electronic controller or positioner. A 2 to 10 VDC feedback signal shall be provided for position indication or master-slave applications. Actuators shall be as manufactured by Belimo.

Multiple actuators mounted to shaft	
Model	Maximum quantity per shaft
GM24 US	2
GM24-SR US	2

Wiring diagrams

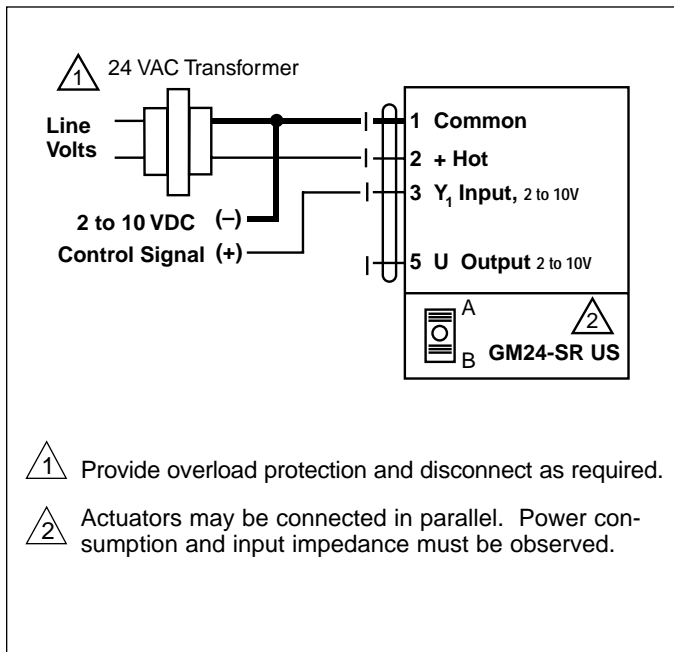

0 to 10 VDC control of GM24-SR US

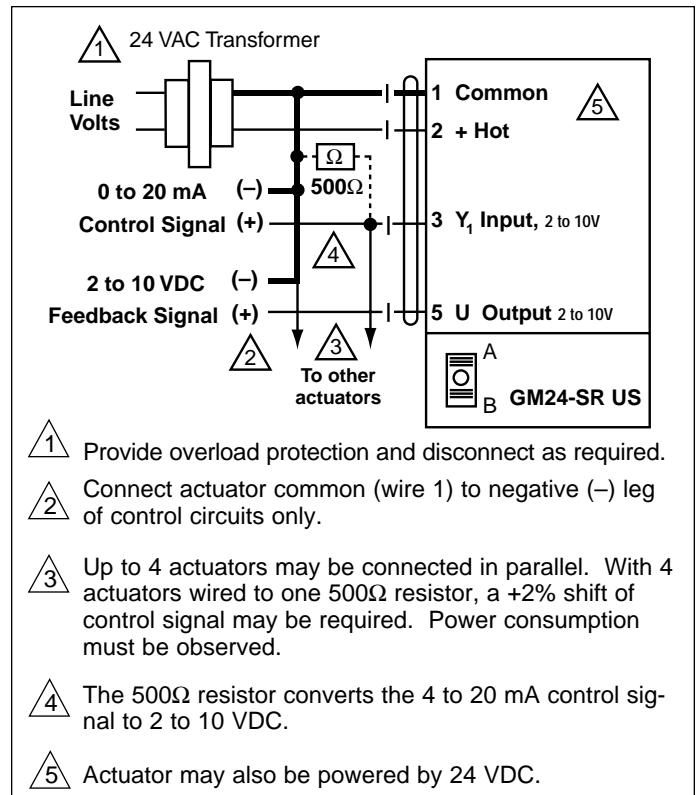

4 to 20 mA control of GM24-SR US with 2 to 10 VDC feedback output.

Installation Instructions

Quick-Mount Visual Instructions for Mechanical Installation

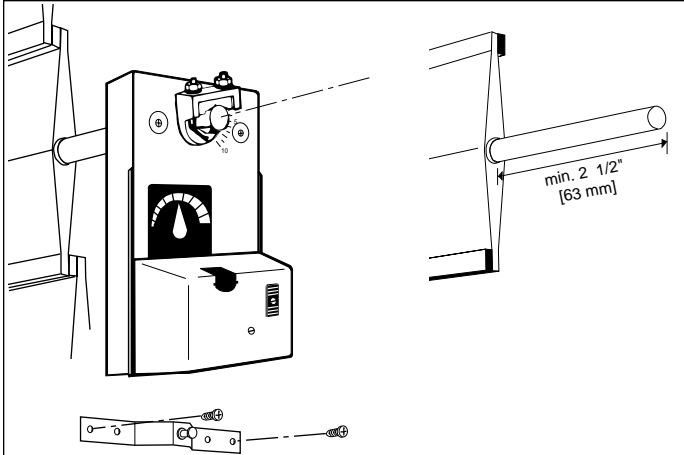

Installation instruction for damper shafts with a minimum length of 2 1/2 inch [63 mm] for GM series actuators

1. Move the damper to closed position.
2. Position actuator onto damper shaft.
3. Hand tighten nuts on V-clamp.
4. If necessary, bend anti-rotation strap at both ends to fit between damper frame.
5. Fix anti-rotation strap to damper frame.
6. Disengage gears with manual release button on casing.
7. Turn motor clamp back to 5° before closed position and allow gears to re-engage.
8. Align the actuator at 90° to the damper shaft and verify that the damper is still in the fully closed position.
9. Tighten nuts on the V-clamp.

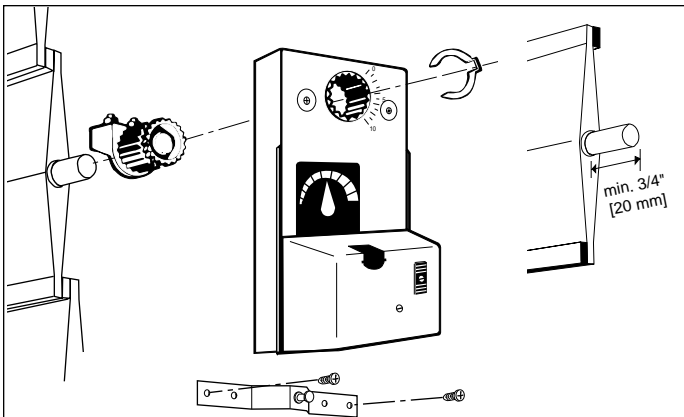

Installation instruction for damper shafts with a minimum length of 3/4 inch [20 mm] or bridging of damper frame

1. Disengage gears with manual release button on casing (Manual operation).
2. Turn actuator clamp back to 5° before closed position and allow gears to re-engage.
3. Pull out universal clamp after removing retaining clip.
4. Fix universal clamp onto damper shaft.
5. Move damper into closed position.
6. Position actuator onto universal clamp.
7. Refit retaining clip.
8. If necessary bend or cut anti-rotation strap on either side to fit the damper frame.
9. Slide the stud of the anti-rotation strap into slot on actuator base and fix it with screws to damper frame.

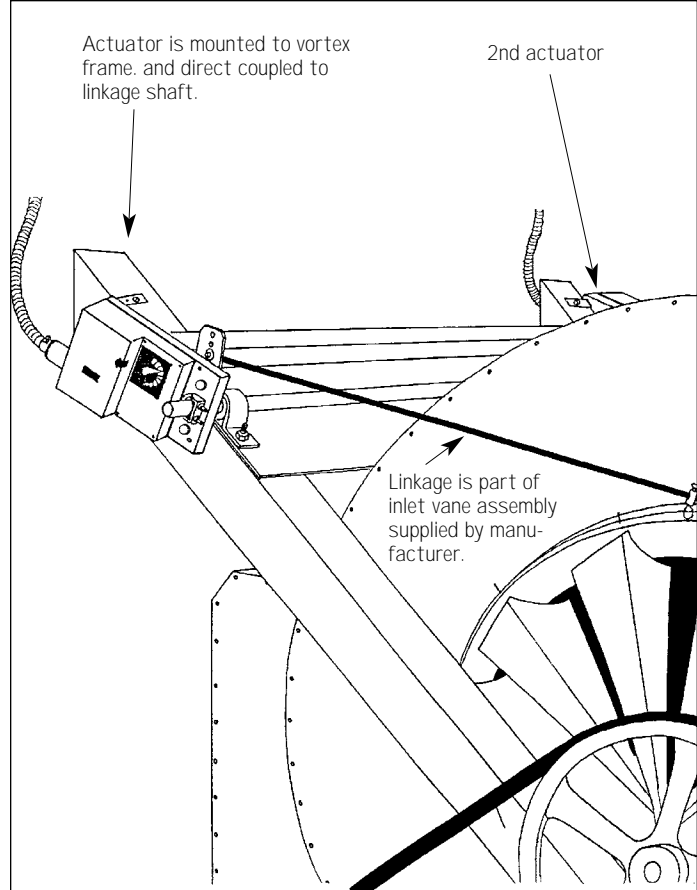

Installation instruction for mounting GM actuators on inlet guide vanes.

1. Rotate vortex jackshaft fully counterclockwise.
2. Depress manual release button on actuator and rotate universal clamp fully counterclockwise.
3. Position the actuator on the jackshaft so that the actuator is in a position to mount to the anti-rotation strap.
4. Position and mount the anti-rotation strap to the vortex frame so that the mounting stud is one-sixteenth inch from the bottom of the mounting slot of the actuator.
5. Verify that rotation of the actuator is correct for full operation of the vortex blades. Adjust linkage if necessary. Fully tighten the V-bolt nuts.
6. If additional torque is required, add second actuator to the other end of the shaft assembly.

Determining Torque Loading and Actuator Sizing

Damper torque loadings, used in selecting the correct size actuator, should be provided by the damper manufacturer. If this information is not available, the following general selection guidelines can be used.

Damper Type	Torque Loading
Opposed blade, without edge seals, for non-tight close-off applications	3 in-lb/sq. ft.
Parallel blade, without edge seals, for non-tight close-off applications	4 in-lb/sq. ft.
Opposed blade, with edge seals, for tight close-off applications	5 in-lb/sq. ft.
Parallel blade, with edge seals, for tight close-off applications	7 in-lb/sq. ft.

The above torque loadings will work for most applications under 2 in. w.g. static pressure or 1000 FPM face velocity. For applications between this criteria and 3 in. w.g. or 2500 FPM, the torque loading should be increased by a multiplier of 1.5. If the application calls for higher criteria up to 4 in. w.g. or 3000 FPM, use a multiplier of 2.0.

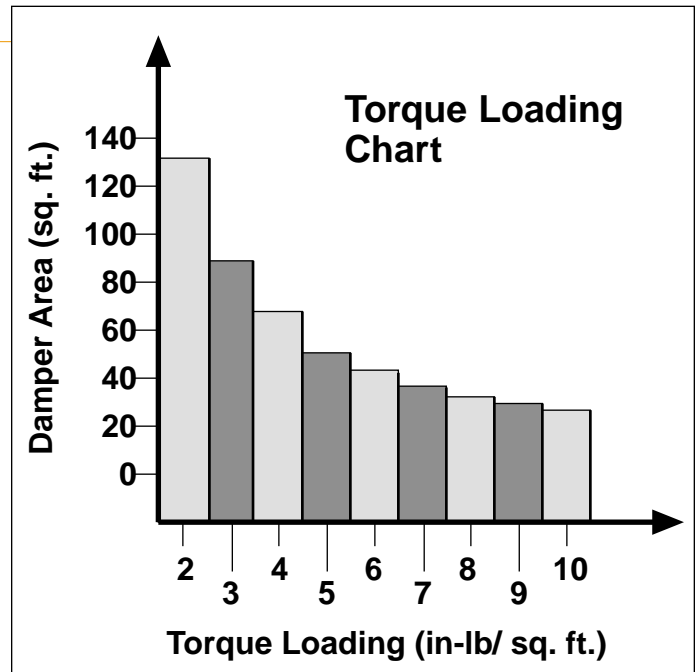

General Information

Preliminary steps

1. Belimo actuators should be mounted indoors in a dry, relatively clean environment free from corrosive fumes. If the actuator is mounted outdoors, a protective enclosure must be used to shield the actuator.
2. For new construction work, **order dampers with extended shafts**. Instruct the installing contractor to allow space for mounting the Belimo actuator on the shaft.

For replacement of existing gear train actuators, there are two options:

- A. From a performance standpoint, it is best to mount the actuator directly onto the damper shaft.
- B. If the damper shaft is not accessible, mount the GM24- . . actuator with a ZG-GM2 crankarm kit, and a mounting bracket (ZG-100, ZG-101, ZG-103, ZG-104)

Standard Mounting

1. Slip the actuator's universal clamp over the damper shaft. Make sure that the bottom of the actuator (metal side) is toward the duct and the controls on the cover are accessible. Place the actuator in the desired mounting position.
2. Turn the damper shaft until the blades are fully closed.
3. Hand tighten the two nuts on the GM24 . . universal clamp.
4. Slide the stud of the anti-rotation bracket into the slot in the bottom of the actuator. Bend the strap as needed to support the rear of the actuator.
5. Fasten the strap to the duct with two screws. We recommend No. 8 self tapping sheet metal screws.
6. Loosen the two nuts on the universal clamp. Disengage the actuator gear train by pressing the "manual override button" (half round black button). Keeping the gears disengaged, and the damper fully closed, rotate the clamp until it is about 5° from the closed position.
7. Tighten the two nuts on the clamp with a 10 mm wrench (Belimo Tool-01). Use 9 to 11 ft-lb of torque.

The damper is now fully closed but the actuator is 5° from fully closed. This is called "pre-loading" the actuator. When the actuator is powered and sent to the closed position: it will put its full torque on the shaft compressing the edge and blade seals. This ensures that the damper will meet its leakage rating. The actuator is electronically protected from overload and will not be damaged.

Manual override

The Belimo GM24 . . actuators have a black, half round "manual override button" located on the top of the housing. Press this button and the gear train is disengaged so the damper shaft can be moved manually. Release the button and the gear train is re-engaged.

Testing the installation without power

1. Disengage the gear train with the manual override button and move the shaft from closed to open to closed. Ensure that there is no binding and that the damper goes fully open and closes with 5° of actuator stroke left.
2. Correct any problems and retest.

Multiple Actuator Mounting

If more torque is required than one GM can provide, a second actuator may be installed on the same shaft. See page 78 for wiring details.

General Wiring

General Wiring Instructions

WARNING The wiring technician must be trained and experienced with electronic circuits. Disconnect power supply before attempting any wiring connections or changes. Make all connections in accordance with wiring diagrams and follow all applicable local and national codes. Provide disconnect and overload protection as required. Use copper, twisted pair, conductors only. If using electrical conduit, the attachment to the actuator must be made with flexible conduit.

Always read the controller manufacturer's installation literature carefully before making any connections. Follow all instructions in this literature. If you have any questions, contact the controller manufacturer and/or Belimo.

Transformer(s)

The GM24... actuators requires a 24 VAC class 2 transformer and draws a maximum of 6 VA for the GM24 US and 7VA for the GM24-SR US. The actuator enclosure cannot be opened in the field, there are no parts or components to be replaced or repaired.

- EMC directive: 89/336/EEC
- Software class A: Mode of operation type 1
- Low voltage directive: 73/23/EEC

CAUTION: It is good practice to power electronic or digital controllers from a separate power transformer than that used for actuators or other end devices. The power supply design in our actuators and other end devices use half wave rectification. Some controllers use full wave rectification. When these two different types of power supplies are connected to the same power transformer and the DC commons are connected together, a short circuit is created across one of the diodes in the full wave power supply, damaging the controller. Only use a single power transformer to power the controller and actuator if you know the controller power supply uses half wave rectification.

Multiple actuators, one transformer

Multiple actuators may be powered from one transformer provided the subsequent rules are followed:

1. The TOTAL current draw of the actuators (VA rating) is less than or equal to the rating of the transformer.
2. Polarity on the secondary of the transformer is strictly followed. *This means that all No. 1 wires from all actuators are connected to the common leg on the transformer and all No 2 wires from all actuators are connected to the hotleg. Mixing wire No. 1 & 2 on one leg of the transformer will result in erratic operation or failure of the actuator and or controls.*

Multiple actuators, multiple transformers

Multiple actuators positioned by the same control signal may be powered from multiple transformers provided the subsequent rules are followed:

1. The transformers are properly sized.
2. All No. 1 wires from all actuators are tied together and tied to the negative leg of the control signal. See wiring diagram on page 16.

Wire length for GM... actuators

Keep power wire runs below the limits listed in Fig. 1 or 2. If more than one actuator is powered from the same wire run, divide the allowable wire length by the number of actuators to determine the maximum run to any single actuator.

Example for GM24-SR US: 3 actuators, 16 Ga wire

$$500 \text{ Ft} \div 3 \text{ Actuators} = 166 \text{ Ft. Maximum wire run}$$

Maximum wire length:

GM24 US

Wire Size	Max. Feet.	Wire Size	Max. Feet
12 Ga	1500 Ft.	18 Ga	375 Ft.
14 Ga	925 Ft.	20 Ga	200 Ft
16 Ga	550 Ft.	22 Ga	100 Ft

Figure 1

GM24-SR US

Wire Size	Max. Feet.	Wire Size	Max. Feet
12 Ga	1250 Ft.	18 Ga	300 Ft.
14 Ga	800 Ft.	20 Ga	160 Ft
16 Ga	500 Ft.	22 Ga	85 Ft

Figure 2

Wire Type and Wire Installation Tips

For most installations, 18 or 16 Ga. cable works well with the GM24...actuators. Use code approved wire nuts, terminal strips or solderless connectors where wires are joined. It is good practice to run control wires unspliced from the actuator to the controller. If splices are unavoidable, make sure the splice can be reached for possible maintenance. Tape and/or wire tie the splice to reduce the possibility of the splice being inadvertently pulled apart.

The GM24... proportional actuators have a digital circuit that is designed to ignore most unwanted input signals (pickup). In some situations the pickup may be severe enough to cause erratic running of the actuator. For example, a large inductive load (high voltage AC wires, motors, etc.) running near the power or control wiring may cause excessive pickup. To solve this problem, make one or more of the following changes:

1. Run the wire in metallic conduit.
2. Reroute the wiring away from the source of pickup.
3. Use shielded wire (Belden 8760 or equal). **Ground the shield to an earth ground. Do not connect it to the actuator common.**

Reversing switch, "A/B"

The GM... actuators have a reversing switch on the cover labeled "A/B". With the switch in position "A", the GM24-SR US actuator rotates clockwise with an increase in voltage or current. With the switch in Position "B", the actuator rotates counterclockwise with an increase in voltage or current.

The GM24 US, on-off, tri-state actuators when set for switch position "A", rotates clockwise when power is applied to wire #2, and counterclockwise when power is applied to wire #3.

The GM24 US, on-off, tri-state actuators when set for switch position "B", rotates counterclockwise when power is applied to wire #2, and clockwise when power is applied to wire #3.

General Wiring Instructions (continued)

During checkout, the switch position can be temporarily reversed and the actuator will reverse its direction. This allows the technician a fast and easy way to check the actuator operation without having to switch wires or change settings on the thermostat. **When the check-out is complete, make sure the switch is placed back to its original position.**

The Position Indicator can be reversed depending on the desired direction of rotation of the damper.

1. Pull out the white pointer.
2. Turn the position indication card.
3. Replace the white pointer.

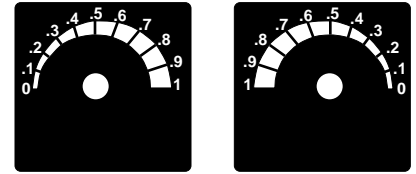

Control Accuracy and Stability

GM24 US Series actuators have built-in brushless DC motors which provide better accuracy and longer service life.

The GM24-SR US is designed with a unique non-symmetrical deadband. The actuator follows an increasing or decreasing control signal with a 40 mV resolution. If the signal changes in the opposite direction, the actuator will not respond until the control signal changes by 200 mV. This allows the GM24-SR US to track even the slightest deviation very accurately, yet allowing the actuator to “wait” for a much larger change in control signal due to control signal instability.

Actuator responds to a 40 mV signal when not changing direction from stop position.

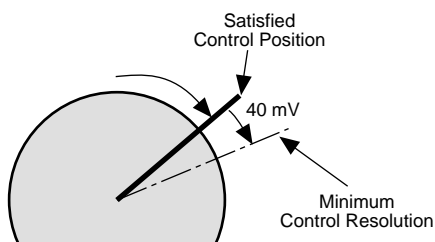

Actuator responds to a 200 mV signal when reversing direction from stop position.

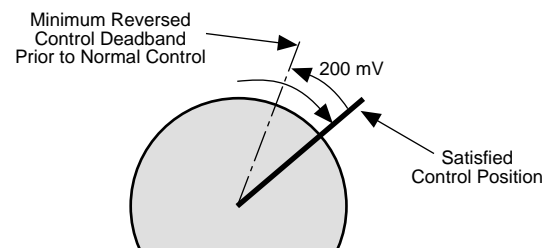

Electrical Operation

General

The GM Series actuators utilize brushless DC motor technology. The GM uses this motor in conjunction with an Application Specific Integrated Circuit (ASIC). The ASIC monitors and controls the actuator’s rotation and a digital rotation sensing function to prevent damage to the actuator.

Brushless DC motor operation

Belimo’s brushless DC motor spins by reversing the poles of stationary electromagnets housed inside of a rotating permanent magnet. The electromagnetic poles are switched by a special ASIC circuit developed by Belimo. Unlike the conventional DC motor, there are no brushes to wear or commutators to foul.

Overload protection

The GM Series actuators are protected from overload at all angles of rotation. The ASIC circuit constantly monitors the rotation of the DC motor inside the actuator and stops the pulses to the motor when it senses a stall condition. The DC motor remains energized and produces full rated torque to the load. This helps ensure that dampers are fully closed and that edge and blade seals are always properly compressed.

Rotation Limitation GM Series

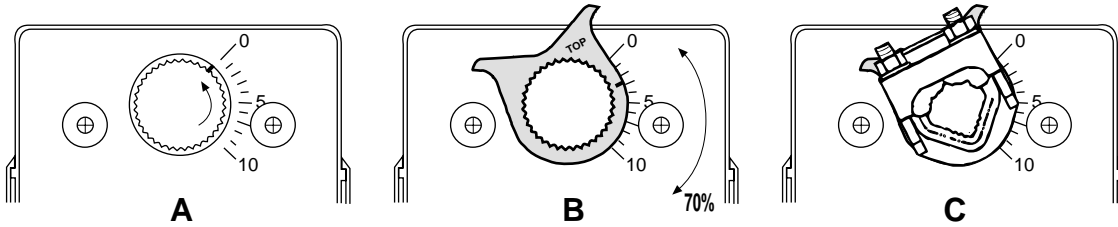

1. Disengage gears with manual release button on casing (Manual operation).
2. Turn actuator clamp back to the "0" position for CW operation when power is applied. "10" position for CCW operation
3. Pull out clamp after removing retaining clip. Note position indicator is at 0. (A)
4. Locate the angle of rotation limiter (ZDB-GM) on the actua-

tor so that its mark sign lines up with the degree graduation on the actuator face which corresponds with the required rotation. (Every division represents approximately 10% of the angle of rotation). (B)
 Example: 3 divisions away from the end position means: $100\% - (3 \text{ divisions} \times 10\%) = 70\%$
 5. Position clamp onto actuator and refit retaining clip. (C)

Non-Direct Mounting Methods

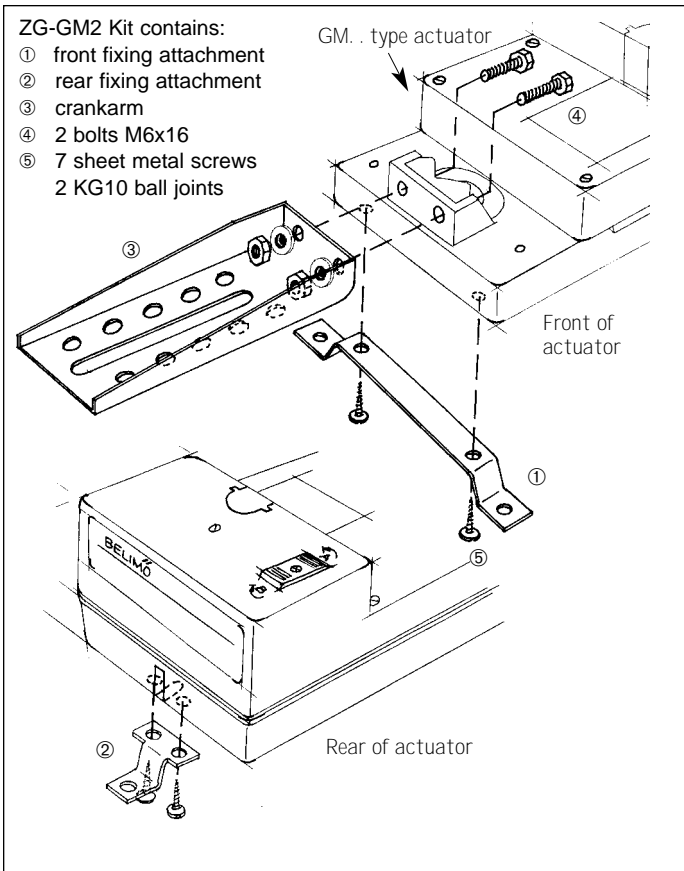

ZG-GM2 Damper linkage kit

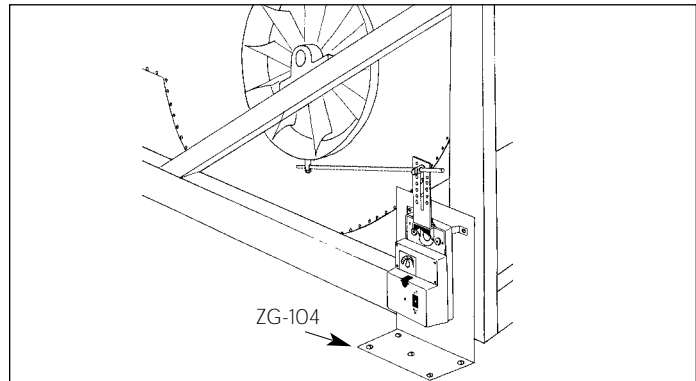

Actuator is mounted to a universal mounting bracket or field-fabricated bracket. Connect to inlet vanes with linkage.

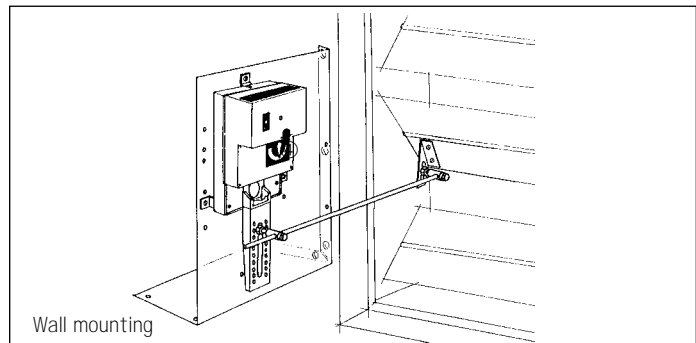

ZG-GM2 with ZG-100 Universal Mounting Bracket, using linkage to operate the damper blade.

GM24-SR US Electrical check-out procedure

Step	Procedure	Expected Response	Gives Expected Response Go To Step...	Does Not Give Expected Response Go To Step...
1.	Control signal is applied to actuator.	Actuator will move to its "Control Signal" position.	Actuator operates properly Step 8	No response at all Step 2 Operation is reversed Step 3 Does not drive toward "Control Signal Position" Step 4
2.	Check power wiring. Correct any problems. See Note 1.	Power supply rating should be \geq the total power requirement of the actuator(s). Minimum voltage of 19.2 VAC or 21.6 VDC.	Power wiring corrected, actuator begins to drive Step 1	Power wiring corrected, actuator still does not drive Step 4
3.	Turn reversing switch to the correct position.	Actuator will move to its "Control Signal" position.	Actuator operates properly. Step 8	Does not drive toward "Control Signal Position" Step 4
4.	Make sure the control signal positive (+) is connected to Wire No 3 and control signal negative (-) is connected to wire No. 1. Most control problems are caused by reversing these two wires. Verify that the reversing switch is all the way CCW or CW.	Drives to "Control Signal" position	Actuator operates properly. Step 8	Step 5
5.	Check input signal with a digital volt meter (DVM). Make sure the input is within the range of the actuator. For GM24-SR US this is 0 to 10 VDC or 0 to 20 mA. Note: The input signal must be above the 2 VDC or 4 mA to have the actuator move.	Input voltage or current should be $\pm 1\%$ of what controller's adjustment or programming indicate.	Controller output (actuator input) is correct. Input Polarity Correct. Step 6	Reprogram, adjust repair or replace controller as needed. Step 1
6.	Use the manual override button to move the damper by hand from fully closed to fully open.	Damper will go from fully closed to fully open.	Damper moves properly Step 7	Find cause of damper jam and repair. Step 1
7.	Check damper torque requirement.	Torque requirement is \leq actuator's minimum torque.	Defective Actuator. Replace Actuator - See Note 2	Recalculate actuator requirement and correct installation.
8.	Actuator works properly. Test controller by following controller manufacturer's instructions.			

F20358 / 5 4 3 2 1 -01/04-10M-IG-Subject to change. © Belimo Aircontrols (USA), Inc.

GM

Note 1 Check that the transformer(s) are sized properly.

- If a common transformer is used, make sure that polarity is observed on the secondary. This means connect all No. 1 wires to one leg of the transformer and all No. 2 wires to the other leg of the transformer.
- If multiple transformers are used with one control signal, make sure all No. 1 wires are tied together and tied to control signal negative (-).
- Controllers and actuators must have separate 24 VAC/VDC power sources.

Note 2 If failure occurs within 5 years from original installation date, notify Belimo and give details of the application.