



GREYSTONE ENERGY SYSTEMS INC

HIGH ACCURACY GLASS TEMPERATURE TRANSMITTER HATXGL Series

The high accuracy single point glass temperature transmitter utilizes a precision sensor encapsulated in a 31.75mm L x 9.525mm W x 9.525 mm H (1.25" x .375" x .375") Aluminum probe. Standard wire length is 600 mm (24"). All probes are constructed to provide excellent heat transfer, fast response, and are potted to resist moisture penetration. It is available with a variety of enclosures. A transmitter that provides a high accuracy signal with excellent long term stability, low hysteresis and fast response is available with various ranges.

SPECIFICATION:

Sensor Type	1000 ohm Platinum RTD
Sensor Accuracy.....	RTD Class A: ±0.15°C @ 0°C RTD 1/3 DIN: ±0.1°C @ 0°C RTD 1/10 DIN: ±0.03°C @ 0°C
Probe Sensing Range.....	-20 to 60°C (-4 to 140°F)
Wire Material.....	PVC insulated, parallel bonded, 22 AWG
Wire Length.....	600 mm (24")
Probe Material.....	Aluminum
Probe Dimensions.....	31.75 x 9.525 x 9.525 mm (1.25" x 0.375" x 0.375")
Output Signal.....	4-20 mA current loop, 0-5 Vdc, or 0-10 Vdc (factory configured)
Transmitter Accuracy	±0.125% of span, including linearity
4-20 mA loop power supply.....	15-35 Vdc or 22-32 Vac
Minimum Loop Current.....	2 mA nominal (occurs with shorted sensor)
Maximum Loop Current.....	22.5 mA nominal (occurs with open sensor)
Maximum Loop Load.....	>600 ohms
0-5 Vdc Power Supply.....	10-35 Vdc or 10-32 Vac
0-10 Vdc Power Supply.....	15-35 Vdc or 15-32 Vac
Maximum Current (Voltage).....	5 mA nominal
Maximum Output (Voltage).....	limited to <5.5 Vdc for 0-5 Vdc, <10.5 for 0-10 Vdc
Input Voltage Effect.....	Negligible over specified operating range
Protection Circuitry.....	Reverse voltage protected and output limited
Ambient Operating Range.....	0 to 50°C (32 to 122°F), 0 to 95 %RH non-condensing
Enclosure.....	ABS - UL94-V0, IP65 (NEMA4X) E - includes thread adapter (1/2" NPT to M16), and cable gland fitting
Wiring Connections.....	Screw terminal block (14 to 22 AWG)
Country of Origin.....	Canada

*This product is factory calibrated and any field adjustment will void the warranty.

TYPICAL INSTALLATION:

For complete installation and wiring details, please refer to the product installation instructions.

Find a suitable location on an exterior window where both the probe and enclosure can be mounted. On one side apply epoxy compound and press firmly against the glass. Hold in place until the epoxy has set.

Enclosure provides mounting tabs for ease of installation.

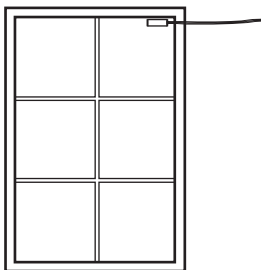

PART NUMBER SELECTED

PRODUCT SELECTION INFORMATION:

MODEL	Product Description
HATXGL	High Accuracy Glass Temperature Transmitter

CODE	Enclosure
A	ABS, with hinged & gasketed cover
E	Same as A, with thread adapter & cable gland fitting

CODE	Sensor
18	1000 Ω, Platinum, 2 wire, IEC 751, 385 Alpha, thin film Class A
48	1000 Ω, Platinum, 2 wire, IEC 751, 385 Alpha, thin film 1/3 DIN
22	1000 Ω, Platinum, 2 wire IEC 751, 385 Alpha, thin film, 1/10 DIN
41	1000 Ω, Platinum, 3 wire, IEC 751, 385 Alpha, thin film, Class A
49	1000 Ω, Platinum, 3 wire, IEC 751, 385 Alpha, thin film, 1/3 DIN
50	1000 Ω, Platinum, 3 wire IEC 751, 385 Alpha, thin film, 1/10 DIN

CODE	Output
A	4-20mA
D	0-5 Vdc
E	0-10 Vdc

CODE	Scaled Range
001	0 to 35°C (32 to 95°F)
002	0 to 50°C (32 to 122°F)
003	0 to 100°C (32 to 212°F)
*	Custom Ranges Available

Greystone Energy Systems, Inc. reserves the right to make design modifications without prior notice.

DIMENSIONS:

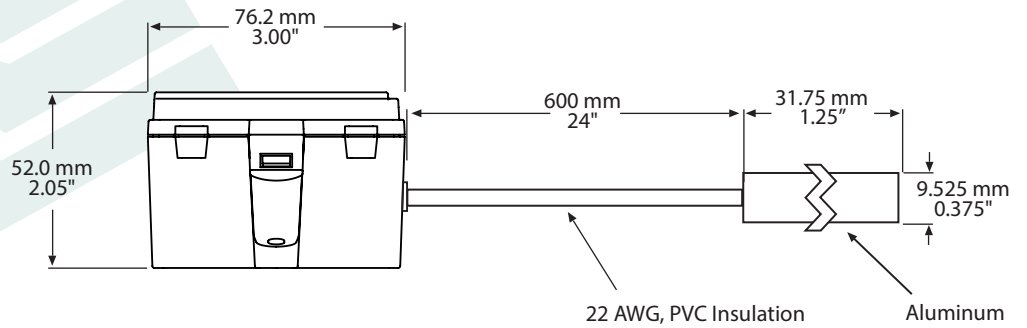
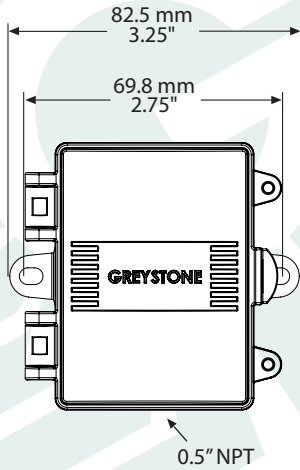

Included with E style enclosure

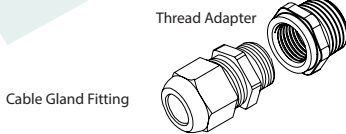

GREYSTONE

ENERGY SYSTEMS INC

Greystone Energy Systems, Inc.
150 English Drive, Moncton,
New Brunswick, Canada E1E 4G7
(506) 853-3057 Fax: (506) 853-6014
North America: 1-800-561-5611
e-mail: mail@greystoneenergy.com
www.greystoneenergy.com

RoHS
COMPLIANT



Greystone Energy Systems Inc. is one of North America's largest ISO registered manufacturers of HVAC/R sensors and transmitters for Building Automation Management Systems.

We have conscientiously established a worldwide reputation as an industry leader by maintaining leading-edge design technology, prompt technical support, and a commitment to on-time deliveries. We take pride in our Quality Management System which is ISO 9001 certified, assuring our customers of consistent product reliability.

GREYSTONE HAS AN ISO 9001 REGISTERED QUALITY SYSTEM