

VAV-Universal, ready-to-connect rotary actuator fail-safe for VAV and CAV units in technical building installations

- Torque motor 4 Nm
- Nominal voltage AC/DC 24 V
- Control communicative PP

Technical data

Electrical data	Nominal voltage	AC/DC 24 V
	Nominal voltage frequency	50/60 Hz
	Nominal voltage range	AC 19.2...28.8 V / DC 21.6...28.8 V
	Power consumption in operation	2.5 W
	Power consumption in rest position	1 W
	Power consumption for wire sizing	5 VA
	Connection supply / control	Cable 0.5 m with VST connector
	Parallel operation	No
Functional data	Torque motor	4 Nm
	Torque fail-safe	4 Nm
	Direction of motion variable	At VRU-...BAC with Belimo Assistant App
	Manual override	No
	Running time motor	120 s / 90°
	Running time fail-safe	<20 s / 90°
	Adaptation setting range variable	Triggering at VRU-...BAC, by pressing the Adaption button or with Belimo Assistant App
	Sound power level, motor	40 dB(A)
	Mechanical interface	Universal shaft clamp 8...16 mm
	Position indication	Mechanical
	Service life	Min. 60'000 fail-safe positions
Safety data	Protection class IEC/EN	III Safety Extra-Low Voltage (SELV)
	Degree of protection IEC/EN	IP54
	EMC	CE according to 2014/30/EU
	Certification IEC/EN	IEC/EN 60730-1 and IEC/EN 60730-2-14
	Mode of operation	Type 1.AA
	Rated impulse voltage supply / control	0.8 kV
	Control pollution degree	3
	Ambient temperature	-30...50°C
	Storage temperature	-40...80°C
	Ambient humidity	Max. 95% r.H., non-condensing
	Servicing	maintenance-free
Weight	Weight	1.9 kg

Safety notes



- The device must not be used outside the specified field of application, especially not in aircraft or in any other airborne means of transport.
- Outdoor application: only possible in case that no (sea) water, snow, ice, insulation or aggressive gases interfere directly with the device and that it is ensured that the ambient conditions remain within the thresholds according to the data sheet at any time.
- Only authorised specialists may carry out installation. All applicable legal or institutional installation regulations must be complied during installation.
- The device may only be opened at the manufacturer's site. It does not contain any parts that can be replaced or repaired by the user.
- Cables must not be removed from the device.
- Self adaption is necessary when the system is commissioned and after each adjustment of the angle of rotation (press the adaption push-button once).
- To calculate the torque required, the specifications supplied by the damper manufacturers concerning the cross-section, the design, the installation site and the ventilation conditions must be observed.
- The device contains electrical and electronic components and must not be disposed of as household refuse. All locally valid regulations and requirements must be observed.

Accessories

Electrical accessories	Description	Type
	VAV-Universal - Volumetric flow / strand pressure controller	VRU-D3-BAC
	VAV-Universal - Volumetric flow / strand pressure controller	VRU-M1-BAC
	VAV-Universal - room pressure controller	VRU-M1R-BAC

Electrical installation

Wiring diagrams

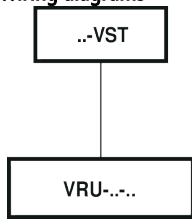

Plug-in connection with pre-assembled cable-plug unit

Installation notes

Installation situation Remove actuator cable:
 The connecting cable of the VST damper actuator can be removed from the VRU controller using a screwdriver (size 0...3) as shown in the illustration.

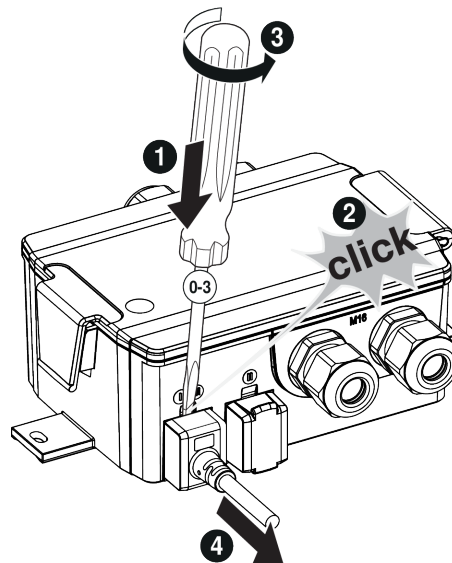

Dimensions

Dimensional drawings

