

- Torque motor 4 Nm
- Nominal voltage AC/DC 24 V
- Control modulating, communicative 2...10 V variable
- Position feedback 2...10 V variable
- Conversion of sensor signals
- Deenergised open (NO)
- Communication via Belimo MP-Bus



Technical data

Electrical data	Nominal voltage	AC/DC 24 V
	Nominal voltage frequency	50/60 Hz
	Nominal voltage range	AC 19.2...28.8 V / DC 21.6...28.8 V
	Power consumption in operation	6 W
	Power consumption in rest position	2.5 W
	Power consumption for wire sizing	10 VA
	Connection supply / control	Cable 1 m, 4 x 0.75 mm ²
	Parallel operation	Yes (note the performance data)
Functional data	Torque motor	4 Nm
	Torque fail-safe	4 Nm
	Communicative control	MP-Bus
	Operating range Y	2...10 V
	Input Impedance	100 kΩ
	Operating range Y variable	Start point 0.5...30 V End point 2.5...32 V
	Options positioning signal	Open/close 3-point (AC only) Modulating (DC 0...32 V)
	Position feedback U	2...10 V
	Position feedback U note	Max. 0.5 mA
	Position feedback U variable	Start point 0.5...8 V End point 2.5...10 V
	Position accuracy	±5%
	Direction of motion motor	Y = 0 (0 V = A – AB = 0%)
	Direction of motion fail-safe	Deenergised NO, valve open (A – AB = 100%)
	Manual override	No
	Running time motor	75 s / 90°
	Running time motor variable	75...300 s
	Running time fail-safe	<20 s / 90°
	Running time fail-safe note	@ -20...50°C / <60 s @ -30°C
	Adaptation setting range	manual (automatic on first power-up)
	Adaptation setting range variable	No action Adaptation when switched on Adaptation after using the rotation switch
	Override control	MAX (maximum position) = 100% MIN (minimum position) = 0% ZS (intermediate position, AC only) = 50%
Override control variable	MAX = (MIN + 33%)...100% MIN = 0%...(MAX – 33%) ZS = MIN...MAX	
Sound power level, motor	45 dB(A)	

	Position indication	Mechanical
	Service life	Min. 60'000 fail-safe positions
Safety data	Protection class IEC/EN	III Safety Extra-Low Voltage (SELV)
	Degree of protection IEC/EN	IP54
	EMC	CE according to 2014/30/EU
	Certification IEC/EN	IEC/EN 60730-1 and IEC/EN 60730-2-14
	Mode of operation	Type 1
	Rated impulse voltage supply / control	0.8 kV
	Control pollution degree	3
	Ambient temperature	-30...50°C
	Storage temperature	-40...80°C
	Ambient humidity	Max. 95% r.H., non-condensing
	Servicing	maintenance-free
Weight	Weight	1.5 kg

Safety notes

- This device has been designed for use in stationary heating, ventilation and air-conditioning systems and must not be used outside the specified field of application, especially in aircraft or in any other airborne means of transport.
- Outdoor application: only possible in case that no (sea) water, snow, ice, insulation or aggressive gases interfere directly with the device and that it is ensured that the ambient conditions remain within the thresholds according to the data sheet at any time.
- Only authorised specialists may carry out installation. All applicable legal or institutional installation regulations must be complied during installation.
- The device may only be opened at the manufacturer's site. It does not contain any parts that can be replaced or repaired by the user.
- Cables must not be removed from the device.
- The device contains electrical and electronic components and must not be disposed of as household refuse. All locally valid regulations and requirements must be observed.

Product features

Mode of operation	<p>Conventional operation:</p> <p>The actuator is connected with a standard modulating signal 0...10 V. The actuator moves the valve to the operating position at the same time as tensioning the return spring. The valve is turned back to the fail-safe position by spring force when the supply voltage is interrupted.</p> <p>Operation on Bus:</p> <p>The actuator receives its digital positioning signal from the higher level controller via the MP-Bus and drives to the position defined. Connection U serves as communication interface and does not supply an analogue measuring voltage.</p>
Converter for sensors	<p>Connection option for a sensor (passive or active sensor or switching contact). The MP actuator serves as an analogue/digital converter for the transmission of the sensor signal via MP-Bus to the higher level system.</p>
Configurable actuators	<p>The factory settings cover the most common applications. Single parameters can be modified with the Belimo Service Tools MFT-P or ZTH EU.</p>
Simple direct mounting	<p>Simple direct mounting on the ball valve with only one screw. The mounting orientation in relation to the ball valve can be selected in 90° steps.</p>
High functional reliability	<p>The actuator is overload protected, requires no limit switches and automatically stops when the end stop is reached.</p>
Home position	<p>The first time the supply voltage is switched on, i.e. at the time of commissioning, the actuator carries out an adaption, which is when the operating range and position feedback adjust themselves to the mechanical setting range.</p> <p>The actuator then moves into the position defined by the positioning signal.</p>

Factory setting: R (counter-clockwise rotation).

Adaptation and synchronisation An adaption can be triggered manually by switching the direction of rotation switch from the left to the right twice within 5s or with the PC-Tool. Both mechanical end stops are detected during the adaption (entire setting range). Automatic synchronisation after actuating the direction of rotation switch once is programmed. The synchronisation is in the home position (0%).

A range of settings can be adapted using the PC-Tool (see MFT-P documentation)

Accessories

Gateways	Description	Type
	Gateway MP zu BACnet MS/TP	UK24BAC
	Gateway MP to KNX	UK24EIB
	Gateway MP to Modbus RTU	UK24MOD
Electrical accessories	Description	Type
	Connection cable 5 m, A: RJ11 6/4 ZTH EU, B: 6-pin for connection to service socket	EXT-WR-FP20-MP
	Connection cable 5 m, A: RJ11 6/4 ZTH EU, B: free wire end for connection to MP/PP terminal	ZK1-GEN ZK2-GEN
	MP-Bus power supply for MP actuators	ZN230-24MP
Service tools	Description	Type
	Adapter for Service-Tool ZTH	MFT-C
	Belimo PC-Tool, Software for adjustments and diagnostics	MFT-P
	Service Tool, with ZIP-USB function, for parametrisable and communicative Belimo actuators, VAV controller and HVAC performance devices	ZTH EU

Electrical installation



Supply from isolating transformer.
Parallel connection of other actuators possible. Observe the performance data.

Wiring diagrams

AC/DC 24 V, modulating

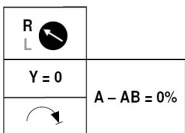
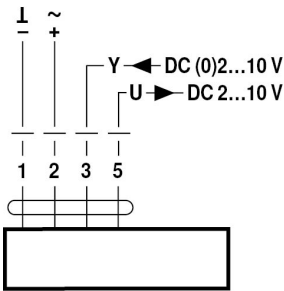

Cable colours:

- 1 = black
- 2 = red
- 3 = white
- 5 = white

Operation on the MP-Bus

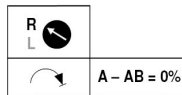
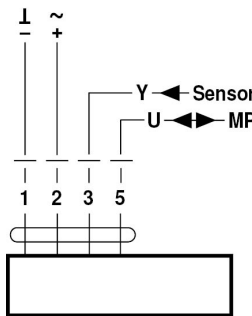

Cable colours:

- 1 = black
- 2 = red
- 3 = white
- 5 = white

Functions when operated on MP-Bus

Connection on the MP-Bus

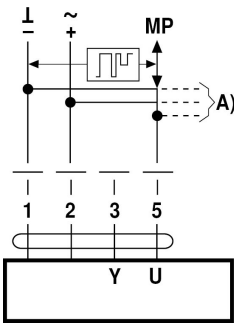

A) additional MP-Bus nodes (max. 8)

MP-Bus Network topology

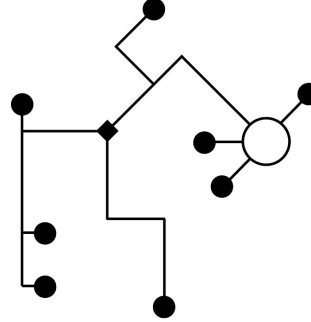

There are no restrictions for the network topology (star, ring, tree or mixed forms are permitted). Supply and communication in one and the same 3-wire cable

- no shielding or twisting necessary
- no terminating resistors required

Connection of active sensors

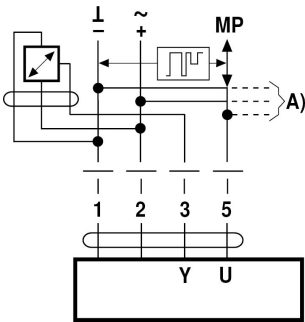

A) additional MP-Bus nodes (max. 8)

- Supply AC/DC 24 V
- Output signal DC 0...10 V (max. DC 0...32 V)
- Resolution 30 mV

Connection of external switching contact

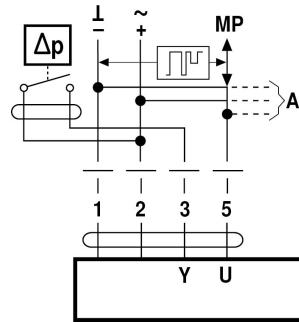

A) additional MP-Bus nodes (max. 8)

- Switching current 16 mA @ 24 V
- Start point of the operating range must be parametrised on the MP actuator as $\geq 0.5 V$

Connection of passive sensors

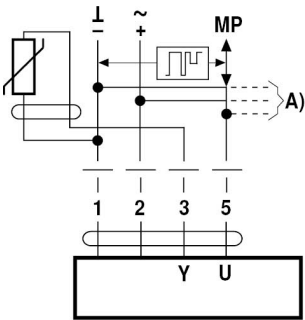

Ni1000	-28...+98 °C	850...1600 Ω^2
PT1000	-35...+155 °C	850...1600 Ω^2
NTC	-10...+160 °C ¹⁾	200 Ω ...60 k Ω ²⁾

A) additional MP-Bus nodes (max. 8)

- 1) Depending on the type
- 2) Resolution 1 Ohm

Functions with basic values (conventional mode)

Override control with AC 24 V with relay contacts

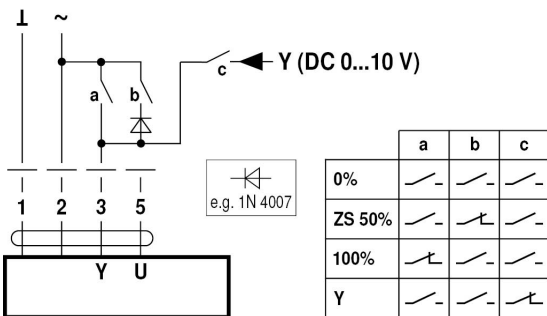

Override control with AC 24 V with rotary switch

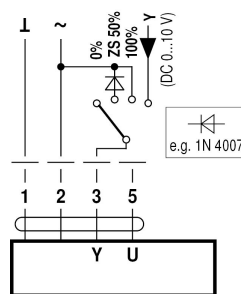

Control remotely 0...100% with positioner SG..

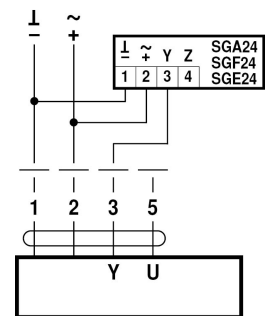

Minimum limit with positioner SG..

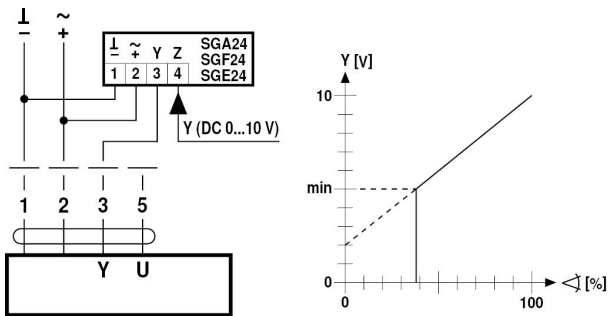

Follow-up control (position-dependent)

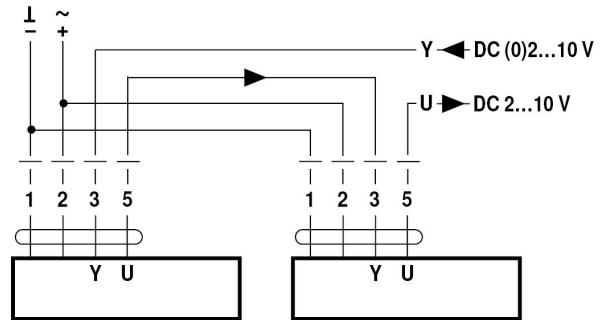

Control with 4...20 mA via external resistor

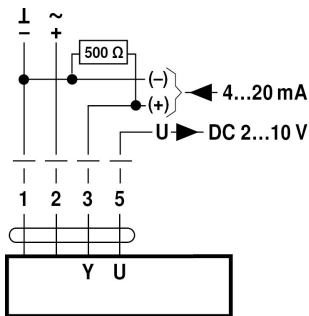

Caution:

The operating range must be set to DC 2...10 V.
The 500 Ω resistor converts the 4...20 mA current signal to a voltage signal DC 2...10 V

Functional check

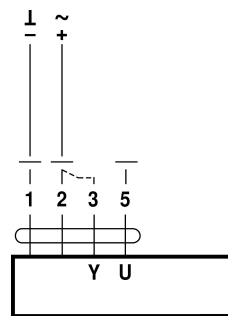

Procedure

1. Connect 24 V to connections 1 and 2
2. Disconnect connection 3:
 - with direction of rotation L: Actuator rotates to the left
 - with direction of rotation R: Actuator rotates to the right
3. Short-circuit connections 2 and 3:
 - Actuator runs in opposite direction

Functions for actuators with specific parameters (Parametrisation necessary)

Override control and limiting with AC 24 V with relay contacts

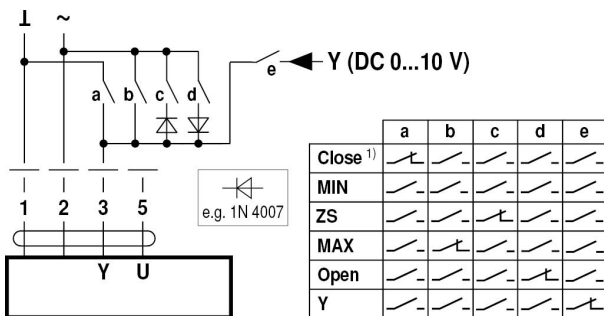

Override control and limiting with AC 24 V with rotary switch

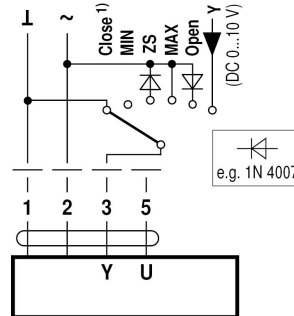

1) **Caution:** This function is only guaranteed if the start point of the operating range is defined as min. 0.5 V.

Control open/close

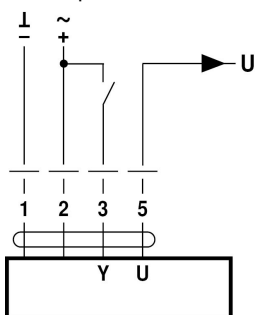

Control 3-point with AC 24 V

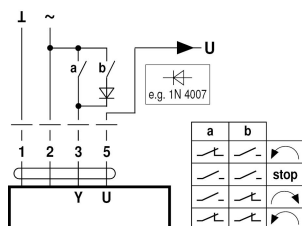

Operating controls and indicators

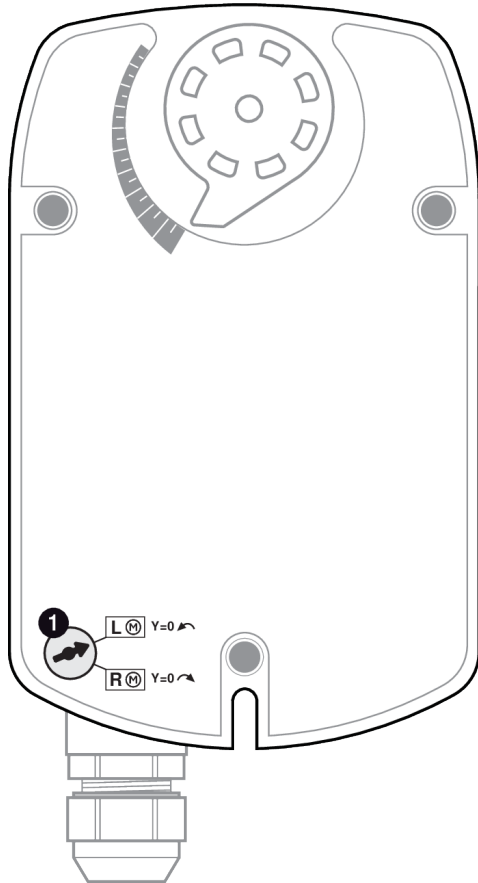

- 1 **MP addressing**
Move direction of rotation switch in opposite position and backwards (within 4 seconds)

Service

Service Tools connection The actuator can be parametrised by ZTH EU via terminal connection. For extended parametrisation the PC tool can be connected.

Connection ZTH EU / PC-Tool

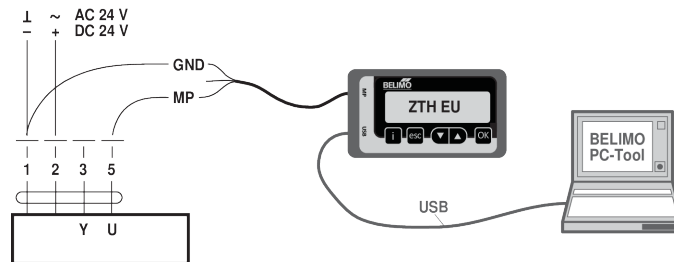

Dimensions

Dimensional drawings

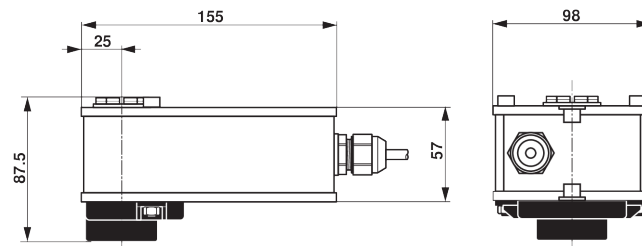

Further documentation

- Overview MP Cooperation Partners
- Tool connections
- Introduction to MP-Bus Technology
- The complete product range for water applications

- Data sheets for ball valves
- Installation instructions for actuators and/or ball valves
- General notes for project planning