

M9106-AGx-2N0x Series Electric Non-spring Return Actuators

The M9106-AGA-2N0x synchronous motor-driven actuators provide floating (3-wire) control and are easily installed on a Variable Air Volume (VAV) box. They may also be installed on a small or medium-sized damper with a round shaft up to 1/2 inch (13 mm) in diameter or a 3/8 inch (10 mm) square shaft.

These compact, non-spring return actuators have a 53 lb-in (6 N·m) running torque in a compact easy-to-install package. The actuators are available with either a nominal 60-second travel time at 60 Hz (72 seconds at 50 Hz) or a nominal 120-second travel time at 60 Hz (144 seconds at 50 Hz) for 90° of rotation.

The M9106-AGS-2N02 Actuator/Transmitter combines an M9106-AGA-2N02 with a prewired DPT-2015 Differential Pressure Transmitter that has a 0 to 1.5 in. W.C. (0 to 374 Pa) differential pressure range.



**Figure 1: M9106-AGS-2N02 Non-spring
Return Actuator**

Features and Benefits	
q 35 dBA Rating	Meets audible requirements for open ceilings
q Synchronous Drive	Provides constant rotation time independent of load
q Direct Shaft Mount with Single-screw Coupler	Simplifies installation and provides 3-point shaft gripping
q Magnetic Clutch	Provides torque protection for the actuator and damper
q Adjustable Rotation Stops	Allow application versatility with 30 to 90° Clockwise (CW) or Counterclockwise (CCW) rotation
q Manual Gear Release	Simplifies setup and field adjustments
q Screw Terminal Connection	Makes wiring easy

Application

IMPORTANT: This device is not designed or intended to be used in or near environments where explosive vapors or gases could be present, or environments where substances corrosive to the device's internal components could be present.

The actuators are used to position balancing, control, round, and zone dampers in typical Heating, Ventilating, and Air Conditioning (HVAC) applications. They are also used to position the blades in a VAV box.

The actuators mount directly to the surface of a VAV box, round damper, or small rectangular damper with a single No. 10 self-drilling sheet metal screw (included). There are no additional linkages or couplers required. Clearly labeled electrical terminals simplify installation. Refer to the damper or VAV box manufacturer's information to select the proper timing for the actuator.

Note: The damper rotation time must be defined at the controller, and the damper point definition must match the rotation time of the actuator.

Operation

IMPORTANT: The M9106-AGx-2N0x Series actuator is intended to control equipment under normal operating conditions. Where failure or malfunction of an M9106-AGx-2N0x actuator could lead to an abnormal operating condition that could cause personal injury or damage to the equipment or other property, other devices (limit or safety controls), or systems (alarm or supervisory) intended to warn of, or protect against, failure or malfunction of an M9106-AGx-2N0x actuator must be incorporated into and maintained as part of the control system.

When combined with a VAV controller, the actuator provides reliable, integrated damper control. See the *M9106-AGx-2N0x Series Electric Non-spring Return Actuators Application Note*, (LIT-2681116) for various configurations with and without the DPT-2015 differential pressure transmitter.

A 24 VAC signal from the controller to the CW or CCW terminal of the actuator causes the motor to rotate in the proper direction, and moves the damper blades open or closed. When the controller stops sending the signal, the actuator remains in place.

Note: To avoid excessive wear or drive time on the motor, use a controller and/or software that provides a time-out function to remove the signal at the end of rotation (stall).

The -2N01 model rotates at a nominal rate of 1.5° per second (90° in 1 minute). The -2N02 models rotate at a nominal rate of 0.75° per second (90° in 2 minutes). Rotation is field adjustable from 30 to 90°. Actual rotation time for actuators using less than 90° rotation must be determined, and that value must be used with the controller software. For example, the travel time for 60° rotation is 40 seconds for the -2N01 model and 80 seconds for a -2N02.

The M9106-AGS-2N02 is prewired with the 20 in. (0.5 m) CBL-2000-1 Wiring Harness and the DPT-2015, which is connected to the airflow pickup device of the VAV box. The DPT-2015 measures differential pressure and generates a proportional 0.5 to 4.5 VDC signal. The voltage signal from the DPT-2015 is read by the VAV controller and converted to airflow in cubic feet per minute (cfm). The wiring harness is used to connect the transmitter and actuator to the VAV Series controller for simplified installation.

Only zero calibration is required, which is performed within the controller. The VAV controller must be provided with the correct "K" factor and VAV box size to perform the calculations. Refer to the *HVAC PRO™ User's Guide, Appendix B: VAV Controller Flow Calculation Constants (LIT-6375185)*.

M9106-AGx-2N0x models are replacements for the one- and two-minute EDA-2040 and ATP-2040 actuators. To replace the EDA-2040 or ATP-2040 originally supplied with an EDA-2040-102 switch kit, use either an:

- M9106-AGx-2N0x actuator with the DMPR-KC010 switch kit (See Table 2.) or
- M9106-AGC-2 actuator: see the *M9106-xGx-2 Series Electric Non-spring Return Actuators Product Bulletin (LIT-2681123)* and *M9106-xGx-2 Series Electric Non-spring Return Actuators Installation Instructions (Part No. 34-636-1085)* for more information.

Dimensions

See Figure 2 for the actuator and differential pressure transmitter dimensions.

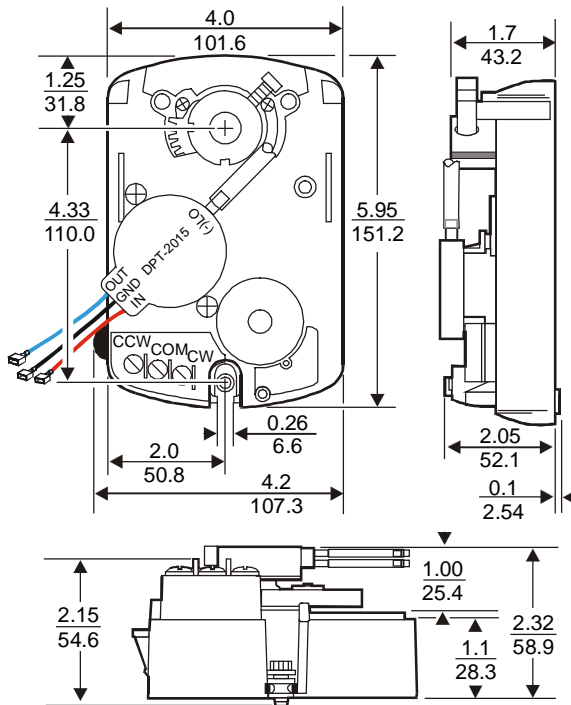

Note: All dimensions are nominal unless otherwise specified.

Figure 2: M9106-AGS-2N02, in. (mm)

Repairs and Replacement

Field repairs must not be made. For a replacement or an accessory, refer to the *Ordering Information* section.

Ordering Information

Contact the nearest Johnson Controls representative, and specify the desired product code number from Table 1 or 2.

Table 1: Actuators

Product Code Number	Description
M9106-AGA-2N01	Electric actuator (1-minute rotation time)
M9106-AGA-2N02	Electric actuator (2-minute rotation time)
M9106-AGS-2N02	Electric actuator (2-minute rotation time) includes the DPT-2015 and CBL-2000-1

Table 2: Accessories

Product Code Number	Description
CBL-2000-1	20 in. (0.5 m) wiring harness, Underwriters Laboratories, Inc.® (UL) accepted for plenum use, supplied with the M9106-AGS-2N02 and may be ordered separately; connects the M9106 and DPT-2015 to the VAV controller
CBL-2000-2	20 in. (0.5 m) plenum-rated wiring harness
CBL-2000-3	72 in. (1.8 m) plenum-rated wiring harness
DPT-2015-0	0 to 1.5 in. W.C. (0 to 375 Pa) differential pressure transmitter supplied with the M9106-AGS-2N02 and may be ordered separately
DMPR-KC003	Blade Pin Extension without Bracket supplied with Johnson Controls® CD-1300 dampers and may be ordered separately for all direct mount applications
DMPR-KC011	Hex head Blade Pin Extension without Bracket
DMPR-KC012	Hex Head Blade Pin Extension with Bracket

Technical Specifications

Product	M9106-AGx-2N0x Series Electric Non-spring Return Actuators	
Power Requirements	M9106-AGA-2N01:	24 VAC (20 to 30 VAC) at 50/60 Hz, 2.5 VA supply, Class 2
	M9106-AGx-2N02:	24 VAC (20 to 30 VAC) at 50/60 Hz, 2.1 VA supply, Class 2
	DPT-2015:	15 VDC (14.5 to 17 VDC) unregulated; 15 mA maximum
Input Signal	M9106-AGx-2N0x:	24 VAC (20 to 30 VAC) at 50/60 Hz
Motor Input Impedance	M9106-AGA-2N01:	200 ohms, nominal
	M9106-AGx-2N02:	250 ohms, nominal
DPT-2015-0	Pressure Range:	0 to 1.5 in. W.C. (0 to 374 Pa)
	Over Pressure Limit:	15 in. W.C. (3.74 kPa)
	Output Voltage:	0.5 to 4.5 VDC with 25,000 ohm minimum load impedance
Mechanical Output	Running Torque:	53 lb·in (6 N·m)
Cycles	100,000 full cycles; 2,500,000 repositions rated at 53 lb·in (6 N·m)	
Audible Noise Rating	35 dBA maximum at 1 m	
Rotation Range	Adjustable from 30 to 90°, CW or CCW	
Rotation Time	M9106-AGA-2N01:	Nominal 60 seconds at 60 Hz and 72 seconds at 50 Hz for 90°
	M9106-AGx-2N02:	Nominal 120 seconds at 60 Hz and 144 seconds at 50 Hz for 90°
Electrical Connection	No. 6-32 screw terminals on the M9106 actuator; 1/4 in. spade terminals on the DPT-2015	
Pressure Connection	6 in. (152 mm) length of silicone tubing with barbed fittings for 1/4 in. (6.35 mm) O.D. tubing	
Enclosure	NEMA1, IP30	
Ambient Operating Conditions	M9106-AGA-2N0x:	32 to 125°F (0 to 52°C); 90% RH maximum, non-condensing
	M9106-AGS-2N02:	32 to 125°F (0 to 52°C); 90% RH maximum, non-condensing 60 to 100°F (16 to 38°C); 90% RH maximum, non-condensing
	For DPT rated accuracy, see <i>DPT-2015 Differential Pressure Transmitter for VAV Box Applications Installation Instructions (Part No. 24-7547-18.)</i>	
Ambient Storage Conditions	-20 to 150°F (-29 to 66°C); 90% RH maximum, non-condensing	
Dimensions (H x W x D)	M9106-AGA-2N01:	5.95 x 4.2 x 2.15 in. (151.2 x 107.3 x 54.6 mm)
	M9106-AGx-2N02:	5.95 x 4.2 x 2.32 in. (151.2 x 107.3 x 58.9 mm) with the DPT-2015
Shipping Weight	M9106-AGA-2N0x:	2.0 lb (0.91 kg)
	M9106-AGS-2N02:	2.2 lb (0.99 kg) with the DPT-2015
Agency Compliance (M9106 Actuator)	UL 873 Listed, File E27734, CCN XAPX CSA C22.2 No. 139 Certified, File LR85083, Class 3221 02 CE Mark, EMC Directive 2004/108/EC	

The performance specifications are nominal and conform to acceptable industry standards. For application at conditions beyond these specifications, consult the local Johnson Controls office. Johnson Controls shall not be liable for damages resulting from misapplication or misuse of its products.



Metasys® and Johnson Controls® are registered trademarks of Johnson Controls. All other marks herein are the marks of their respective owners. © 2017 Johnson Controls.