

Model	Force (N)	Power supply	Description
MVE506	600	24 Vac/Vdc	long yoke, modulating/floating control
MVE510	1000	24 Vac/Vdc	long yoke, modulating/floating control
MVE515	1500	24 Vac/Vdc	long yoke, modulating/floating control
MVE506S	600	24 Vac/Vdc	short yoke, modulating/floating control
MVE510S	1000	24 Vac/Vdc	short yoke, modulating/floating control
MVE515S	1500	24 Vac/Vdc	short yoke, modulating/floating control



### APPLICATION AND USE

The New MVE is a flexible electro-mechanical actuator for the control of two and three way globe valves in:

- Heating and Cooling systems
- Air handling units
- District Heating plants
- Industrial Temperature Control systems.

The MVE can be controlled either by a proportional (modulating) signal or by an increase/decrease (Floating) signal.

It is easy to mount and connect the actuator. Direct mounting is possible to any CONTROLLI flanged valve. Linkage kits are available for CONTROLLI threaded valves as well as for valves of other manufacturers. The Actuator has a fine resolution (500 steps on the full stroke range) for exacting fluid control and it is able to self-calibrate on a different stroke without the need of any user action (this function is dip-switch selectable on the field). The MVE has intelligent behavior and alarm functionality in case of unexpected operation, feedback of alarms to the user is provided by LEDs (Green and Red) on the control board.  
N.B.: Do not use the actuator if not coupled with its relating valve.

### OPERATION

The Actuator translates the control signal (modulating or 3 point floating) from the controller into a valve position. A modern brushless DC motor in the actuator drive a gear train and a worm gear – screw jack mechanism convert the motor revolutions into accurate and repeatable linear movements.

### Control Signal

The MVE can be controlled by one of 2 main control types.

- 3 point floating ;
- Modulating (or proportional) signal with filed selectable range (0..10Vdc, 2..10Vdc, 0..5, 2..6Vdc/5..10, 6..10Vdc e 4-20mA.)

### Manual Override

There is a manual operation handle on the Actuator. When it is lowered (manual override ON), the power supply to the motor power stage circuitry is cut and the motor stops. The actuator can be operated manually and the valve positioned accordingly. The manual override lever latches in position until it is raised again, then board and motor will be powered again. At the end of this operation the actuator moves to initial position (on the basis of DIP 1 setting) then it follows the control signal. When the manual override is engaged the green and the red LED are ON.

Manual operation handle can also be used to modify any dip-switch setting or as re-set function after any alarm occurrence. The actuator is supplied with the manual override lowered (ON). It is not necessary to remove power supply to modify dipswitch setting.

### Position Feedback

The MVE utilizes a 2-10V position feedback (refer to DIP 1 setting).

### Calibration

The MVE has both Auto and Manual Stroke Calibration, Sw.7. In factory delivery the auto stroke calibration is enabled – manual calibration is not necessary unless maintenance is required on the valve or certain alarm functions are desired.

### End Point Auxiliary Switches (with accessory DMVE)

End point switches change over when the valve is fully open or closed. End point switches can be utilized to indicate valve stroke end positions and for relay control of additional plant equipment. When the actuators are controlled individually or in sequence, it is possible to use the end switches to toggle when the valve is fully open or fully closed. The auxiliary switch position according to control signal (Y) is shown in the picture below.

Control signal (Y)	Relay KC1	Relay KC2
0 ÷ 0,5V	KC1 to K1	KC2 to K3
0,5 ÷ 9,5V	KC1 to K2	KC2 to K3
9,5 ÷ 10V	KC1 to K2	KC2 to K4

### Diagnostic

The actuator is provided with a self diagnostic algorithm able to detect faulty conditions:

- stroke out of range 5-60 mm;
- unexpected stall condition (e.g. valve stuck);
- missing expected stall condition (e.g. link loose);
- voltage supply out of range.

These faulty conditions are signaled via the Green and Red LED on the PCBA blinking accordingly (see Diagnostic – Alarm Function Table).

## TECHNICAL FEATURES

	MVE506/S	MVE510/S	MVE515/S
Supply voltage L1 Ln	AC: 24 Vac $\pm$ 20% 50-60Hz DC:22-30 Vdc (Reference Ln)		
Power consumption (running)	13 VA / 6 W	18 VA / 8W	21 VA / 11W
Power consumption (Holding)	11 VA / 5 W	11 VA / 5 W	13 VA/7W
Running time			
Modulating 5-15 mm	15 (s)		
Modulating 15-25mm	20 (s)		
Modulating 25-60 mm	30 (s)		
Increase/decrease (s)	60		
Transformer Size (VA)	20	30	50
Stroke (mm)	5-60 mm		
Force (N)	600	1000	1500
Duty cycle	max 50%/60 minutes		
Analog input Y M	Voltage 0-10 V - impedance > 100 K $\Omega$ (range: 0-10/2/10 0-5/2-6 5-10/6-10) 500 $\Omega$ (range 4-20mA)		
Digital inputs Y1-Y2	Connection to L1 or Ln when powered in AC Connection to Ln only when powered in DC		
Output V+	Voltage 16 Vdc $\pm$ 0,5 V Max Load 25 mA,		
Output U	Voltage 2-10 Vdc (0-100%) Max Load 2 mA		
Ambient temperature	Operation and storage -10 / +50 °C		
Ambient Humidity	max 90% RH		
Protection degree	IP54		
Standard	Emission/Immunity EMC 2004/108/CE according to EN 61326-1:2006 standard		
Material	Housing: Aluminum - Cover: ABS plastic		
Color	Aluminum / White		
Weight (Kg)	1.5 kg		
Dimensions (mm)	Refer to the picture on the page 6		

## ASSEMBLING

The actuator can be mounted with any orientation but never up-side down. When the fluid temperature exceed 120°C the actuator shall be mounted leaning 45°.

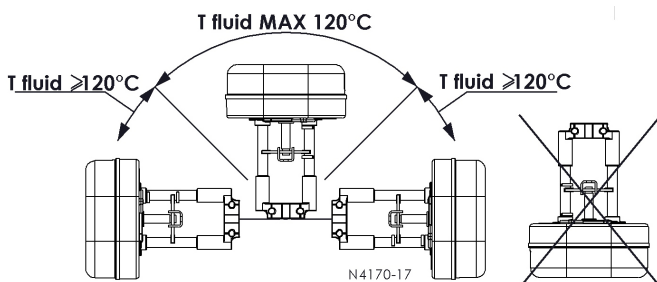

To mount the actuator on to a valve, position the valve stem to the bottom of its travel, slide the actuator onto the valve neck, adjusting with the manual override the screw jack position so the square nut on the valve spindle fits into the groove on the cross bar. Then slide the brace into the groove on the valve neck and secure the nuts.

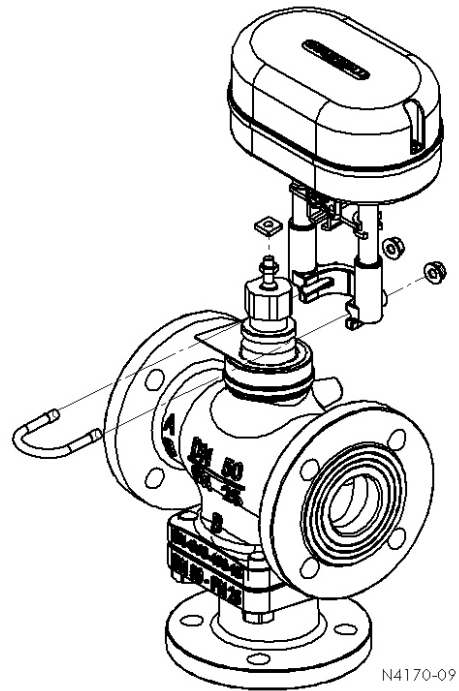

See mounting instructions for full details (MVE\_DIM196).

## MAINTENANCE

The actuator is free of maintenance.

## ACCESSORIES

- DMVE Endpoint Auxiliary Switches
- 248 Yoke Heater (Suggested when the fluid temperature is below 0°C)

Linkage	MVE	MVES
Current Controlli valves (except for 2TGB.F/3TGB.F PN16)	(not required)	/
2TGB.F/3TGB.F PN16	/	(not required)
Controlli valves with threaded M40 connections (except for VMB/VSB/VSBF/VMBF PN16)	AG51	/
VMB/VSB/ VSBF/VMBF PN16	AG52	AG63
<b>Other manufacturers</b>		
Landis *	AG 60-03	/
Danfoss (VR/VF (S) models)	AG60-07	/
TAC DN15-V298	AG 60-08	/
TAC DN15-V2XX/V3XX	AG 60-09	/
Honeywell**	AG 60-10	/
Airtek	AG 60-11/AG60-12	/
Johnson Controls code VB7816-2111	AG 66	/
Johnson Controls code BM-3018-3300	AG 67	/
Tac Venta	(not required)	/

(/) this model can not be assembled

(\*) valid for following models: VVF31... DN 25-80/VVF45... DN 50/VVG41... DN 15-50/VXG41... DN 15-50/VVF51... DN 15-40/VVF52... DN 15-40/VXF31... DN 25-80/VXF61... DN 15-50/VVF61... DN 15-50/VXG11... DN 25-40/VVG11... DN 25-40/VFG34... DN 25-40

(\*\*) valid for the followign models: M6: V176A. B, V538C  
1/4": V5011A

**ELECTRIC CONNECTIONS**

Remove the cover screw with a screwdriver and then remove the cover as shown in the picture beside.

The actuator is equipped with a 8 poles removable terminal block; the each pole of the plug is clearly marked and the same label are reported on the PCB (Printed Circuit Board). Before powering up the actuator make sure the plug is properly connected to the PCB and the label on the plugs and on the PCB match.

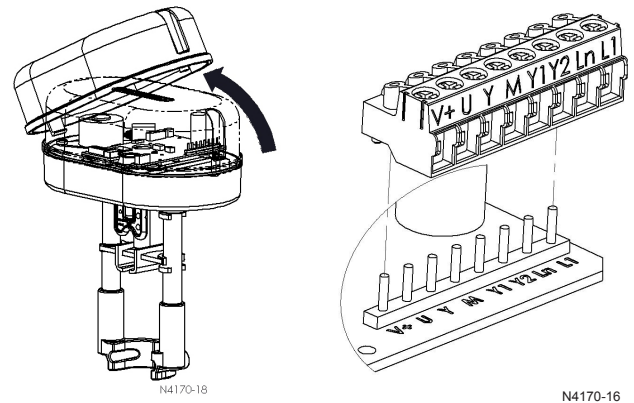

Label	Description	Function	Min Wire Size	Max wire Length
L1	24Vac/Vdc	Power Supply	1.5 mm <sup>2</sup>	75 m
Ln	0V			
Y	0..10Vdc	Modulating Control Input	0.5 mm <sup>2</sup>	200 m
M	0V (Common)			
Y1	Open	Floating Control Input	0.5 mm <sup>2</sup>	200 m
Y2	Close			
V+	16 Vdc	Voltage Output (max 25mA)	0.5 mm <sup>2</sup>	200 m
M	0V (Common)	Feedback Output Signal	0.5 mm <sup>2</sup>	200 m
U	2÷10Vdc			
M	0V (Common)			

**Note:** To avoid damages to electronic components caused by the PCB bending, do not press too much while fixing the terminal block.

**TERMINAL BLOCK**

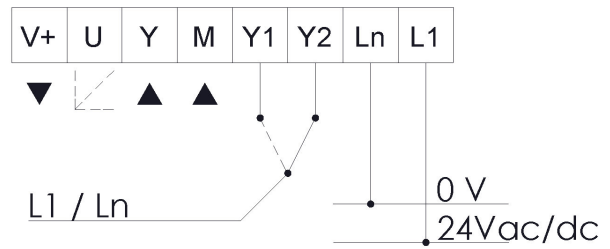

N4170-04

**3p Floating Control (Sink Connection)**

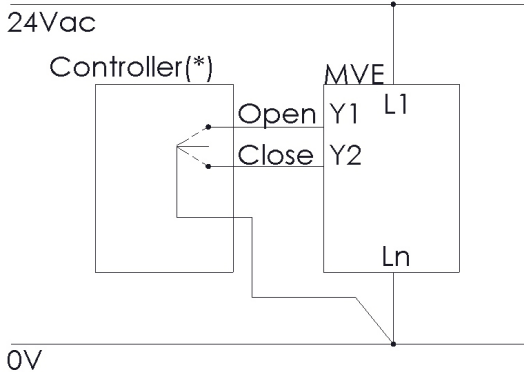

**3p Floating Control (Source connection)**

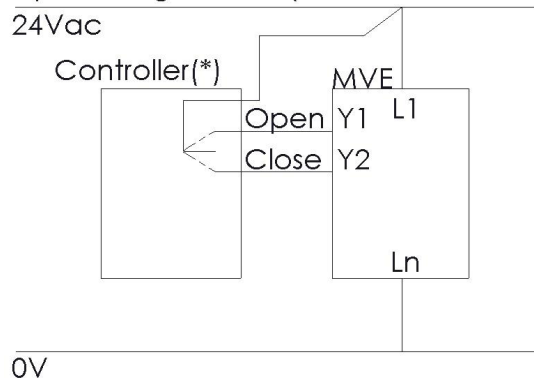

**Modulating Control (0-10 Vcc)**

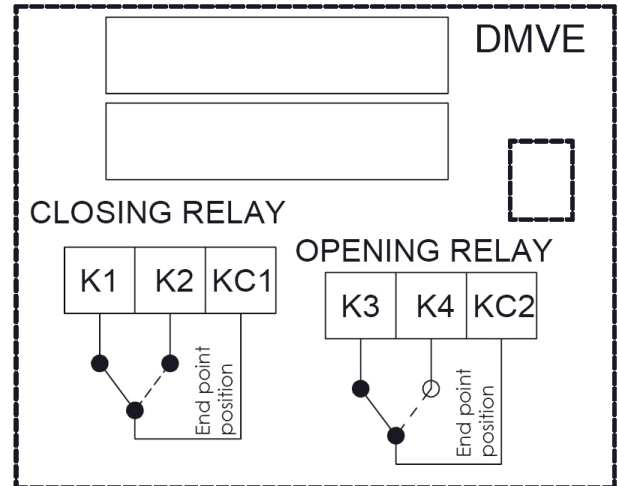
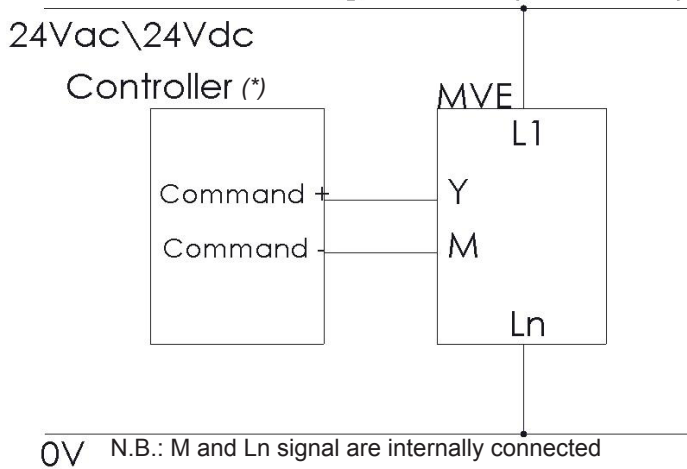

(\*) MVE contain a half-wave rectifier power supply. They must not be powered with transformers that are used to power other devices using not isolated full-wave rectifier power supply.

DIPSWITCHES SETTINGS

Set the dip switches according to the tables here below. Power down and power up again the actuator or act on the manual operation handle to be sure that settings will be recognized.

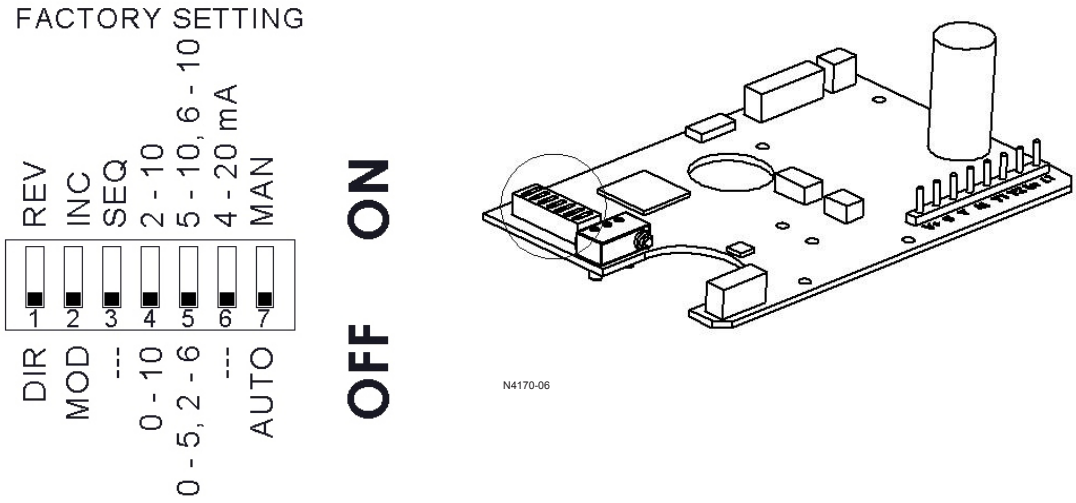

Dip switch	OFF	ON
1	<p>Direct Action</p> <p>U = 2V</p> <p>U = feedback</p> <p>U = 10V</p>	<p>Reverse Action</p> <p>U = 10V</p> <p>U = feedback</p> <p>U = 2V</p>
2	<p>Modulating Control (MOD) (Input between Y [+] and M [-])</p>	<p>3 point floating (INC) ( Y1 open-extend , Y2 close-retract connected L1 or LN)</p>
3	-	Selection of sequence mode, control range defined by SW 5
4	Modulating Control 0-10 Vdc (dip switch 2 OFF only)	Modulating Control 2-10 Vdc (dip switch 2 OFF only)
5	Sequence Control 0-5 Vdc with dip switch 4 OFF only Sequence Control 2-6 Vdc with dip switch 4 ON only (switch 3 ON only)	Sequence Control 5-10 Vdc with dip switch 4 OFF only Sequence Control 6-10 Vdc with dip switch 4 ON only (switch 3 ON only)
6	Voltage Input Signal (input between Y [+] and M [-])	Current Input Signal 4-20mA (input between Y [+] and M [-]). In this case DIP 4 must be ON.
7	Automatic Calibration: the actuator update the stroke range if an unexpected mechanical stop is detected for at least 10 s	Manual Calibration: the actuator calibration is started moving the switch from OFF to ON; if the switch is left in ON the actuator will never update the calibrated stroke value even when an unexpected endpoint is detected

N°	LED	Error	When	Actuator Behaviour		Typical trouble shooting condition	Reset procedure
				Automatic Calibration SW7 OFF	Manual Calibration SW7 ON		
1	<b>RED ON</b>	Calibrated stroke valve less than 5 mm	Calibration / first installation	The actuator pushes/pulls 5 times (unexpected stall) trying to remove the possible obstacle. After 5 tries alarm is signalled (RED Led ON) and the actuator moves to initial position and does not respond to control signal. Stroke value is not updated because out of range	The actuator pushes/pulls 2 times against endpoint during calibration. Alarm is signalled (RED led On) and the actuator moves to the initial position and then it does not repositnd to the control signal.	Valve with a stroke lenght lower than 5 mm	Remove power and power up again
2	<b>RED ON</b>	Stroke longer than 60 mm	Calibration / first installation	The actuator exits the 60 mm stroke range and it moves toward the new stroke limit signalling an anomaly (RED led on). Tha actuator does not calibrate the stroke	The actuator pushes/pulls 2 times against endpoint during calibration. Alarm is signalled (RED led On) and the actuator moves to the initial position and then it does not repositnd to the control signal.	Valve with a stroke lenght longer than 60 mm	Remove power and power up again
3	<b>RED Quick Blinking + GREEN ON</b>	Unexpected stall within the calibrated stroke range	normal operation	The actuator tries 5 times against the new stall condition and then after 10 second the actuator updates the new stroke lenght; During these 10 sec. RED led is ON	The actuator tries 5 times against the new stall condition and then after 10 second the actuator does not update the new stroke lenght	Valve stuck	Inverted control signal
4	<b>RED Quick Blinking + GREEN ON</b>	Stroke longer than expected	normal operation	The actuator moves toward the new stall condition with a lower speed; after 10 second the actuator updates the new stroke value; During these 10 sec. RED led is ON	The actuator moves toward the new stall condition with a lower speed; after 10 second the actuator does not update the new stroke value	stem connection loose or valve damaged	Inverted control signal
5	<b>RED slow Blinking</b>	Low Power Voltage	normal operation	The actuator is still working but performance cannot be guaranteed	The actuator is still working but performance cannot be guaranteed	1. Wrong transformer size 2. unstable power	Correct Voltage Power
6	<b>RED slow Blinking</b>	High Power Voltage	normal operation	The actuator is still working but performance cannot be guaranteed	The actuator is still working but performance cannot be guaranteed	1. Wrong transformer size 2. unstable power	Correct Voltage Power

N°	LED	ACTUATOR STATUS
1	GREEN ON	The actuator arrived at the extreme point of the stroke read
2	GREEN BLINKING	The actuator arrived at the intermediate point of the stroke read
3	RED GREEN BLINKING	The actuator is reading the stroke or it is going to initial position
4	RED GREEN ON	Manual control ON, the actuators ignores the control signal. ATTENTION! The PCB is electrically supplied

DIMENSIONS (mm)

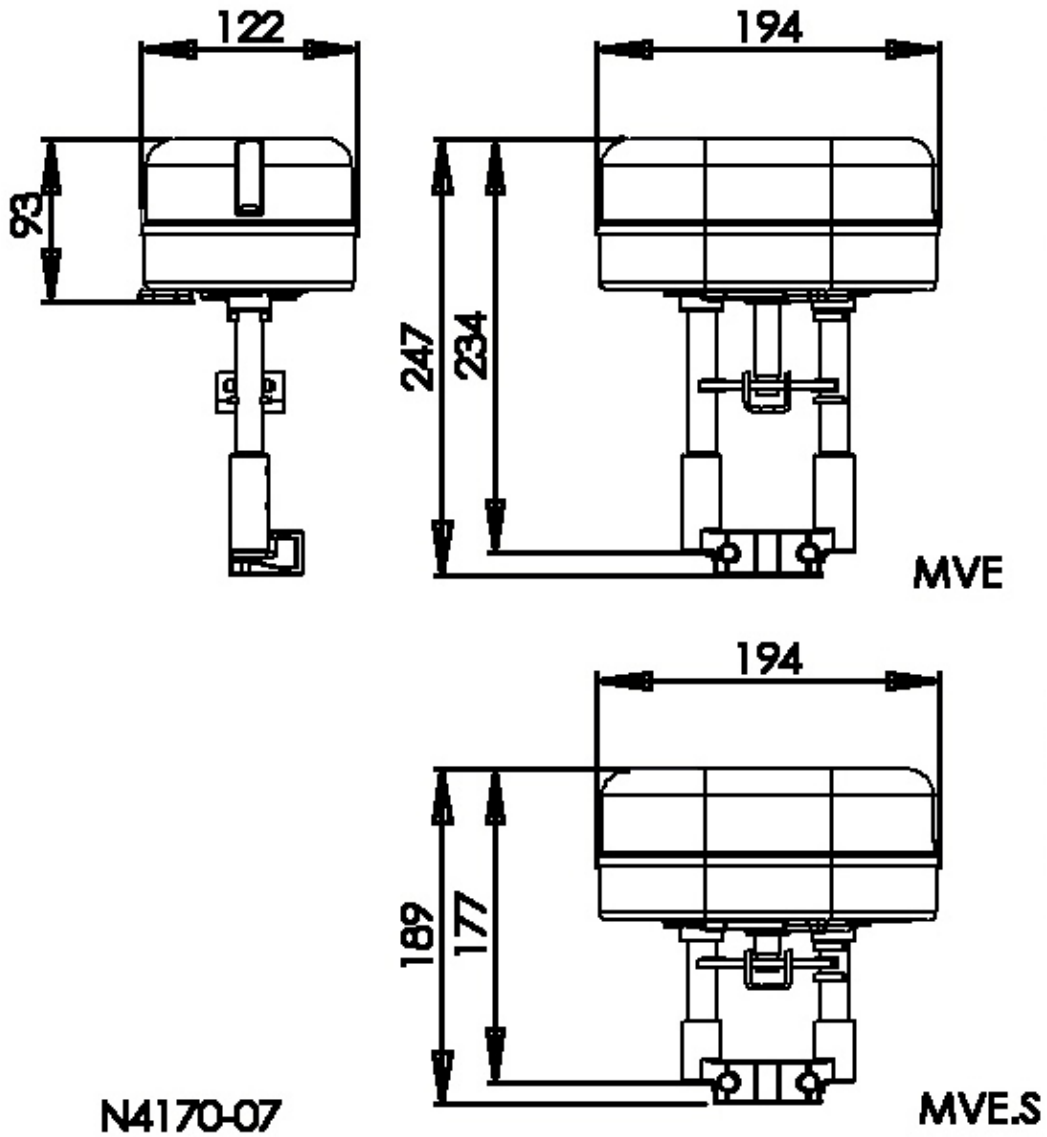

The performances stated in this sheet can be modified without any prior notice due to design improvements