

**N 527/52 Universal dimmer, submodule, islanding  
AC 230 V, 20...1000 VA**

**5WG1 527-1AB52**

## Product and functional description



The universal dimmer submodule N 527/52 is an installation device for DIN-rail mounting, with N-system dimensions. It is designed for lighting control, i.e. for switching and dimming resistive, inductive or capacitive loads from 20 to 1000 VA at 230V AC, 50-60 Hz **especial in electrical system without a synchronous connection to the electrical grid (Islanding)**. It is connected to a universal dimmer main module or to a preceding submodule via a low voltage terminal block. The power supply for the electronics is provided by an integrated 230V AC power supply unit.

### Connecting universal dimmer submodules

You can connect a universal dimmer submodule N 527/52 (see, for example, device E in figure 1) with the 2-pin interface T+, T- (see figure 1, device A) of a universal dimmer main module N 527/32 (dimnable load 20-500 VA) via a twisted pair of wires. Up to 5 universal dimmer submodules can be connected to a universal dimmer main module, in which the twisted pair T+, T- is also to be looped from interface to interface. In this way, a main module can be extended if required from a KNX dimmer with one output to a KNX dimmer with up to 6 outputs.

When connecting a new universal dimmer submodule to a universal dimmer main module, it is essential that you connect their 2-pin interfaces T+/T- first before applying the mains voltage to the submodule(s). This is the only way to guarantee that the communication between main module and submodule(s) takes place correctly.

### DANGER

- The lines T+ and T- are to be installed safely isolated from the 230 V potential. The maximum permitted line length between the main module and the submodule furthest away is 2 m.

## Connection example

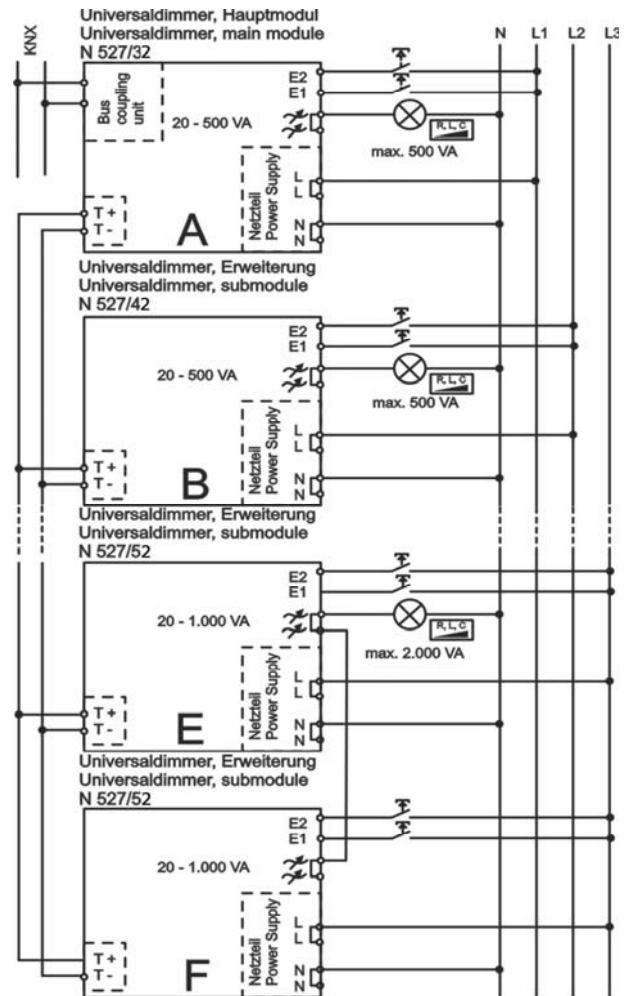

Figure 1. Connection example

### Dimming loads from 40 to 2000 VA

The outputs from two N 527/52 universal dimmer submodules (dimnable load each 20-1000 VA) can be connected in parallel, in order to be able to dim a load in the range from 40-2000 VA (see devices E and F in figure 1).

### DANGER

- You must not connect the outputs from more than two N 527/52 devices in parallel. Parallel operation of the outputs from universal dimmer main modules with each other or with a submodule, as well as of all other universal dimmer submodules, is not permitted!

### Device address

You set to which dimming channel (B...F) of the main module the relevant submodule is to be assigned with a

rotary switch on the underside of the housing (see A1 in figure 2). A universal dimmer main module must always be set on channel A. If two or more devices are set incorrectly to the same address, then the light emitting diodes (LED) for the relevant channels on top of the main module will flash.

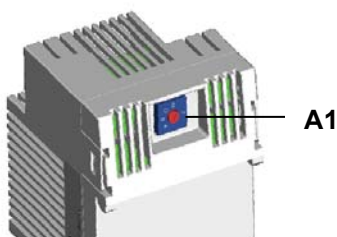

Figure 2. Rotary switch for device address

#### Pushbutton inputs E1, E2

A conventional pushbutton can be connected each to the E1 and E2 inputs of the submodule for direct switching and dimming of the output. Tapping the pushbutton on the E1 input leads to switching on, holding it down to dimming brighter, tapping the pushbutton on the E2 input leads to switching off, holding it down to dimming darker. You use a parameter in the application program of the main module to set whether pressing one of the buttons is also to lead to sending switching and dimming telegrams via the KNX bus to other actuators.



#### DANGER

- On electrical safety reasons, both pushbuttons must be connected to the same phase conductor as the dimmer module in question.

#### Application program

A universal dimmer submodule has its own application program as firmware, supporting the autonomous operation of the submodule even if it is not connected with a main module (or if the communication with the main module fails) by switching and dimming the load via pushbuttons connected to the inputs E1 and E2.

The extensive application program "07B0 A6 Universal dimmer 982101" of a main module controls both the output from the main module and the outputs from all connected submodules. It has to be configured and loaded with the Engineering Tool Software (ETS) from Version ETS 3.0 f upwards. *Inter alia*, it includes monitoring of each channel for short circuit, overload and overheating, switching and dimming status reporting, a warning before switching off, time functions, blocking and releasing a channel, a configurable behaviour at bus voltage failure and recovery, as well as at mains voltage recovery, and an integrated 8-bit scene control in which each channel can be integrated in up to 8 scenes.

#### Behaviour at voltage failure / recovery

Because the power for the submodule's electronics is generated via an integrated 230 V AC power supply unit, a mains voltage failure means that the affected output is switched off and that this module fails completely. The submodule will remain switched off after mains voltage recovery if the main module didn't receive any switching or dimming commands for this module during mains voltage failure at it. Otherwise the main module will transmit the last meanwhile received switching / dimming command to the submodule after mains voltage recovery at this module.

In the event of a mains voltage failure at the main module, night mode is ended if it is active and the current switching states and dimming values of all modules (channels) are stored permanently, in order that they can be regenerated automatically after mains voltage recovery. You use a parameter to configure the behaviour after mains voltage recovery: switching on all channels, switching off all channels, restoring the switching / dimming states of all channels at mains voltage failure. However, if night mode was active before mains voltage failure, this will not be re-enabled.

In contrast, a bus voltage failure results only in a communication failure via the KNX bus. But communication between the main module and all connected submodules via the interface T+ / T- is unaffected by this. Each module retains its current status. If pushbuttons for direct switching and dimming are connected to a module's pushbutton inputs E1, E2, you can use these connected buttons to switch and dim this module. You can also select each module (i.e. each channel) with the pushbuttons on the top of the universal dimmer main module and switch and dim in direct mode. Parameters are used to set the behaviour in each case on bus voltage failure and on bus voltage recovery.

**N 527/52 Universal dimmer, submodule, islanding  
AC 230 V, 20...1000 VA**

**5WG1 527-1AB52**

## Technical specifications

### Mains supply

- Rated voltage: 230 V AC, +10% / -15%, 50-60 Hz
- Rated current: 4.4 A
- Power loss if output A = OFF: 0.4 W,  
maximum power loss at trailing edge dimming: 5.8 W,  
maximum power loss at leading edge dimming: 6.0 W.

### Pushbutton inputs

- 2 inputs
- Rated voltage: 230 V AC, 50-60 Hz
- Maximum length of the connecting cable: 100 m

### Load output

- Rated voltage: 230 V AC, 50-60 Hz
- Rated current: 4.4A
- Connection output at 45 °C ambient temperature:
  - Incandescent lamps: 20...1000 W
  - High voltage halogen lamps: 20...1000 W
  - Low voltage halogen lamps with electronic transformers: 40...1000 VA
  - Low voltage halogen lamps with magnetic transformers: 20...800 VA
  - Osram dimmable energy-saving lamps: 1...20 units 15 VA resp. 20 VA

### Short circuit / overload protection

Electronic protection, i.e. the universal dimmer cuts off if there is a short circuit or overload. After resolving the short circuit / overload, the universal dimmer can be reconnected by switching off and on again or by interrupting the mains voltage until a period of at least 2 minutes has elapsed.

### Temperature rise protection

Electronic protection, i.e. the universal dimmer dims to the minimum dimming value if the maximum permitted temperature is exceeded. When the excess temperature has fallen to below the maximum permitted value, the universal dimmer reverts to the previous dimming value after 2 minutes.



## DANGER

- If the device is mounted in a cavity floor or is used for overhead or horizontal installation the reduction of the maximum connected power as shown in figure 3 applies.
- Connecting mixed loads to the same output is allowed in the following cases:
  - Low voltage halogen lamps with an electronic transformer together with incandescent lamps and high voltage halogen lamps.
  - Low voltage halogen lamps with a magnetic transformer together with incandescent lamps and dim-

mable energy-saving lamps from Osram, if the parameter "Load adaptation" has been set from "Automatic load adaptation" to "Leading edge control".

- Magnetic transformers may only be used if they comply with the relevant standards and contain a thermal fuse.
- With Osram's dimmable energy-saving lamps, the parameter "Load adaptation" must be set from "Automatic load adaptation" to "Leading edge control" and the parameter "Minimum dimming value" to a value  $\geq 20\%$ .

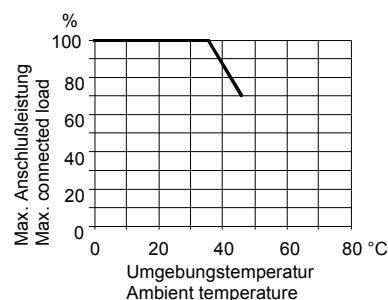

Figure 3. Max. connected load, depending on the ambient temperature

### Operating elements

- none

### Display elements

- none

### Connections

- Mains, load and pushbuttons connections:
  - Screw-type terminals, insulation strip length 7... 9 mm. The following conductor cross-sections are permitted:
    - 0,5... 4.0 mm<sup>2</sup> single core,
    - 0,5... 2.5 mm<sup>2</sup> finely stranded, without / with connector sleeve
- Submodule: Low voltage terminal block, screwless, conductor cross-section 0.6 ... 0.8 mm Ø single core, insulation strip length 5 mm, maximum length of cable between modules A and F: 2 m

**Mechanical data**

- Housing: plastic
- Dimensions: device for DIN-rail mounting with N-system dimensions, width 3 MU (1 Module Unit = 18 mm)
- Weight: approx. 125 g
- Fire load: approx. 2140 kJ
- Installation: Snap-on mounting on DIN rail EN 60715-TH35-7.50

**Electrical safety**

- Degree of pollution (according to IEC 60664-1): 2
- Protection type (according to EN 60529): IP 20
- Overvoltage category (according to IEC 60664-1): III
- Device complies with: EN 50428

**EMC requirements**

- complies with EN 50428

**Environmental conditions**

- Climatic withstand capability: EN 50090-2-2
- Ambient operating temperature: - 5 ... + 45 °C
- Storage temperature: - 25 ... + 70 °C
- Relative humidity (not condensing): 5 % to 93 %

**Reliability**

- Failure rate: 547 fit at 40°C

**CE mark**

- In accordance with the EMC guideline (residential and functional buildings), low voltage guideline

**Position and function of the display and operating elements**

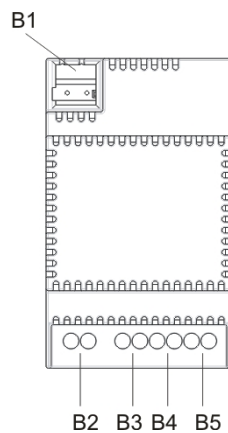

Figure 4. Display / operating elements

- B1 Plug for low voltage terminal block for connecting universal dimmer submodules
- B2 Screw terminals for connecting / looping the N-conductor
- B3 Screw terminals for connecting / looping the L-conductor
- B4 Screw terminals for connecting the load
- B5 Screw terminals for connecting in each case a pushbutton for direct switching and dimming of the load connected to the output

**Mounting and wiring**

**Installation notes**

The device can be used for permanent installation in dry interior rooms and for insertion in control cabinets or small distribution boards.

Mounting and dismounting the device:  
see figure 5 and figure 6

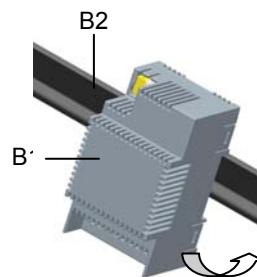

Figure 5. Mounting on a DIN-rail

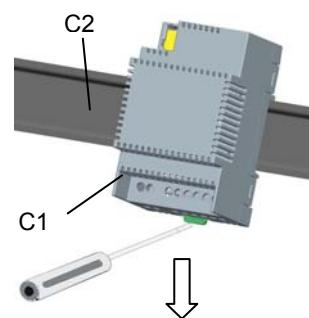

Figure 6. Dismounting from a DIN-rail

Connecting a universal dimmer submodule:  
see figure 7

Snap the universal dimmer submodule on to the DIN-rail and interconnect the T+ and T- connections from the universal dimmer main module and the universal dimmer submodule via a twisted pair of wires. After this connect the AC power line and switch the mains voltage on.

**N 527/52 Universal dimmer, submodule, islanding  
AC 230 V, 20...1000 VA**

**5WG1 527-1AB52**

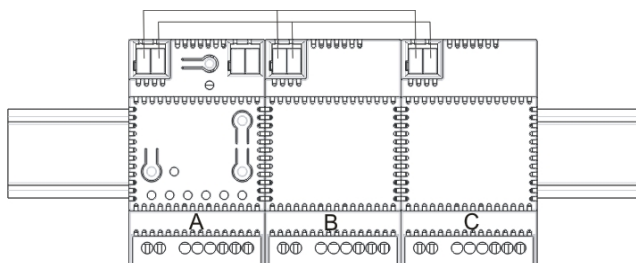

Figure 7. Connecting universal dimmer submodules

Connecting the twisted pair T+ / T-:  
see figure 8

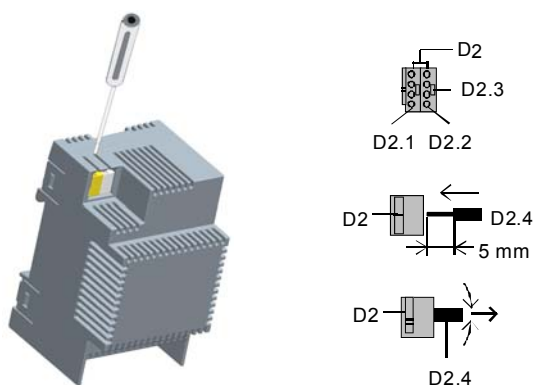

Figure 8. Connecting the twisted pair T+ / T-

### DANGER

- The system may only be installed and commissioned by an authorized electrician.
- If the phase conductor connected to the device is to be looped to one or more submodules, then the phase conductor is to be fused with a miniature circuit breaker with B or C characteristic for a rated current of 16A, in order that the maximum permissible terminal current is not exceeded.
- If the main module and the submodules connected to it are to be used on more than one phase, then the third harmonics of the load currents are summed in the jointly fed neutral conductor. In this way, the neutral conductor can be loaded more heavily than the phase conductors. The neutral conductor in this case is to be rated adequately or protected against excessive current, as there may otherwise be a fire risk.
- Running magnetic transformers at no load is prohibited both on start-up and in operation, because this may lead to damage to the device (even when the dimmer has cut off). This is to be ensured by connect-

ing at least two lamps or transformers in parallel to an output. Failed lamps are to be replaced immediately.

- The device may only be operated vertically with the ventilation slots at the top and at the bottom. The device must be well ventilated. Heat dissipation must be ensured.
- This device contains a varistor. Due to a disruption of the neutral conductor, overvoltage or conventional transformers running at no load, damage may arise which can lead to the failure of the device at a later date. The conductors (outer and neutral conductor) are to be connected with each other for dielectric tests.
- For dielectric tests of cables, which measure core against core contrary to the current valid norm DIN VDE 0100 T. 610, the device must be disconnected, because otherwise it may be damaged.
- When connecting the device, it should be ensured that the device can be isolated.
- The device must not be opened.
- For planning and construction of electrical installations, the relevant guidelines, regulations and standards of the respective country are to be considered.

### Dimension drawing

Dimensions in mm

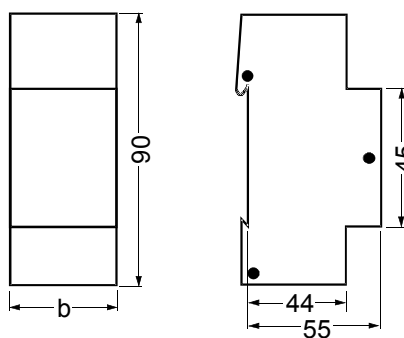

$b = 3 \text{ MU}$

1 Module Unit (MU) = 18 mm



**N 527/52 Universal dimmer, submodule, islanding  
AC 230 V, 20...1000 VA**

**5WG1 527-1AB52**

**General notes**

- The operating instructions must be handed over to the client.
- Any faulty device is to be sent together with a return delivery note of the local Siemens office.
- If you have further questions concerning the product please contact our technical support.

**Technical Support**

 +49 (911) 895-7222  
 +49 (911) 895-7223  
 support.automation@siemens.com  
[www.siemens.de/automation/support-request](http://www.siemens.de/automation/support-request)

**Space for notes**