



Synco™ living

Room Temperature Sensor

QAA910

-
- **Wireless room temperature sensor for acquiring the room temperature**
 - **RF communication based on KNX standard (868 MHz, unidirectional)**
 - **Battery-powered by commercially available 1.5 V batteries**

Use

- For integration into the Siemens Synco living system
- For acquiring the room temperature in HVAC plant
- Especially suited for:
 - Renovation projects (old buildings, museums, churches, historical buildings, etc.)
 - Difficult wall-mounting situations (sandstone, glass, etc.)
 - Variable floor plans (different décors, other furniture)
 - New construction projects

Equipment combinations

The QAA910 room temperature sensor is designed for use with the Siemens Synco living system. For more detailed information about equipment combinations, refer to the Data Sheet of the central apartment unit (CE1N2707en).

Ordering

When ordering, please give quantity, product name and type reference.

Scope of delivery

Each QAA910 is supplied complete with a set of alkaline batteries, fixing material and Mounting Instructions.

Product documentation

The Operating and Commissioning Instructions for the QAA910 are contained in the product documentation of the central apartment unit.

Functions

Main function

During operation, the QAA910 forwards the acquired room temperature to the central apartment unit, either periodically or in the case of changes.

Binding

The binding is used by the QAA910 to sign on at the central apartment unit, thus integrating it into the RF system. The binding process is triggered via the multifunction button. It is indicated by the multifunction LED.

Status query

The multifunction button can be used to query the batteries' capacity. It is indicated by the multifunction LED.

RF binding test

The multifunction button can be used to trigger a binding test. This test is made to check the radio link to the central apartment unit. The RF binding test is indicated by the multifunction LED.

Error and maintenance messages

All error and maintenance messages are forwarded to the central apartment unit where they appear on the display.

The following messages are delivered by the QAA910:

Error messages	Maintenance message
Sensor error (failure of the room temperature sensor)	Batteries discharged (battery life \leq 3 months)

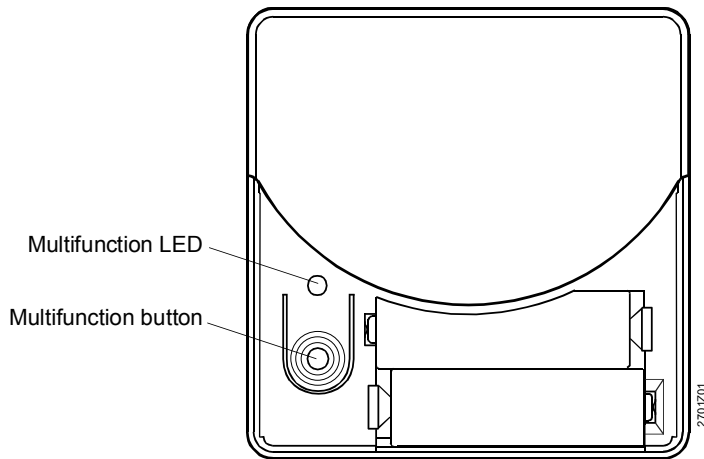

Overview of functions of the indicating and operating elements of the QAA910:

Multifunction LED	Multifunction button
<ul style="list-style-type: none"> • Battery state • Binding process 	<ul style="list-style-type: none"> • Battery state query • Binding • RF binding test

For more detailed information about the functions and operation of the QAA910, refer to the product documentation covering the central apartment unit.

Notes on engineering and operation

Mounting location

The QAA910 must be mounted inside the house or building, on an inner wall about 1.5 m above the floor.

To ensure that the QAA910 will acquire the room temperature as accurately as possible, the following conditions must be observed:

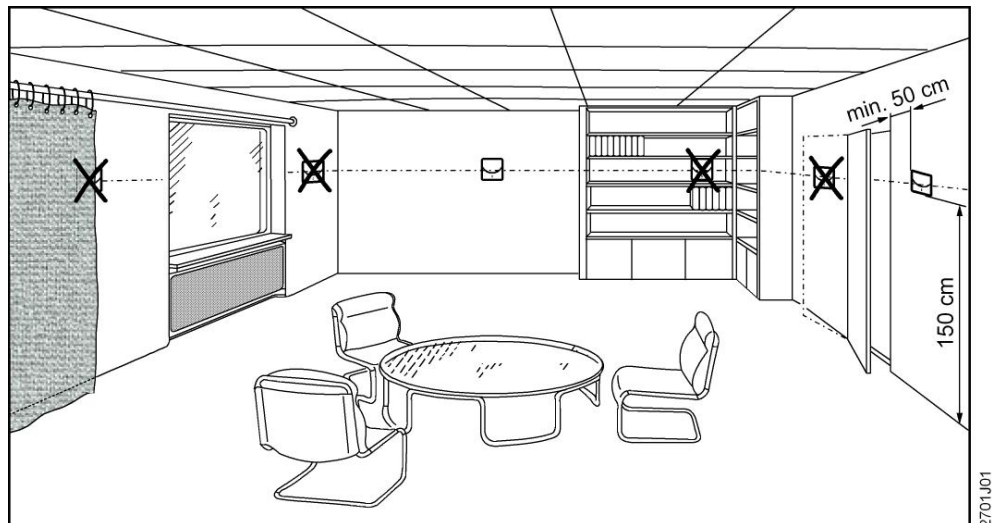

- The QAA910 must not be mounted on an outer wall, not in niches, bookshelves, and not behind doors or curtains
- Temperature acquisition must not be adversely affected by direct solar radiation, air drafts, or other heat or refrigeration sources
- The permissible environmental conditions must be observed
- The QAA910 must not be exposed to dripping water

- For notes relating to engineering and mounting RF devices of the Siemens Synco living system, refer to Data Sheet CE1N2708en.
- The base of the QAA910 must be fitted on a flat wall
- Minimum clearance at the bottom should be 60 mm to ensure that the battery compartment can be easily opened

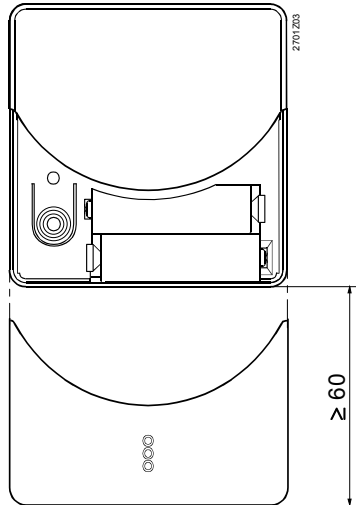

Mounting

Mounting with the base.

The QAA910 can be fitted to most commercially available recessed conduit boxes or directly on the wall.

Note

Mount the QAA910 first and then insert the batteries.

Commissioning

Prior to commissioning, check to ensure that the QAA910 is correctly fitted to the wall and that the batteries are correctly inserted.

Maintenance / battery change

The QAA910 is maintenance-free.

The system indicates when batteries must be replaced. The batteries are located in the battery compartment. Batteries can be changed without removing the sensor from the wall and there is no need to use tools (reversed polarity protection).

Disposal



The device is considered an electronics device for disposal in terms of European Directive 2012/19/EU and may not be disposed of as domestic garbage.

- Dispose of the device through channels provided for this purpose.
- Comply with all local and currently applicable laws and regulations.
- Dispose of empty batteries in designated collection points.

Warranty

Application-related technical data are only warranted in connection with the Siemens Synco living system. For equipment combinations, refer to the Data Sheet of the central apartment unit.

When using the QAA910 together with third-party devices, correct functioning must be ensured by the user. In that case, Siemens will assume no responsibility for service and warranty.

Technical data

Power supply	Type of battery	2 x alkaline batteries LR6 (AA) 1.5 V		
	Battery life (capacity ≥ 2.5 Ah)	3 years		
RF	Frequency	868 MHz (unidirectional)		
	Range	typically 30 m inside buildings		
	Protocol	KNX RF compatible 		
Temperature sensor	Sensing element	NTC 10 kOhm resistor		
	Measuring range	0...50 °C		
	Time constant	20 minutes		
Standards, directives, and approvals	Product standard	EN 60730-1. Automatic electronic controls for household and similar use.		
	Product family standard	EN 50491-x General requirements for Home and Building Electronic Systems (HBES) and Building Automation and Control Systems (BACS).		
	Electromagnetic compatibility (application)	For residential, commercial, and industrial environments.		
	EAC conformity	Eurasia Conformity		
	EU conformity (CE)	CE1T2701xx*		
	Environmental compatibility	The product environmental declaration (CE1E2701en*) contains data on environmentally compatible product design and assessments (RoHS compliance, materials composition, packaging, environmental benefit, disposal).		
	*) These documents can be downloaded at http://siemens.com/bt/download refer to "Dimensions"			
Dimensions				
Weight	Unit complete with accessories	0.214 kg		
Housing material	plastic ASA+PC			
Housing color	white NCS S 0502-G			
Environmental conditions		operation	transport	storage
		IEC 60721-3-3	EN 60721-3-2	EN 60721-3-1
	Climatic conditions	class 3K5	class 2K3	class 1K3
	Temperature	0...+50 °C	-25...+70 °C	-20...+65 °C
	Humidity	5...95 % r.h. (noncondensing)	<95 % r.h.	5...95 % r.h.
	Mechanical conditions	class 3M2	class 2M2	class 1M2
	Elevation above sea level	min. 700 hPa, corresponding to max. 3000 m above sea level		

¹⁾ Completely mounted

Dimensions

Dimensions in mm

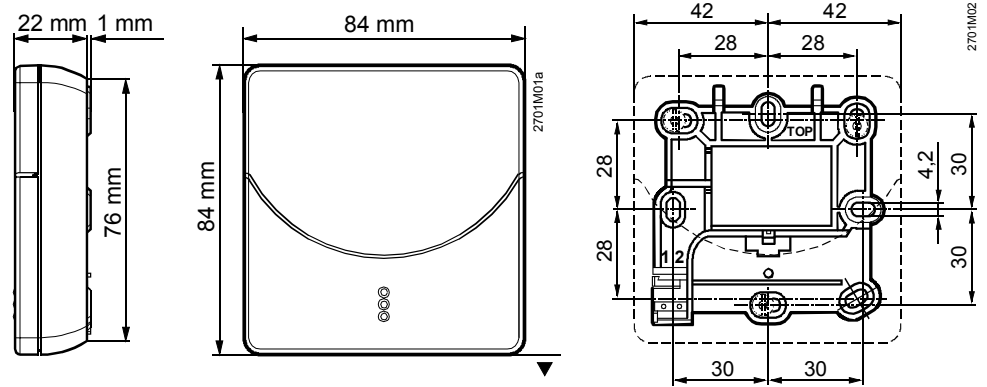

Issued by
Siemens Switzerland Ltd
Building Technologies Division
International Headquarters
Gubelstrasse 22
6301 Zug
Switzerland
Tel. +41 41-724 24 24
www.siemens.com/buildingtechnologies

© Siemens Switzerland Ltd, 2006
Technical specifications and availability subject to change
without notice.