



## Room thermostat with large display

# RDH10M

Boiler control with OpenTherm Plus interface

- Large display
- Powered by OpenTherm bus
- Permanent self-learning, adaptive PID control

### Use

In combination with Boiler Management Units (BMU) or heating controllers equipped with OpenTherm Plus interface. For control of the room temperature in:

- Homes
- Residential buildings
- Schools
- Offices

For use in all types of standard heating systems, such as radiator or convector heating systems. Especially suited for heating plants with pump heating circuits. If the boiler control system features integrated mixing valve control, it is also possible to control mixing heating circuits.

## Functions

---

- Pure room temperature control
- Permanent self-learning PID control for normal and fast controlled systems
- 2-position control for difficult controlled systems
- Reset function
- Display of error code in case of faults

### Temperature sensor

The RDH10M provides control of the room temperature only. The unit acquires the room temperature with its integrated sensor.

### Display

The large digital display shows the actual room temperature and the temperature setpoint for Comfort mode. When the heating output is active, or the BMU reports that the burner is on, the triangle symbol appears.

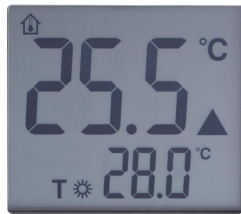

### Backup

Optional batteries are used for continuous operation of the thermostat in case the BMU is switched off or OpenTherm bus power is lost. If the batteries are removed, the information required and operation are maintained for maximum 2 minutes.

## Ordering

---

When ordering, please give description and product no.:  
**Room thermostat RDH10M or S55770-T173.**

### Note !

**The batteries are not included in delivery**

## Fault reporting

---

### Communication

The OpenTherm bus is used for communication between room thermostat and boiler control. The RDH10M must therefore be used in connection with a boiler operating with OpenTherm Plus.

OpenTherm Plus affords reading and writing of several compatible standard objects between room thermostat and boiler control via the bus.

Immediately after installation, the thermostat examines if the connected BMU supports the OpenTherm Plus protocol. If not supported, or in the event of a BMU power failure, the following fault status message is displayed:

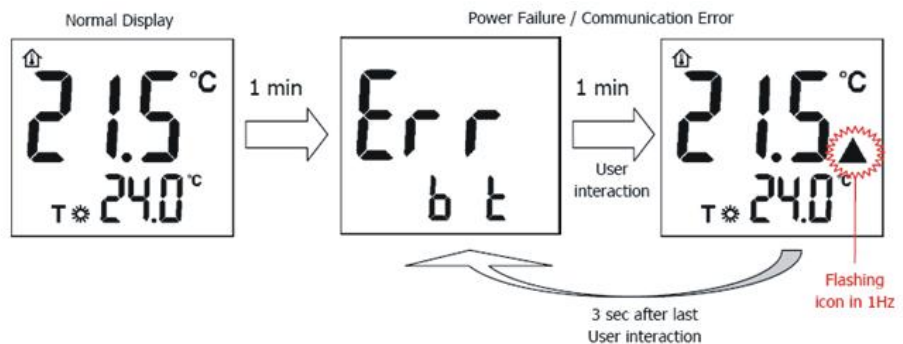

**Err b t** is the abbreviation used for the communication between “b” (boiler) and “t” (thermostat). Once the fault is corrected, **Err b t** disappears and the LCD returns to normal operation.

### BMU fault

In the event the BMU malfunctions, the following information appears on the display:

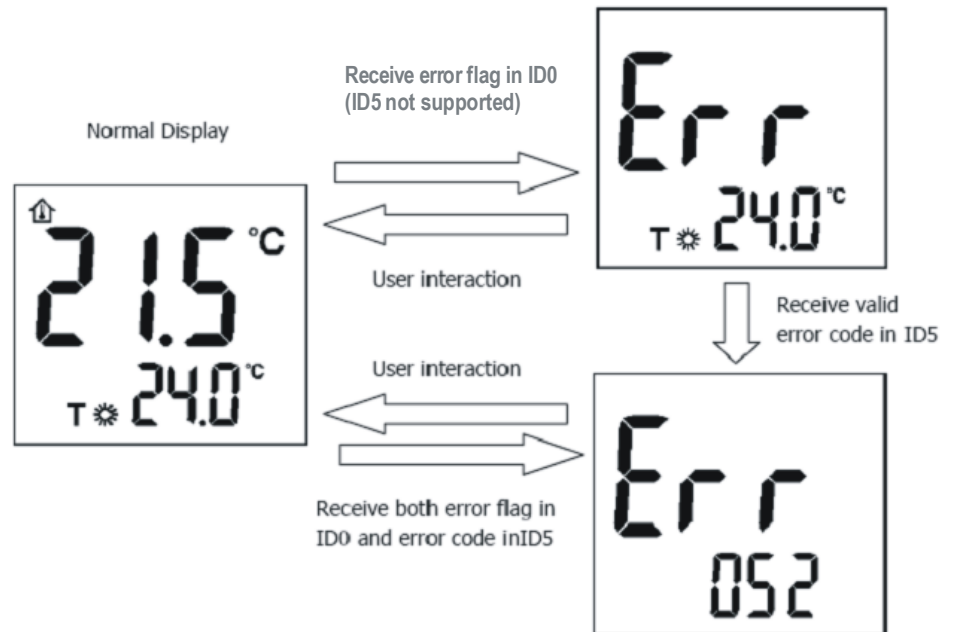

For a BMU that supports only ID0 flag, the LCD displays only **Err**.

For a BMU that supports both ID0 and ID5 flag, the LCD displays the **Err** code and the number. Please refer to the Manual of the BMU to identify the error associated with the 3-digit number displayed.

Once the fault is corrected, **Err** disappears and the LCD returns to normal operation.

## Control

### Access

To enable the control algorithm, press the PID/2-PT pin at the rear of the thermostat. Then use the rotary knob on the front to select the control mode.

The RDH10M is a communicating thermostat capable of providing PID mode. The control (boiler and RDH10M together) ensures room temperature control depending on the deviation of the actual value acquired by the integrated temperature sensor from the setpoint.

The rate of response to the deviation depends on the selected control algorithm:

### Permanent self-learning operating mode PSL

The thermostat operates in self-learning mode, whereby it automatically adapts to the controlled system (type of building construction, heating capacity, type of heating, room size). After a learning period, the thermostat optimizes the parameters and then operates in accordance with the newly learned parameters.

### Exceptions

In exceptional cases, in which the permanent self-learning mode may not be ideal, PID12, PID 6 or 2-Pt mode can be selected:

### PID12

PID12 mode: For normal or slow controlled systems (massive building structures, large spaces, cast iron radiators, oil burners).

### PID 6

PID 6 mode: For fast controlled systems (light building structures, small spaces, plate radiators or convectors, gas burners) (factory setting).

## 2-PT

2-PT mode: Simple 2-position control with a switching differential of 0.5 °C (±0.25 °C) for very difficult controlled systems with considerable outside temperature variations.

### Reset functions

#### User-defined data

Press the pin behind the small opening at the rear for at least 1 second: This resets the user-specific settings and all BMU readings.

After the reset, the factory settings are reloaded and OpenTherm communication is restarted.

### Caution

Without having the batteries inserted, reset functions correctly for a maximum of 2 minutes only after removing the thermostat from its baseplate.

### Mechanical design

The room thermostat consists of 3 parts:

- Plastic housing with digital display, accommodating the electronics, the operating elements and the built-in room temperature sensor
- Baseplate (mounting base)
- Removable battery compartment

The housing engages in the baseplate and snaps on. The baseplate carries the screw terminals. There is a reset pin and a PID/2-PT pin at the rear of the unit.

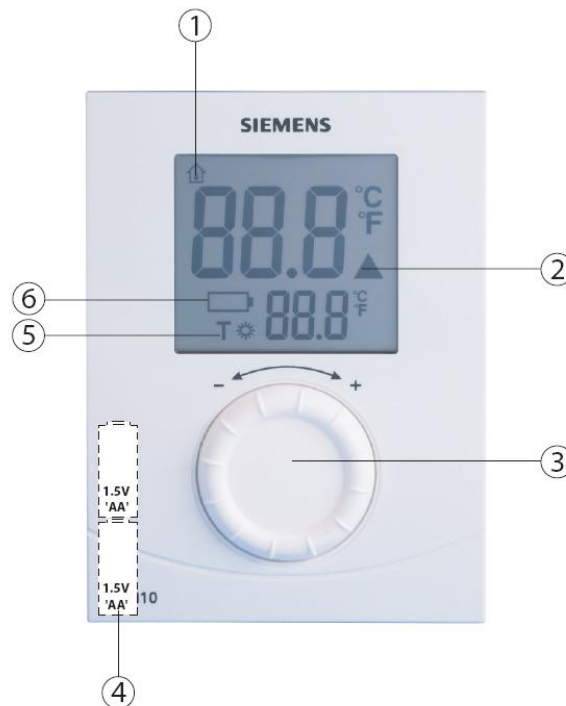

### Key

- 1 Display of the room temperature in °C
- 2 Indicates a request for heat, or when the BMU reports "Burner on"
- 3 Rotary knob for setting the room temperature
- 4 Battery compartment
- 5 Temperature setpoint for Comfort mode
- 6 Indicates low battery power – replace batteries

## Notes

---

Mount the room thermostat in a location where the air temperature can be acquired as accurately as possible without getting adversely affected by direct solar radiation or other heat or refrigeration sources.

Mounting height is about 1.5 m above the floor.

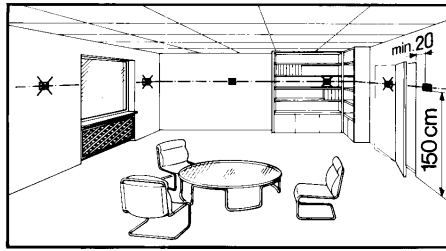

The thermostat can be fitted to a recessed conduit box.

### Mounting, installation and commissioning

When mounting the thermostat, fix the baseplate first. Then, make the electrical connections and fit and secure the thermostat (also refer to separate Mounting Instructions).

Mount the thermostat on a flat wall and in compliance with local regulations.

If there are thermostatic radiator valves in the reference room, set them to their fully open position.

### Maintenance

The thermostat is maintenance-free.

### Change of batteries

If the battery symbol  appears, the batteries are almost exhausted and must be replaced.

### Disposal

---



The devices are considered electronics devices for disposal in term of European Directive 2012/19/EU and may not be disposed of as domestic waste.

- Dispose of the device via the channels provided for this purpose
- Comply with all local and currently applicable laws and regulations.
- Dispose of empty batteries at designated collection points.

## Technical data

Power supply	OpenTherm bus	
	Connection	2 wires (interchangeable)
	Length of cable	Max. 50 m
	Resistance of cable	Max. 2 x 5 $\Omega$
	Power consumption	35 mW (typical)
Battery data	Batteries (Alkaline AA) (optional)	2 x 1.5 V
	Battery life	Approx. 2 years
Sensing element	Sensing element	NTC 10 k $\Omega$ $\pm$ 1% at 25 °C
Operational data	Switching differential SD	1 K
	Setpoint setting range	5...30 °C
	Factory-set Comfort setpoint	20 °C
	Resolution of settings and displays	
	Temperature setpoint	0.5 °C
	Display of actual temperature value	0.5 °C
Electrical connections	Connection terminals (via baseplate)	Screw terminals
	For solid wires	2 x 1.5 mm <sup>2</sup>
	For stranded wires	1 x 2.5 mm <sup>2</sup> (min. 0.5 mm <sup>2</sup> )
Environmental conditions	Operation	IEC 60721-3-3
	Climatic conditions	Class 3K5
	Temperature	0...40 °C
	Humidity	<90% r.h.
	Transport	IEC 60721-3-2
	Climatic conditions	Class 2K3
	Temperature	-25...60 °C
	Humidity	<95% r.h.
	Mechanical conditions	Class 2M2
	Storage	IEC 60721-3-1
	Climatic conditions	Class 1K3
	Temperature	-10...60 °C
Humidity	<90% r.h.	
Standards	EU Conformity (CE)	CE1T3073xx *)
	 OpenTherm Plus (OT/+)	OpenTherm protocol specification 3.0
		OpenTherm test specification 2.0
	Safety class	III as per EN 60730-1
	Pollution degree	2
	Degree of protection of housing	IP20
General	Weight (incl. packaging)	
	RDH10M	340 g
	Color of housing front	Signal-white RAL 9003
	Housing material	ABS
	LCD - transparent cover	PC

\*) The documents can be downloaded from <http://siemens.com/bt/download>.

## Connection diagram

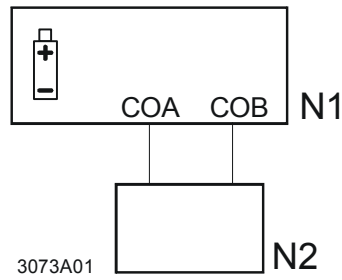

- N1 Room thermostat RDH10M  
 COA OpenTherm contact A (interchangeable)  
 COB OpenTherm contact B (interchangeable)  
 N2 BMU OpenTherm Plus

## Application examples

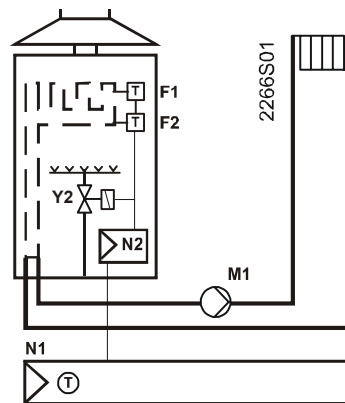

Instantaneous water heater

- F1 Thermal reset limit thermostat  
 F2 Safety limit thermostat  
 M1 Circulating pump  
 N1 Room thermostat RDH10M  
 N2 BMU  
 Y2 Motorized 2-port valve

## Dimensions

### Room thermostat

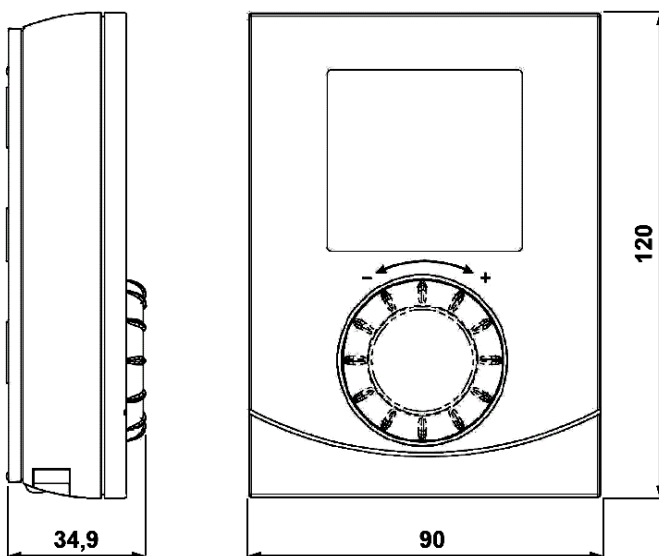

### Baseplate

