

RT226-MB24-S.W Series WiFi Thermostat User Guide



WiFi+Modbus

For Fan Coil Unit

Welcome

Thank you for your purchase. Your new thermostat will provide uniform and comfortable temperature control throughout every room in your property. We bring together technology, craftsmanship and the highest quality materials to provide you with a safe, reliable product combined with sleek, contemporary design.

Please read this installation/programming manual for comprehensive instructions on installing and operating your thermostat. Please also ensure a suitably qualified person installs your thermostat and complies with all local regulations.

In the box you will find

Thermostat	1pc	Screws	2pc
User Guide	1pc	Wall plate	1pc
QC Passed	1pc		

ABOUT YOUR THERMOSTATS

BAC-1000 series Modern Round Touch Screen Room Thermostats are designed to on/off control the fans and valves in air conditioner applications via comparison of the room temperature and setting temp. as reaching the aim of comfort and saving energy.

MODEL DEFINITION

- A : Two pipe; Control Fan Coil Unit and Two Wired Motorized Valve
- M : Two pipe; Control Fan Coil Unit and 0-10V Motorized Valve
- E : Four pipe; Control Fan Coil Unit and Two Wired Heat Valve and Two Wired Cool Valve.
- N : Modbus RTU communication B: BACnet communication
- W : Wifi connection
- K : Keycard T : Clock
- W2 : Window P : Programmable
- E : External Sensor

For example: BAC-1000ALW

FEATURES

On Appearance

- 86mm hidden box and european 60mm round box is suitable.
- White, black or gold housing creates your colorful life.
- White backlight protect your eyes
- Touch buttons to make simple operation.
- Amazing Silver Frame opens your modern life.

On Functionality

- Powerful functions are available such as Modbus/WIFI etc.,
- 0.5°C Accuracy keeps temperature within the level you set.
- Data memory when power is off.
- 5+2 six periods programmable maximize comfort and economy.
- Create thermostat group to centrally control.
- Integrated with **Amazon Echo, Google Home, Tmall Genie, IFTTT.**
- Support Device Sharing.
- All setting languages synchronize your time zone, address and language
- No limit to add room.
- Support Smart Scene.

DIMENSION

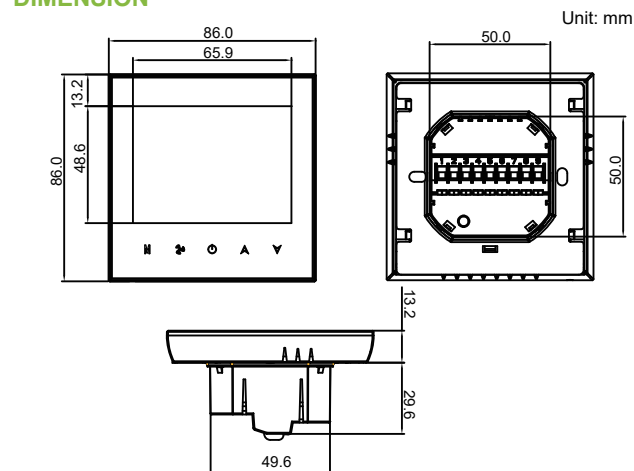

TECHNICAL DATA

- Power Supply: 95 ~ 240 VAC, 50 ~ 60HZ
- Fan Relay Amps Resistance: 5A; Inductive: 3A
- Valve Relay Amps Resistance: 3A; Inductive: 1A
- Sensor: NTC3950, 10K
- Accuracy: ±0.5 C
- Set Temp. Range: 5 -35 C
- Dispaly Temp. Range: 5 ~ 99 C
- Ambient Temp.: 0 ~ 45 C
- Ambient Humidity: 5 ~ 95 % RH (Non Condensing)
- Storage Temp.: -5 ~ 45 C
- Power Consumption: <1.5W
- Timing Error: < 1%
- Shell Material: PC +ABS (Fireproof)
- Installation Box: 86 * 86mm Square or European 60mm Round Box
- Wire Terminals: Wire 2 x 1.5 mm2 or 1 x 2.5 mm2
- Protection Class: IP20
- Buttons: Capacitive Touch Buttons

BEFORE WIRING AND INSTALLING...

- Read these instructions carefully. Failure to follow them could damage the product or cause a hazardous condition.
- Check the ratings given in the instructions and on the product to make sure the product is suitable for your application.
- Installer must be a trained, experienced service technician.
- After installation is complete, check out product operation as provided in these instructions.



Electrical Shock or Equipment Damage Hazard. Can shock individuals or short equipment circuitry. Disconnect power supply before installation.

WIRING

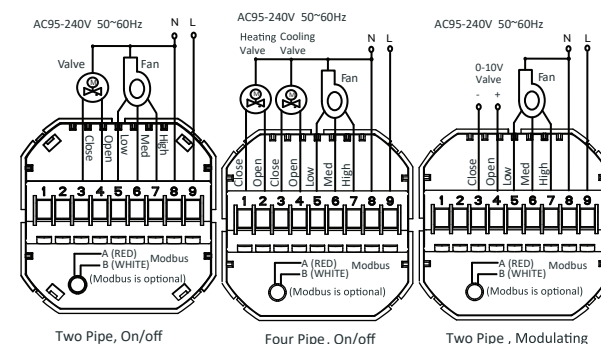

INSTALLATION

Your thermostat is suitable for installation within a standard 86mm pattress box or European 60mm pattress box.

Step 1. Keep the electricity off. See Fig 1.

Step 2. Remove the mounting Plate by rotating the LCD part. See Fig 2.

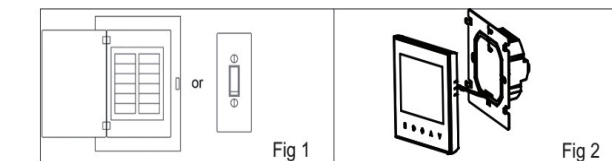

Step 3. Connect power supply, load into the appropriate terminals. (see "Wiring your thermostat" for details and Fig 3).

Step 4. Fix the mounting plate into the wall with screws in the box. See Fig 4.

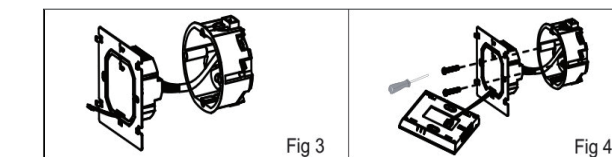

Step 5. Fasten body of thermostat and the mounting plate See Fig 5

Step 6. Installation complete. See Fig 6

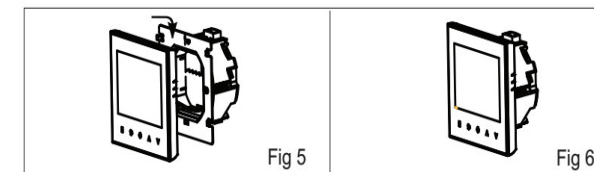

HOME SCREEN QUICK REFERENCE

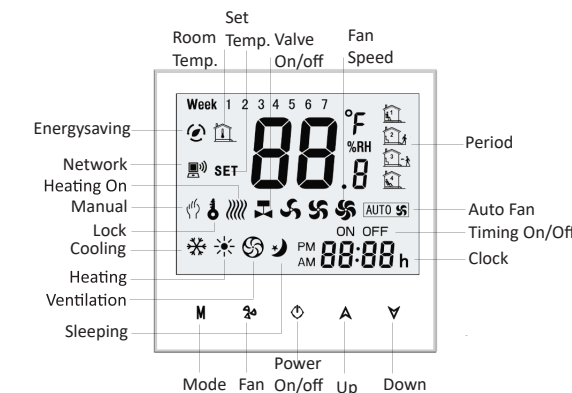

OPERATION

During Power On

- Power On/off:** Press to turn the thermostat on/off.
- Manual & Programmable:** Press and hold **M**, will flash. Press **A** to select manual and press to select weekly programmable.

3. Setting Temperature

In the mode of manual, press **A** to set temperature. will display in the left corner of screen.

4. Locking Your Thermostat

Press and hold the for 5 seconds to lock/unlock your thermostat. In item 3 of high senior options, you can select full lock or half lock.

5. Selecting System Mode

Press **M** to change the system mode HEATING, COOLING and VENTILATION. In the mode of VENTILATION, the valve is off but the fan runs.

6. Setting the Fan Speed

Press to select the fan speed AUTO, HIGH, MED, LOW.

7. Adjusting/Setting the Clock

Press and hold **M**, will flash. Press **M** to set minute, hour and weekday (1 = Monday, 2 = Tuesday etc.) by using the **A** arrows, after 3 seconds the value will be confirmed automatically.

8. Adjusting the Weekly Programmable

Press **M** to do the adjustment of weekly programmable. Then press **M** to change the different items. Press **A** or to set the relative values. Your thermostat provides six scheduled heating and cooling periods each day – three Comfort periods - 1, 3 & 5 (the temperature required when room is occupied) and three Economy periods – 2, 4 & 6 (the temperature required when room is unoccupied). You can set both the time and temperature for each of these six daily periods. Adjusting/setting the schedules can only be carried out when in program mode; Touch **M** (mode) to change between manual mode, and programme mode. In manual mode, will show in the bottom left of the screen. Touch the icon **M** for four times until the weekend schedule settings appear (1 2 3 4 5 will show along the top of the screen). Use the **A** and arrows to adjust the time for the 1st (Comfort) period Press the icon **M** and use the **A** and arrows to set the temp. for the 1st period. Repeat this process for periods 2 – 6. Press the icon **M** once more to enter the weekend schedule settings (6 & 7 will show along the top of the screen). Repeat the above process to set the weekend schedule. Press **M** once more to confirm and exit.

Default settings for program schedule

Time display	WEEKDAY (MONDAY – FRIDAY) (1 2 3 4 5 shows on screen)		WEEKEND (SATURDAY) (6 shows on screen)		WEEKEND (SUNDAY) (7 shows on screen)	
	TIME	TEMPERATURE	TIME	TEMPERATURE	TIME	TEMPERATURE
Period 1	06:00	20°C	06:00	20°C	06:00	20°C
Period 2	08:00	15°C	08:00	20°C	08:00	20°C
Period 3	11:30	15°C	11:30	20°C	11:30	20°C
Period 4	13:30	15°C	13:30	20°C	13:30	20°C
Period 5	17:00	22°C	17:00	20°C	17:00	20°C
Period 6	22:00	15°C	22:00	15°C	22:00	15°C

In the mode of programmable, set temp., time could not be adjusted.

During Power Off

Setting the Functions and Options

When power is off, press and hold **M** and at the same time for 5 sec. in order to reach system function. Then press **M** to change the different items. All the settings will confirm automatically when power is on.

Code	Function	Setting and options	Default
1	Temperature compensation	-9 to 9°C	-3
2	Fan control	00: When room temp. reaches the set point, the fan will turn off 01: When room temp. reaches the set point, the fan will turn to low speed	0
3	Button Locking	00: All buttons are locked except power button 01: All buttons are locked.	01
4	Heat/cool	00: Cool only 01: Heat/Cool	01
5	Min. Set Temp.	5 to 15°C	05
6	Max. Set Temp.	15 to 35°C	35
7	12/24 hours	00: 12h 01: 24h	01
8	Display Mode	00: Display both set temp. and room temp. 01: Display set temp. only	00
9	Modbus IP	1-255	01
A	Baudrate	1:9600 2:19200 3:38400 4:56000 5:115200	1
B	Dead Zone	1 to 5 (Switching differential)	1
C	Device Program	Version Number.	801

ABOUT WIFI

WI-FI CONNECTION

Before using your Wi-Fi thermostat for the first time, you must configure the Wi-Fi signal and settings through your smartphone or tablet, This will allow communication between your connected devices

Step 1 Download your APP (Fig1-1)



Fig 1-1



Fig 1-2 IOS



Fig 1-3 Android

Search for "Smartlife" in Apple Store or Google Play or use a browser to scan the QR code above (Figure 1-2), and complete account registration and installation according to the guidance of the APP.

Step 2. Connect the thermostat

Check the tutorial below to complete the connection and setup.

Method 1: Scan the QR code to configure the network guide (Fig 2.1-Fig 2.3)

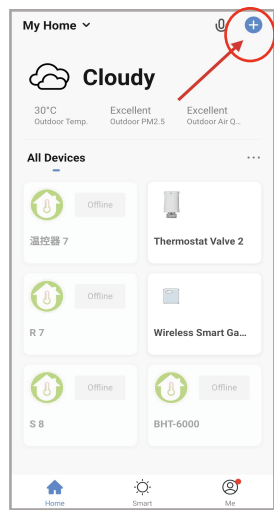

Fig2.1

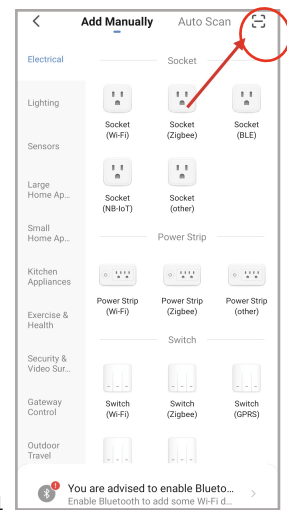

Fig2.2

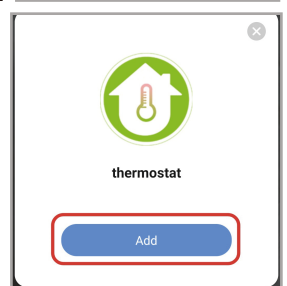

Fig2.3

Method 2: Ordinary distribution network guidance (Fig. 2. 1&Fig. 2.3.1)

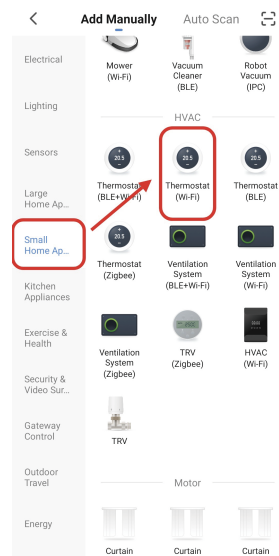

Fig2.3.1

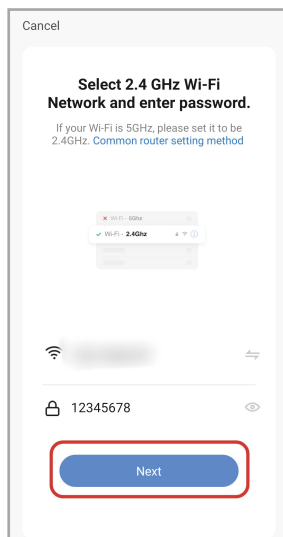

Fig2.5

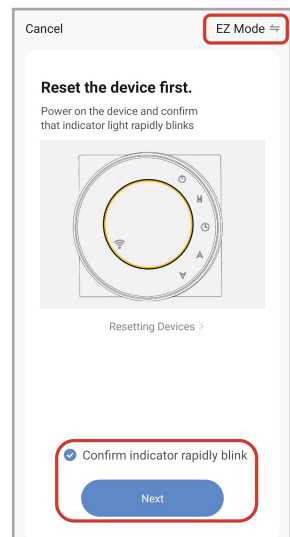

Fig2.4

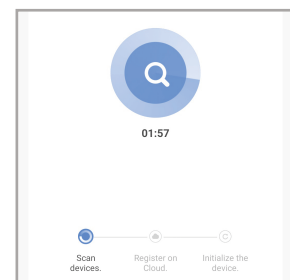

Fig2.6

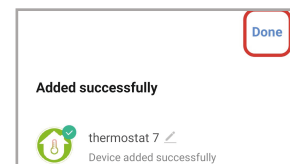

Fig2.7

Network distribution mode:

1、EZ Mode

When the thermostat is off, press and hold the "▽" until the thermostat screen flashes quickly and displays the "📶" icon, and then operate according to the following figure (Fig 2.4-Fig 2.7).

2、AP Mode

When the thermostat is off, press and hold the "▽" until the thermostat screen flashes slowly and the "📶" icon is displayed (if the "📶" icon appears, continue to press the "▽" until the thermostat screen Flashes slowly and displays the "📶" icon), and then operate according to the following figure (Fig 2.8-Fig 2.14).

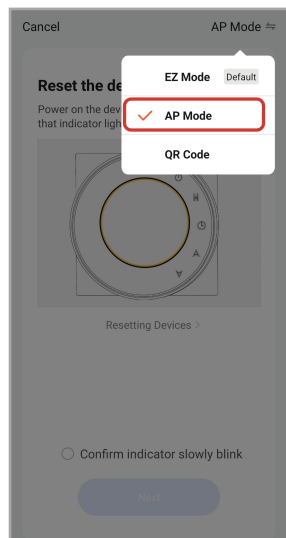

Fig2.8

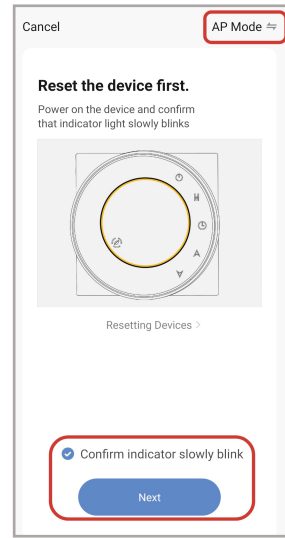

Fig2.9

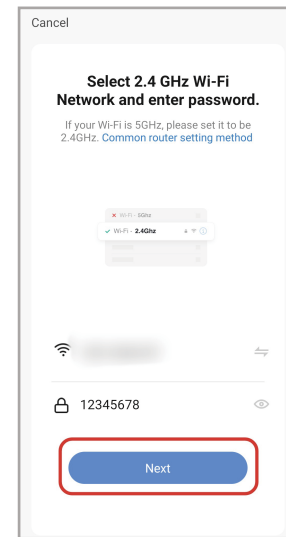

Fig2.10

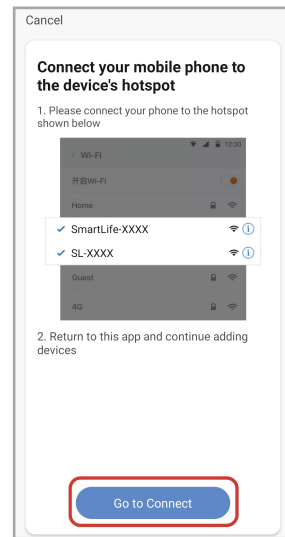

Fig2.11

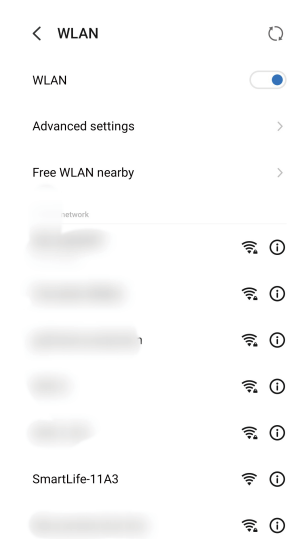

Fig2.12

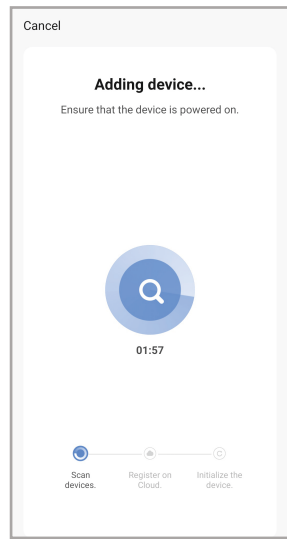

Fig2.13

After connecting to this hotspot, return to the "smartlife" APP

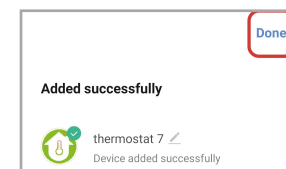
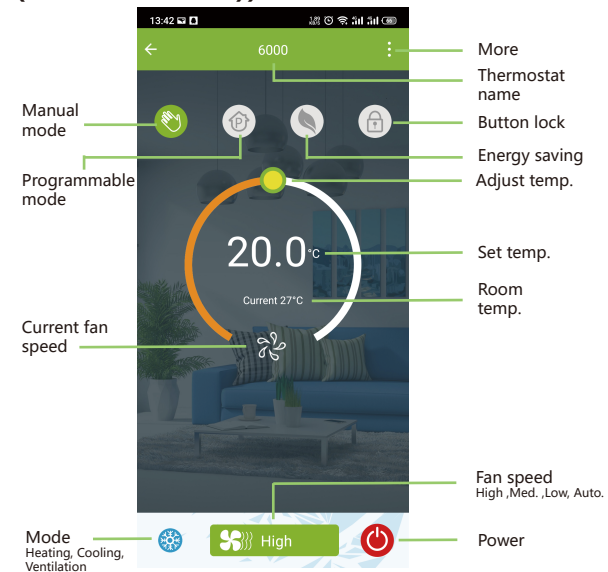
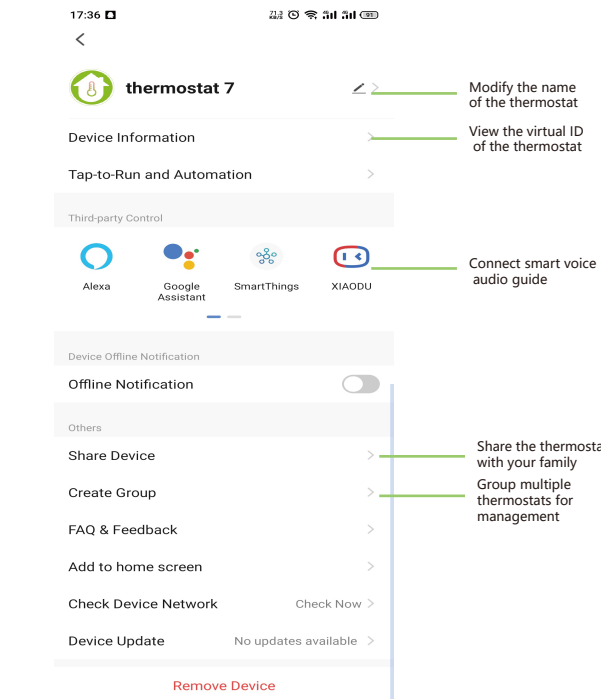

Fig2.14

APP operation interface description (FCU thermostat)



More settings



SIMPLE EXCEPTION HANDLING

No.	Phenomenons	Handling
1	Power is on but without display.	* Check if the terminals between LCD panel and Power Unit Box is loosen.
2	Without output but display works.	* Use a new LCD panel or new Power Unit Box to replace the old one.
3	Room Temp. Is a little different from the actual.	* Do temperature calibration in item 1 of high senior options

SERVICE

Your thermostat carries an 24 months warranty from date of purchase. Service outwith the warranty period may incur a charge. More detail please contact with us directly.



Scan this QR code

Thermostat Interface Protocol V1.0

This protocol takes standard Modbus as a reference, mainly for use for communication between thermostat and computer (PC). This protocol doesn't describe Modbus. For information about Modbus, please refer to the relevant standard documents.

Settings

1. Basic description

No	Parameter	Protocol provision
1	Operating mode	RS-485, master-slave : thermostat is the slave machine
2	Physical interface	A(+), B(-) two-wire system
3	Baud rate	9600 bps (standard)
4	Byte format	9 format (8 data bits +1 stop bit)
5	Modbus	RTU
6	Transmission mode	RTU format (Please refer to standard Modbus)
7	Thermostat address	1—255 : (0 is broadcast address)
8	Command code	03, 06, and 16 (03—read thermostat, 06—set thermostat, 16—set thermostat for several bytes)
9	CRC check code	CRC—16 (Please refer to standard Modbus)
10	CRC verification mode	CRC—16 (Please refer to standard Modbus)

2. Read the thermostat frame format

Byte 1	Byte 2	Byte 3	Byte 4	Byte 5	Byte 6	Byte 7	Byte 8
Thermostat address (default is 0X01)	03	Set register start address high byte	Set register start address low byte	Set register Value high address	Set register Value low address	CRC high	CRC low

Command	Byte	Description	Register address
03	High Byte	00	40001
	Low Byte	Setting Power On/off: 0—means closed, 1—means open	
	High Byte	00	40002
	Low Byte	Setting Fan Speed: 0 - Auto speed; 1 - High speed; 2- Mid speed; 3-Low speed:	
	High Byte	00	40003
	Low Byte	Setting Mode: 0—Cooling; 1—Heating; 2 - Ventilation	
	High Byte	00	40004
	Low Byte	Setting Temp. * 10	
	High Byte	00	40005
	Low Byte	Setting Lock: 0 - Unlock; 1 - Lock	
	High Byte	00	40006
	Low Byte	Manual/Programmable:0-Programmable;1-Manual	
	High Byte	00	40007
	Low Byte	Minute (value 1-59)	
	High Byte	00	40008
	Low Byte	Hour (value 0-23)	
High Byte	00	40009	
Low Byte	Week (value 1-7), 1-Monday, 2-Tuesday, 3-Wednesday, 4- Thursday, 5- Friday, 6- Saturday, 7- Sunday		
High Byte	00	40010	
Low Byte	Reading Room Temperature: * 10		
High Byte	00	40011	
Low Byte	Valve On=1 Valve off=0		
High Byte	00	40012	
Low Byte	Fan Status: 1 - High speed; 2- Mid speed; 3- Low speed 0-OFF		

3. Set the thermostat frame format

Byte 1	Byte 2	Byte 3	Byte 4	Byte 5	Byte 6	Byte 7	Byte 8
Thermostat address (default is 0X01)	03	Set register start address high byte	Set register start address low byte	Set register Value high address	Set register Value low address	CRC high	CRC low

Command	Byte	Description	Register address
06	High Byte	00	40001
	Low Byte	Setting Power On/off: 0—means closed, 1—means open	
	High Byte	00	40002
	Low Byte	Setting Fan Speed: 0 - Auto speed; 1 - High speed; 2- Mid speed; 3-Low speed:	
	High Byte	00	40003
	Low Byte	Setting Mode: 0—Cooling; 1—Heating; 2 - Ventilation	
	High Byte	00	40004
	Low Byte	Setting Temp. * 10	
	High Byte	00	40005
	Low Byte	Setting Lock: 0 - Unlock; 1 - Lock	
	High Byte	00	40006
	Low Byte	Manual/Programmable:0-Programmable;1-Manual	
	High Byte	00	40007
	Low Byte	Minute (value 1-59)	
	High Byte	00	40008
	Low Byte	Hour (value 0-23)	
High Byte	00	40009	
Low Byte	Week (value 1-7), 1-Monday, 2-Tuesday, 3-Wednesday, 4- Thursday, 5- Friday, 6- Saturday, 7- Sunday		

4. Continuous Multi-byte set the thermostat frame format

Byte 1	Byte 2	Byte 3	Byte 4	Byte 5	Byte 6	Byte 7	Byte N-1	Byte N
Thermostat address (default is 0X01)	16(0x10)	Set register start address high byte	Set register start address low byte	Set register Number N* 2	Set register Value high address	Set register Value low address	N set byte value high address	N set byte value low address

Byte N+1	Byte N+2
CRC high	CRC low

Command	Byte	Description	Register address
16 (0x10)	High Byte	00	40001
	Low Byte	Setting Power On/off: 0—means closed, 1—means open	
	High Byte	00	40002
	Low Byte	Setting Fan Speed: 0 - Auto speed; 1 - High speed; 2- Mid speed; 3-Low speed:	
	High Byte	00	40003
	Low Byte	Setting Mode: 0—Cooling; 1—Heating; 2 - Ventilation	
	High Byte	00	40004
	Low Byte	Setting Temp. * 10	
	High Byte	00	40005
	Low Byte	Setting Lock: 0 - Unlock; 1 - Lock	
	High Byte	00	40006
	Low Byte	Manual/Programmable:0-Programmable;1-Manual	
	High Byte	00	40007
	Low Byte	Minute (value 1-59)	
	High Byte	00	40008
	Low Byte	Hour (value 0-23)	
High Byte	00	40009	
Low Byte	Week (value 1-7), 1-Monday, 2-Tuesday, 3-Wednesday, 4- Thursday, 5- Friday, 6- Saturday, 7- Sunday		

Remark

1. Format

When the thermostat sends collected temperature data to the PC computer, the value of collected temperature should be multiplied by 10.

For example: **When the collected temperature is 25.5°C**, the value sent from the thermostat to the PC computer will be 255.



Similarly, when the PC computer sends set temperature data to the thermostat, the value of the set temperature should be multiplied by 10.

For example: **When the set temperature is 25.5°C**, the value sent from the PC computer to the thermostat should be 255.

2. How to change the thermostat's IP address?

During power off, press **M** and  at the same time for 5 seconds to access system functions.

Press **M** till you reach item A.

Then press  and  to change the relative value. The default is 0x01.

Turn on your thermostat to save the IP setting.