

- Air damper size up to approx. 3 m<sup>2</sup>
- Actuating force 450 N
- Nominal voltage AC/DC 24 V
- Control modulating, communicative 2...10 V variable
- Position feedback 2...10 V variable
- Length of Stroke Max. 100 mm, adjustable in 20 mm increments
- Conversion of sensor signals
- Communication via Belimo MP-Bus

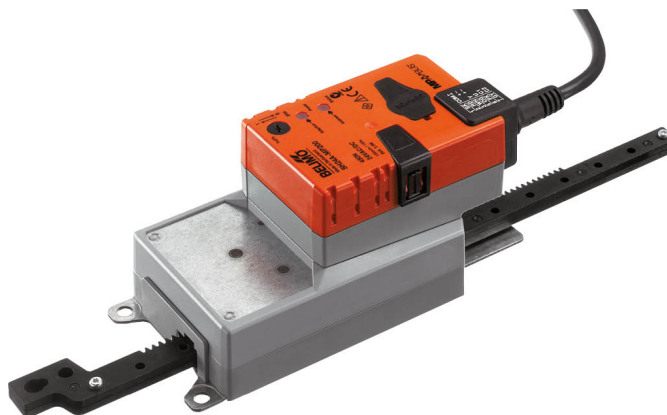

### Technical data

<b>Electrical data</b>	Nominal voltage	AC/DC 24 V
	Nominal voltage frequency	50/60 Hz
	Nominal voltage range	AC 19.2...28.8 V / DC 21.6...28.8 V
	Power consumption in operation	3.5 W
	Power consumption in rest position	1.4 W
	Power consumption for wire sizing	6 VA
	Connection supply / control	Cable 1 m, 4 x 0.75 mm <sup>2</sup>
	Parallel operation	Yes (note the performance data)
<b>Functional data</b>	Actuating force motor	450 N
	Actuating force variable	25%, 50%, 75% reduziert
	Communicative control	MP-Bus
	Operating range Y	2...10 V
	Input Impedance	100 kΩ
	Operating range Y variable	Start point 0.5...30 V End point 2.5...32 V
	Options positioning signal	Open/close 3-point (AC only) Modulating (DC 0...32 V)
	Position feedback U	2...10 V
	Position feedback U note	Max. 0.5 mA
	Position feedback U variable	Start point 0.5...8 V End point 2.5...10 V
	Position accuracy	±5%
	Direction of motion motor	selectable with switch
	Direction of motion note	Y = 0 V: with switch 0 (retracted) / 1 (extended)
	Direction of motion variable	electronically reversible
	Manual override	with push-button, can be locked
	Stroke	100 mm
	Length of Stroke	Max. 100 mm, adjustable in 20 mm increments
	Stroke limitation	can be limited on both sides with mechanical end stops
	Running time motor	150 s / 100 mm
	Running time motor variable	150...600 s / 100 mm
Adaptation setting range	manual	
Adaptation setting range variable	No action Adaptation when switched on Adaptation after pushing the gear disengagement button	
Override control	MAX (maximum position) = 100% MIN (minimum position) = 0% ZS (intermediate position, AC only) = 50%	

	Override control variable	MAX = (MIN + 32%)...100% MIN = 0%...(MAX – 32%) ZS = MIN...MAX
	Sound power level, motor	52 dB(A)
<b>Safety data</b>	Protection class IEC/EN	III Safety Extra-Low Voltage (SELV)
	Protection class UL	UL Class 2 Supply
	Degree of protection IEC/EN	IP54
	Degree of protection NEMA/UL	NEMA 2
	Enclosure	UL Enclosure Type 2
	EMC	CE according to 2014/30/EU
	Certification IEC/EN	IEC/EN 60730-1 and IEC/EN 60730-2-14
	Certification UL	cULus according to UL60730-1A, UL60730-2-14 and CAN/CSA E60730-1:02
	Certification UL note	The UL marking on the actuator depends on the production site, the device is UL-compliant in any case
	Mode of operation	Type 1
	Rated impulse voltage supply / control	0.8 kV
	Control pollution degree	3
	Ambient temperature	-30...50°C
	Storage temperature	-40...80°C
Ambient humidity	Max. 95% r.H., non-condensing	
Servicing	maintenance-free	
<b>Weight</b>	Weight	1.1 kg

**Safety notes**

- The device must not be used outside the specified field of application, especially not in aircraft or in any other airborne means of transport.
- Outdoor application: only possible in case that no (sea) water, snow, ice, insulation or aggressive gases interfere directly with the device and that it is ensured that the ambient conditions remain within the thresholds according to the data sheet at any time.
- Only authorised specialists may carry out installation. All applicable legal or institutional installation regulations must be complied during installation.
- The device may only be opened at the manufacturer's site. It does not contain any parts that can be replaced or repaired by the user.
- Cables must not be removed from the device.
- The rotary supports and coupling pieces available as accessories and must always be used if transverse forces are likely. In addition, the actuator must not be tightly bolted to the application. It must remain movable via the rotary support (refer to «Installation notes»).
- If the actuator is exposed to severely contaminated ambient air, appropriate precautions must be taken on the system side. Excessive deposits of dust, soot etc. can prevent the gear rod from being extended and retracted correctly.
- If not installed horizontally, the gear disengagement push-button may only be actuated when there is no pressure on the gear rod.
- To calculate the actuating force required for air dampers and slide valves, the specifications supplied by the damper manufacturers concerning the cross section, the design, the installation site and the ventilation conditions must be observed.
- If a rotary support and/or coupling piece is used, actuation force losses are to be expected.
- The device contains electrical and electronic components and must not be disposed of as household refuse. All locally valid regulations and requirements must be observed.

**Product features**

**Mode of operation** Conventional operation:

The actuator is connected with a standard modulating signal of 0...10 V and drives to the position defined by the positioning signal. Measuring voltage U serves for the electrical display of the damper position 0.5...100% and as slave control signal for other actuators.

**Operation on Bus:**

The actuator receives its digital positioning signal from the higher level controller via the MP-Bus and drives to the position defined. Connection U serves as communication interface and does not supply an analogue measuring voltage.

The actuator has a seal closing function. The mechanical end stop is actively approached as soon as the control signal < DC 2.1 V or > DC 9.9 V. As soon as the control signal is again > DC 2.2 V or < DC 9.8 V, the actuator drives to the position defined by the positioning signal in the adapted range.

- Converter for sensors** Connection option for a sensor (passive or active sensor or switching contact). The MP actuator serves as an analogue/digital converter for the transmission of the sensor signal via MP-Bus to the higher level system.
- Configurable actuators** The factory settings cover the most common applications. Single parameters can be modified with the Belimo Service Tools MFT-P or ZTH EU.
- Simple direct mounting** The actuator can be directly connected with the application using the enclosed screws. The head of the gear rod is connected to the moving part of the ventilating application individually on the mounting side or with the Z-KS1 coupling piece provided for this purpose.
- Manual override** Manual override with push-button possible (the gear is disengaged for as long as the button is pressed or remains locked).
- Adjustable stroke** If a stroke limitation will be adjusted, the operating range on this side of the gear rod can be used starting with an extension length of 20 mm and then can be limited respectively in increments of 20 mm by means of the mechanical end stops Z-AS1.
- High functional reliability** The actuator is overload protected, requires no limit switches and automatically stops when the end stop is reached.
- Home position** The first time the supply voltage is switched on, i.e. at the time of commissioning, the actuator carries out a synchronisation. The synchronisation is in the home position (0%).

The actuator then moves into the position defined by the positioning signal.

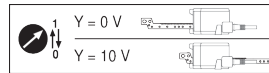

- Adaptation and synchronisation** An adaption can be triggered manually by pressing the "Adaption" button or with the PC-Tool. Both mechanical end stops are detected during the adaption (entire setting range).  
Automatic synchronisation after pressing the gearbox disengagement button is configured. The synchronisation is in the home position (0%).  
The actuator then moves into the position defined by the positioning signal.  
A range of settings can be adapted using the PC-Tool (see MFT-P documentation)

**Accessories**

Gateways	Description	Type
	Gateway MP zu BACnet MS/TP	UK24BAC
	Gateway MP to KNX	UK24EIB
	Gateway MP to Modbus RTU	UK24MOD
Electrical accessories	Description	Type
	Positioner for wall mounting	CRP24-B1 EXT-WR-FP20-MP
	Positioner for wall mounting	SGA24
	Positioner for built-in mounting	SGE24
	Positioner for front-panel mounting	SGF24
	Signal converter voltage/current 100 kΩ Supply AC/DC 24 V	Z-UIC
	Connection cable 5 m, A: RJ11 6/4 ZTH EU, B: 6-pin for connection to service socket	ZK1-GEN
	Connection cable 5 m, A: RJ11 6/4 ZTH EU, B: free wire end for connection to MP/PP terminal	ZK2-GEN
	MP-Bus power supply for MP actuators	ZN230-24MP

Mechanical accessories	Description	Type
	End stop kit, Multipack 20 pcs.	Z-AS1
	Rotary support, for linear actuator, for compensation of transverse forces	Z-DS1
	Coupling piece M8	Z-KS1
Service tools	Description	Type
	Adapter for Service-Tool ZTH	MFT-C
	Belimo PC-Tool, Software for adjustments and diagnostics	MFT-P
	Service Tool, with ZIP-USB function, for configurable and communicative Belimo actuators, VAV controller and HVAC performance devices	ZTH EU

### Electrical installation



Supply from isolating transformer.

Parallel connection of other actuators possible. Observe the performance data.

#### Wiring diagrams

AC/DC 24 V, modulating

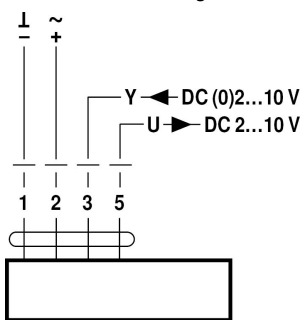

Cable colours:

- 1 = black
- 2 = red
- 3 = white
- 5 = orange

Operation on the MP-Bus

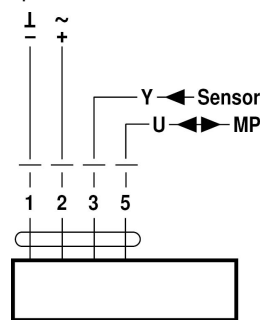

Cable colours:

- 1 = black
- 2 = red
- 3 = white
- 5 = orange

### Functions

#### Functions when operated on MP-Bus

Connection on the MP-Bus

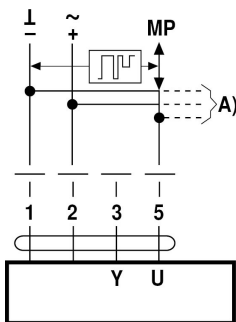

A) additional MP-Bus nodes (max. 8)

MP-Bus Network topology

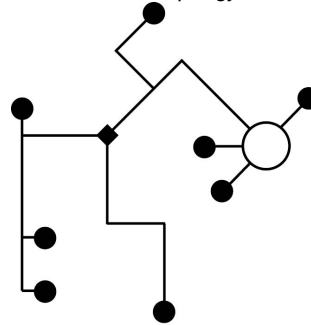

There are no restrictions for the network topology (star, ring, tree or mixed forms are permitted).

Supply and communication in one and the same 3-wire cable

- no shielding or twisting necessary
- no terminating resistors required

Connection of active sensors

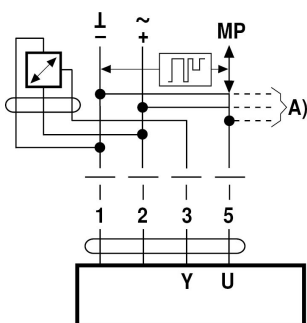

- A) additional MP-Bus nodes (max. 8)
- Supply AC/DC 24 V
  - Output signal DC 0...10 V (max. DC 0...32 V)
  - Resolution 30 mV

Connection of external switching contact

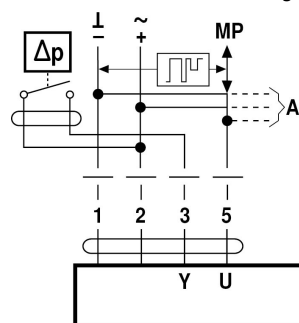

- A) additional MP-Bus nodes (max. 8)
- Switching current 16 mA @ 24 V
  - Start point of the operating range must be parametrised on the MP actuator as  $\geq 0.5$  V

Connection of passive sensors

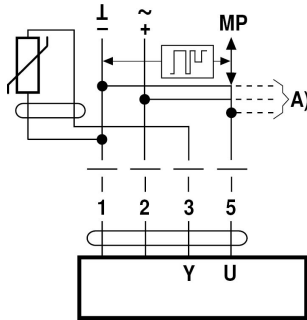

Ni1000	-28...+98 °C	850...1600 Ω <sup>2)</sup>
PT1000	-35...+155 °C	850...1600 Ω <sup>2)</sup>
NTC	-10...+160 °C <sup>1)</sup>	200 Ω...60 kΩ <sup>2)</sup>

- A) additional MP-Bus nodes (max. 8)  
 1) Depending on the type  
 2) Resolution 1 Ohm

Functions with basic values (conventional mode)

Override control with AC 24 V with relay contacts

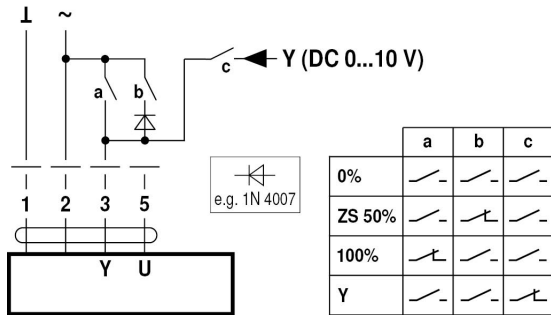

Override control with AC 24 V with rotary switch

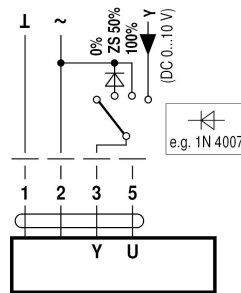

Control remotely 0...100% with positioner SG..

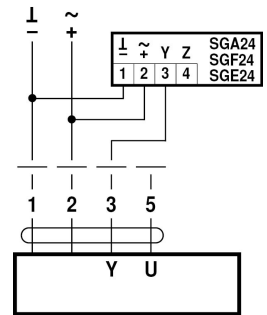

Minimum limit with positioner SG..

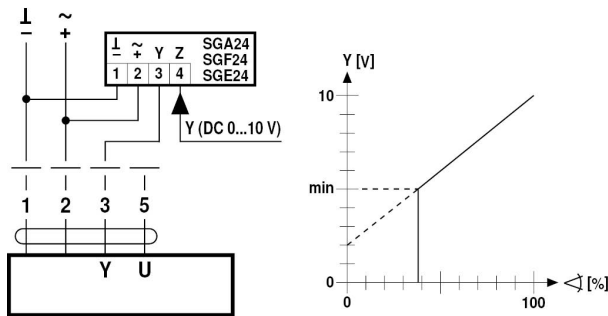

Follow-up control (position-dependent)

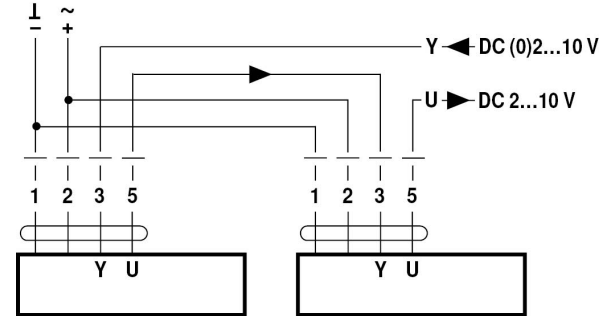

Control with 4...20 mA via external resistor

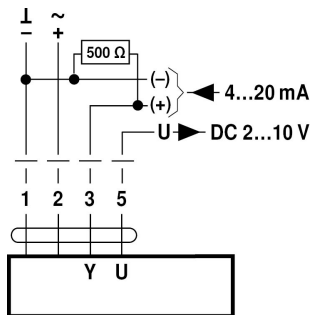

**Caution:**  
 The operating range must be set to DC 2...10 V.  
 The 500 Ω resistor converts the 4...20 mA current signal to a voltage signal DC 2...10 V

Functional check

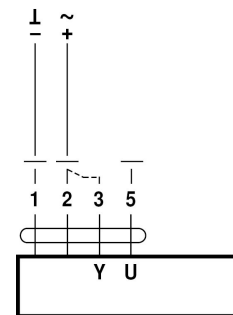

- Procedure**
1. Apply 24 V to connection 1 and 2
  2. Disconnect connection 3:
    - for direction of stroke 0: Actuator travels in the direction "retracted"
    - for direction of stroke 1: Actuator travels in the direction "extended"
  3. Short circuit connections 2 and 3:
    - Actuator runs in the opposite direction

Functions for actuators with specific parameters (Parametrisation necessary)

Override control and limiting with AC 24 V with relay contacts

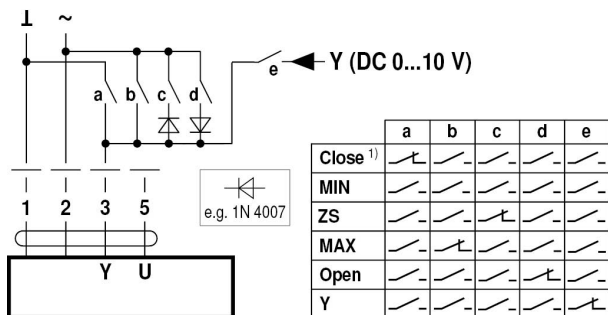

Override control and limiting with AC 24 V with rotary switch

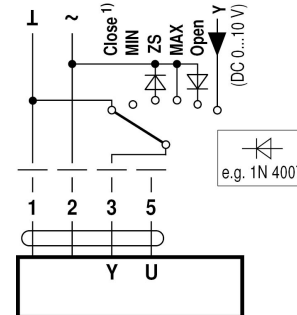

- 1) **Caution:** This function is only guaranteed if the start point of the operating range is defined as min. 0.5 V.

Control open/close

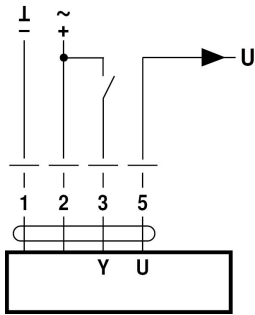

Control 3-point

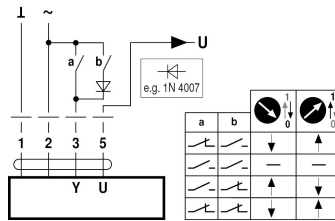

**Operating controls and indicators**

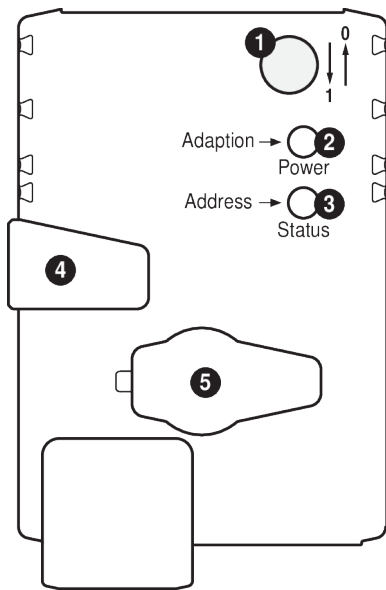

- 1 Direction of stroke switch**  
Switch over: Direction of stroke changes
  - 2 Push-button and LED display green**  
Off: No power supply or malfunction  
On: In operation  
Press button: Triggers stroke adaptation, followed by standard mode
  - 3 Push-button and LED display yellow**  
Off: Standard mode  
Flickering: MP communication active  
On: Adaptation or synchronising process active  
Flashing: Request for addressing from MP master  
Press button: Confirmation of the addressing
  - 4 Gear disengagement button**  
Press button: Gear disengages, motor stops, manual override possible  
Release button: Gear engages, synchronisation starts, followed by standard mode
  - 5 Service plug**  
For connecting parameterisation and service tools
- Check power supply connection**
- 2** Off and **3** On Possible wiring error in power supply

**Installation notes**



**If a rotary support and/or coupling piece is used, losses in the actuation force losses are to be expected.**

**Applications without transverse forces**

The linear actuator is screwed directly to the housing at three points. Afterwards, the head of the gear rod is fastened to the moving part of the ventilation application (e.g. damper or slide valve).

**Applications with transverse forces**

The coupling piece with the internal thread (Z-KS1) is connected to the head of the gear rod. The rotary support (Z-DS1) is screwed to the ventilation application. Afterwards, the linear actuator is screwed to the previously mounted rotary support with the enclosed screw. Afterwards, the coupling piece, which is mounted to the head of the gear rod, is attached to the moving part of the ventilating application (e.g. damper or slide valve). The transverse forces can be compensated for to a certain limit with the rotary support and/or coupling piece. The maximum permissible swivel angle of the rotary support and coupling piece is 10° (angle), laterally and upwards.

**Service**

**Service Tools connection**

The actuator can be parametrised by ZTH EU via the service socket.  
For an extended parametrisation the PC tool can be connected.

Connection ZTH EU / PC-Tool

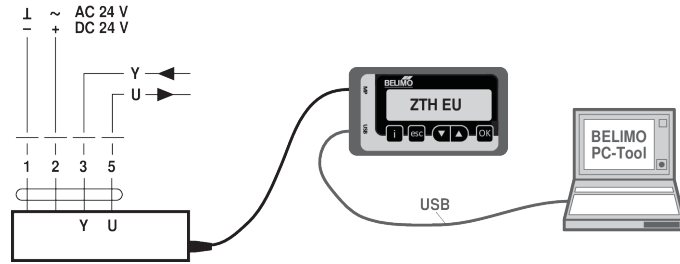

Dimensions

Dimensional drawings

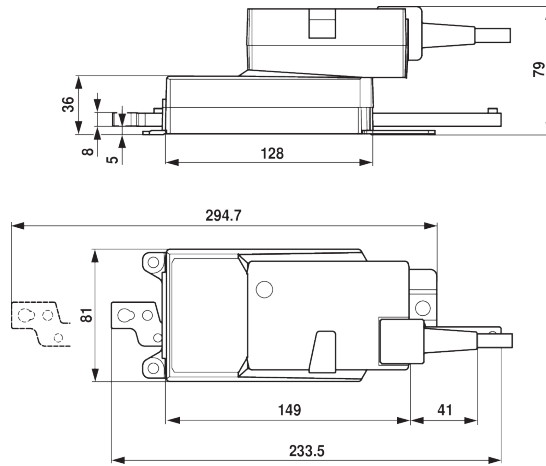

Further documentation

- Overview MP Cooperation Partners
- Tool connections
- Introduction to MP-Bus Technology

Application notes

- For digital control of actuators in VAV applications patent EP 3163399 must be considered.