

- Torque motor 20 Nm
- Nominal voltage AC/DC 24 V
- Control modulating, communicative, hybrid
- Conversion of sensor signals
- Communication via BACnet MS/TP, Modbus RTU, Belimo-MP-Bus or conventional control



### Technical data

<b>Electrical data</b>	Nominal voltage	AC/DC 24 V
	Nominal voltage frequency	50/60 Hz
	Nominal voltage range	AC 19.2...28.8 V / DC 21.6...28.8 V
	Power consumption in operation	3.5 W
	Power consumption in rest position	1.25 W
	Power consumption for wire sizing	6 VA
	Connection supply / control	Cable 1 m, 6 x 0.75 mm <sup>2</sup>
<b>Functional data</b>	Torque motor	20 Nm
	Torque variable	25%, 50%, 75% reduced
	Communicative control	BACnet MS/TP Modbus RTU (default setting) MP-Bus
	Operating range Y	2...10 V
	Operating range Y variable	0.5...10 V
	Position feedback U	2...10 V
	Position feedback U note	Max. 1 mA
	Position feedback U variable	Start point 0.5...8 V End point 2...10 V
	Position accuracy	±5%
	Manual override	with push-button, can be locked
	Running time motor	90 s / 90°
	Running time motor variable	90...350 s
	Adaptation setting range	manual (automatic on first power-up)
	Adaptation setting range variable	No action Adaptation when switched on Adaptation after pushing the gear disengagement button
	Override control, controllable via bus communication	MAX (maximum position) = 100% MIN (minimum position) = 0% ZS (intermediate position) = 50%
	Override control variable	MAX = (MIN + 33%)...100% MIN = 0%...(MAX - 33%) ZS = MIN...MAX
	Sound power level, motor	45 dB(A)
Position indication	Mechanically, pluggable	
<b>Safety data</b>	Protection class IEC/EN	III Safety Extra-Low Voltage (SELV)
	Protection class UL	UL Class 2 Supply
	Degree of protection IEC/EN	IP54
	Degree of protection NEMA/UL	NEMA 2 UL Enclosure Type 2
EMC	CE according to 2014/30/EU	

Certification IEC/EN	IEC/EN 60730-1 and IEC/EN 60730-2-14
Certification UL	cULus according to UL60730-1A, UL60730-2-14 and CAN/CSA E60730-1:02 The UL marking on the actuator depends on the production site, the device is UL-compliant in any case
Mode of operation	Type 1
Rated impulse voltage supply / control	0.8 kV
Control pollution degree	3
Ambient temperature	-30...50°C
Storage temperature	-40...80°C
Ambient humidity	Max. 95% r.H., non-condensing
Servicing	maintenance-free
<b>Weight</b>	<b>Weight</b> 0.96 kg

**Safety notes**

- This device has been designed for use in stationary heating, ventilation and air-conditioning systems and must not be used outside the specified field of application, especially in aircraft or in any other airborne means of transport.
- Outdoor application: only possible in case that no (sea) water, snow, ice, insulation or aggressive gases interfere directly with the device and that it is ensured that the ambient conditions remain within the thresholds according to the data sheet at any time.
- Only authorised specialists may carry out installation. All applicable legal or institutional installation regulations must be complied during installation.
- The switch for changing the direction of rotation may only be operated by authorised specialists. The direction of rotation must not in particular be reversed in a frost protection circuit.
- The device may only be opened at the manufacturer's site. It does not contain any parts that can be replaced or repaired by the user.
- Cables must not be removed from the device.
- The device contains electrical and electronic components and must not be disposed of as household refuse. All locally valid regulations and requirements must be observed.

**Product features**

<b>Mode of operation</b>	The actuator is fitted with an integrated interface for BACnet MS/TP, Modbus RTU and MP-Bus. It receives the digital positioning signal from the control system and returns the current status.
<b>Converter for sensors</b>	Connection option for a sensor (passive, active or with switching contact). In this way, the analogue sensor signal can be easily digitised and transferred to the bus systems : BACnet, Modbus or MP-Bus.
<b>Configurable actuators</b>	The factory settings cover the most common applications. Single parameters can be modified with the Belimo Service Tools MFT-P or ZTH EU. The communication parameters of the bus systems (address, baud rate etc.) are set with the ZTH EU. Pressing the "Address" button on the actuator while connecting the supply voltage, resets the communication parameters to the factory setting. Quick addressing: The BACnet and Modbus address can alternatively be set using the buttons on the actuator and selecting 1...16. The value selected is added to the «Basic address» parameter and results in the effective BACnet and Modbus address.
<b>Combination analogue - communicative (hybrid mode)</b>	With conventional control by means of an analogue positioning signal, BACnet or Modbus can be used for the communicative position feedback
<b>Simple direct mounting</b>	Straightforward direct mounting on the ball valve with only one central screw. The assembly tool is integrated in the plug-in position indication. The mounting orientation in relation to the ball valve can be selected in 90° steps.
<b>Manual override</b>	Manual override with push-button possible (the gear is disengaged for as long as the button is pressed or remains locked).
<b>Adjustable angle of rotation</b>	Adjustable angle of rotation with mechanical end stops.

- High functional reliability** The actuator is overload protected, requires no limit switches and automatically stops when the end stop is reached.
- Home position** The first time the supply voltage is switched on, i.e. at the time of commissioning, the actuator carries out an adaption, which is when the operating range and position feedback adjust themselves to the mechanical setting range.  
The actuator then moves into the position defined by the positioning signal.  
Factory setting: Y2 (counter-clockwise rotation).
- Adaptation and synchronisation** An adaption can be triggered manually by pressing the "Adaption" button or with the PC-Tool. Both mechanical end stops are detected during the adaption (entire setting range).  
Automatic synchronisation after pressing the gearbox disengagement button is configured. The synchronisation is in the home position (0%).  
The actuator then moves into the position defined by the positioning signal.  
A range of settings can be adapted using the PC-Tool (see MFT-P documentation)

**Accessories**

Electrical accessories	Description	Type
	Connection cable 5 m, A: RJ11 6/4 ZTH EU, B: 6-pin for connection to service socket	ZK1-GEN
	Connection cable 5 m, A: RJ11 6/4 ZTH EU, B: free wire end for connection to MP/PP terminal	ZK2-GEN
Service tools	Description	Type
	Adapter for Service-Tool ZTH	MFT-C
	Belimo PC-Tool, Software for adjustments and diagnostics	MFT-P
	Service Tool, with ZIP-USB function, for parametrisable and communicative Belimo actuators, VAV controller and HVAC performance devices	ZTH EU

**Electrical installation**

**Supply from isolating transformer.**

The wiring of the line for BACnet MS/TP / Modbus RTU is to be carried out in accordance with applicable RS485 regulations.

**Modbus / BACnet: Supply and communication are not galvanically isolated. Connect earth signal of the devices with one another.**

**Wiring diagrams**

BACnet MS/TP / Modbus RTU

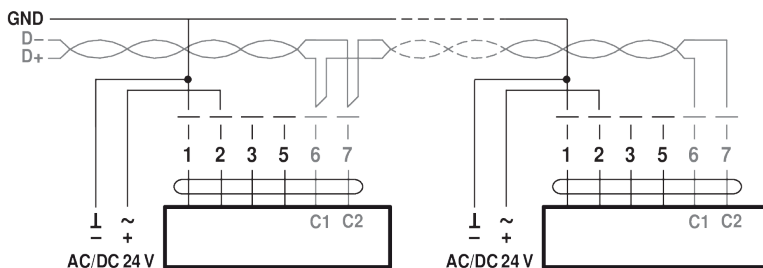
**Cable colours:**

- 1= black
  - 2 = red
  - 3 = white
  - 5 = orange
  - 6 = pink
  - 7 = grey
- BACnet / Modbus signal assignment:  
C1 = D- = A  
C2 = D+ = B

Connection with passive sensor, e.g. Pt1000, Ni1000, NTC

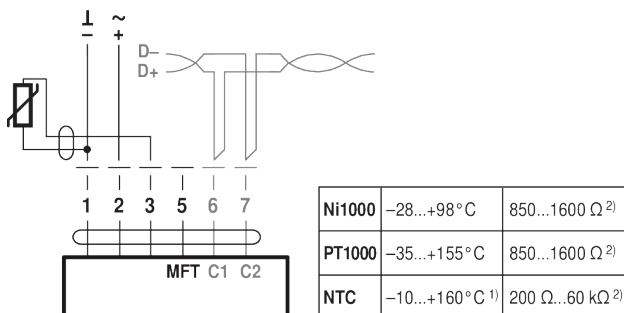

- 1) depending on type
- 2) Resolution 1 Ohm

Connection with active sensor, e.g. 0...10 V @ 0...50°C

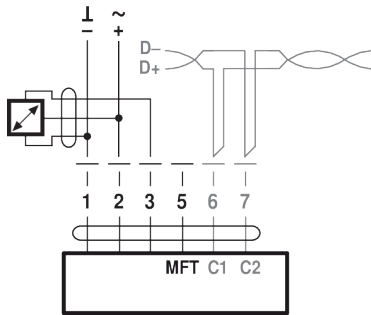

Possible voltage range:  
0...32 V (resolution 30 mV)

Connection with switching contact, e.g.  $\Delta p$  monitor

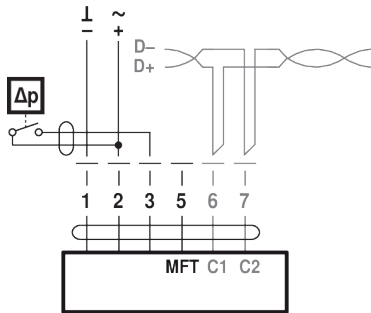

Requirements for switching contact:  
The switching contact must be able to accurately switch a current of 16 mA @ 24 V.

Modbus RTU / BACnet MS/TP with analogue setpoint (hybrid mode)

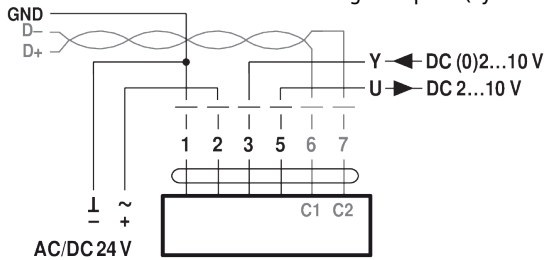

Operation on the MP-Bus

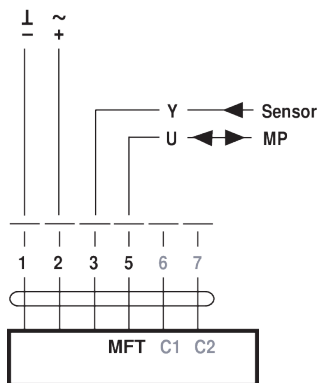

### Operating controls and indicators

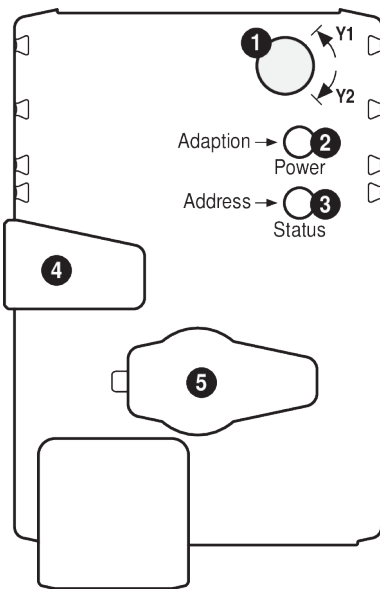
**1 Direction of rotation switch**

Switch over: Direction of rotation changes

**2 Push-button and LED display green**

Off: No power supply or malfunction

On: In operation

Flashing: In address mode: Pulses according to set address (1...16)

When starting: Reset to factory setting (Communication)

Press button: In standard mode: Triggers angle of rotation adaptation

In address mode: Confirmation of set address (1...16)

**3 Push-button and LED display yellow**

Off: Standard mode

On: Adaptation or synchronising process active or actuator in address mode (LED display green flashing)

Flickering: BACnet / Modbus communication active

Press button: In operation (>3 s): Switch address mode on and off

In address mode: Address setting by pressing several times

When starting (>5 s): Reset to factory setting (Communication)

**4 Gear disengagement button**

Press button: Gear disengages, motor stops, manual override possible

Release button: Gear engages, synchronisation starts, followed by standard mode

**5 Service plug**

For connecting parameterisation and service tools

**Check power supply connection**

**2** Off and **3** On Possible wiring error in power supply

**Service**
**Quick addressing**

1. Press the "Address" button until the green "Power" LED is no longer illuminated. LED flashes in accordance with the previously set address.
2. Set the address by pressing the "Address" button the corresponding number of times (1...16).
3. The green LED flashes in accordance with the address that has been entered (...16). If the address is not correct, then this can be reset in accordance with Step 2.
4. Confirm the address setting by pressing the green "Adaption" button.

If no confirmation occurs for 60 seconds, then the address procedure is ended. Any address change that has already been started will be discarded.

The resulting BACnet MS/TP and Modbus RTU address is made up of the set basic address plus the short address (e.g. 100+7=107).

**Service Tools connection**

The actuator can be parametrised by ZTH EU via the service socket.

For an extended parametrisation the PC tool can be connected.

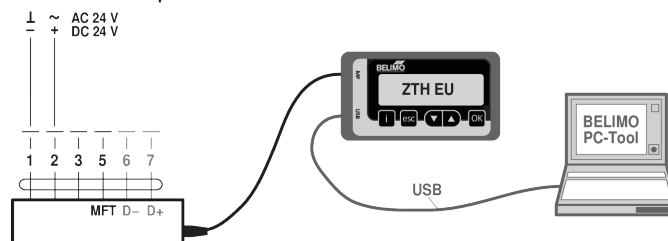
**Dimensions**

## Dimensional drawings

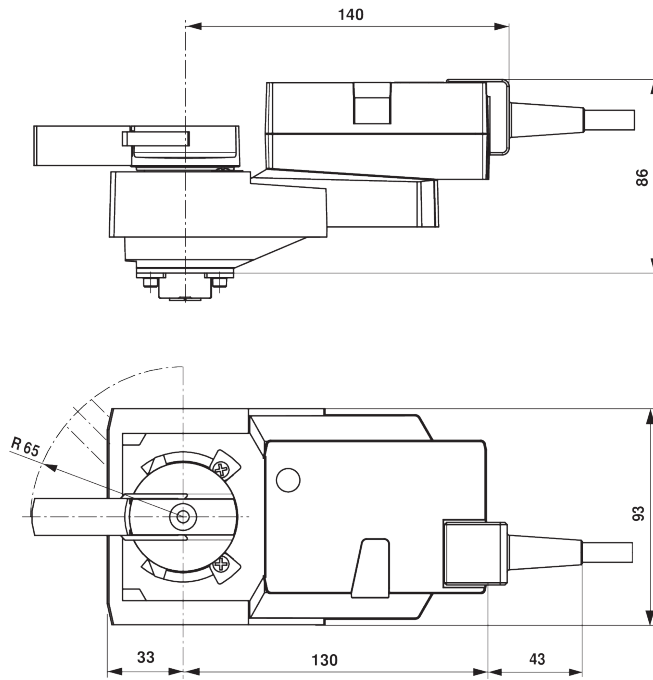

## Further documentation

- Tool connections
- Description Protocol Implementation Conformance Statement PICS
- Description Modbus register
- Overview MP Cooperation Partners
- MP Glossary
- Introduction to MP-Bus Technology
- The complete product range for water applications
- Data sheets for ball valves
- Installation instructions for actuators and/or ball valves
- General notes for project planning