

- Actuating force 1500 N
- Nominal voltage AC/DC 24 V
- Control Open/close, 3-point
- Stroke 20 mm



Technical data

|                        |  |   |
|------------------------|--|---|
| <b>Electrical data</b> | Nominal voltage                        | AC/DC 24 V  |
|                        | Nominal voltage frequency              | 50/60 Hz  |
|                        | Nominal voltage range                  | AC 19.2...28.8 V / DC 21.6...28.8 V   |
|                        | Power consumption in operation         | 2.5 W   |
|                        | Power consumption in rest position     | 0.5 W   |
|                        | Power consumption for wire sizing      | 5 VA  |
|                        | Connection supply / control            | Terminals 4 mm <sup>2</sup> (cable Ø4...10 mm)  |
|                        | Parallel operation                     | Yes (note the performance data)   |
| <b>Functional data</b> | Actuating force motor                  | 1500 N  |
|                        | Manual override                        | with push-button, can be locked   |
|                        | Stroke                                 | 20 mm   |
|                        | Running time motor                     | 35 s / 20 mm  |
|                        | Sound power level, motor               | 60 dB(A)  |
|                        | Position indication                    | Mechanically, 5...20 mm stroke  |
| <b>Safety data</b>     | Protection class IEC/EN                | III Safety Extra-Low Voltage (SELV)   |
|                        | Protection class UL                    | UL Class 2 Supply   |
|                        | Degree of protection IEC/EN            | IP54  |
|                        | Degree of protection NEMA/UL           | NEMA 2 UL Enclosure Type 2  |
|                        | EMC                                    | CE according to 2014/30/EU  |
|                        | Certification IEC/EN                   | IEC/EN 60730-1 and IEC/EN 60730-2-14  |
|                        | Certification UL                       | cULus according to UL60730-1A, UL60730-2-14 and CAN/CSA E60730-1:02 The UL marking on the actuator depends on the production site, the device is UL-compliant in any case |
|                        | Mode of operation                      | Type 1  |
|                        | Rated impulse voltage supply / control | 0.8 kV  |
|                        | Control pollution degree               | 3   |
|                        | Ambient temperature                    | 0...50°C  |
|                        | Storage temperature                    | -40...80°C  |
|                        | Ambient humidity                       | Max. 95% r.H., non-condensing   |
|                        | Servicing                              | maintenance-free  |
| <b>Weight</b>          | Weight                                 | 1.8 kg  |

Safety notes



- This device has been designed for use in stationary heating, ventilation and air-conditioning systems and must not be used outside the specified field of application, especially in aircraft or in any other airborne means of transport.
- Outdoor application: only possible in case that no (sea) water, snow, ice, insulation or aggressive gases interfere directly with the device and that it is ensured that the ambient conditions remain within the thresholds according to the data sheet at any time.
- Only authorised specialists may carry out installation. All applicable legal or institutional installation regulations must be complied during installation.
- The switch for changing the direction of motion and so the closing point may be adjusted only by authorised specialists. The direction of motion is critical, particularly in connection with frost protection circuits.
- The device may only be opened at the manufacturer's site. It does not contain any parts that can be replaced or repaired by the user.
- The device contains electrical and electronic components and must not be disposed of as household refuse. All locally valid regulations and requirements must be observed.

**Product features**

|                                       |  |
|---------------------------------------|--|
| <b>Mounting on third-party valves</b> | The retrofit actuators for installation on a wide range of valves from various manufacturers are comprised of an actuator, bracket, universal valve neck adapter and universal valve stem adapter. Adapt the valve neck and valve stem to begin with, then attach the retrofit bracket to the valve neck adapter. Now fit the retrofit actuator into the bracket and connect it to the valve. Whilst taking the position of the valve closing point into account, secure the actuator to the bracket and then conduct the commissioning process. The valve neck adapter/actuator can be rotated through 360° on the valve neck, provided it is permitted by the size of the installed valve. |
| <b>Mounting on Belimo valves</b>      | Use standard actuators from Belimo for mounting on Belimo globe valves. The installation of retrofit actuators on Belimo globe valves is technically possible.   |
| <b>Manual override</b>                | Manual override with push-button possible (the gear is disengaged for as long as the button is pressed or remains locked).<br><br>The stroke can be adjusted by using a hexagon socket screw key (4 mm), which is inserted into the top of the actuator. The stroke shaft extends when the key is rotated clockwise.   |
| <b>High functional reliability</b>    | The actuator is overload protected, requires no limit switches and automatically stops when the end stop is reached.   |
| <b>Position indication</b>            | The stroke is indicated mechanically on the bracket with tabs. The stroke range adjusts itself automatically during operation.   |
| <b>Home position</b>                  | Factory setting: Actuator spindle is retracted.  |
| <b>Setting direction of stroke</b>    | When actuated, the stroke direction switch changes the running direction in normal operation.  |
| <b>Restriction 3-point controller</b> | It must be ensured that the pulsating 3-point controller stops when the end position is reached. If this is not possible on the system side, the multifunctional 24 V version of the actuator (..V24A-MP-..) must be used.   |

**Accessories**

|                               |                                      |             |
|-------------------------------|--------------------------------------|-------------|
| <b>Electrical accessories</b> | <b>Description</b>                   | <b>Type</b> |
|                               | Auxiliary switch 2 x SPDT add-on     | S2A-H       |
| <b>Mechanical accessories</b> | <b>Description</b>                   | <b>Type</b> |
|                               | Spacer ring for LDM, stroke 20 mm    | ZNV-203     |
|                               | Spacer ring for Sauter, stroke 20 mm | ZNV-204     |
|                               | Adapter kit Danfoss                  | ZNV-205     |

**Electrical installation**



- Supply from isolating transformer.**
- Parallel connection of other actuators possible. Observe the performance data.**
- Direction of stroke switch factory setting: Actuator spindle retracted (▲).**

### Wiring diagrams

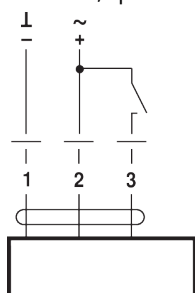
AC/DC 24 V, open/close

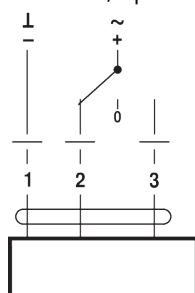

AC/DC 24 V, 3-point



### Operating controls and indicators

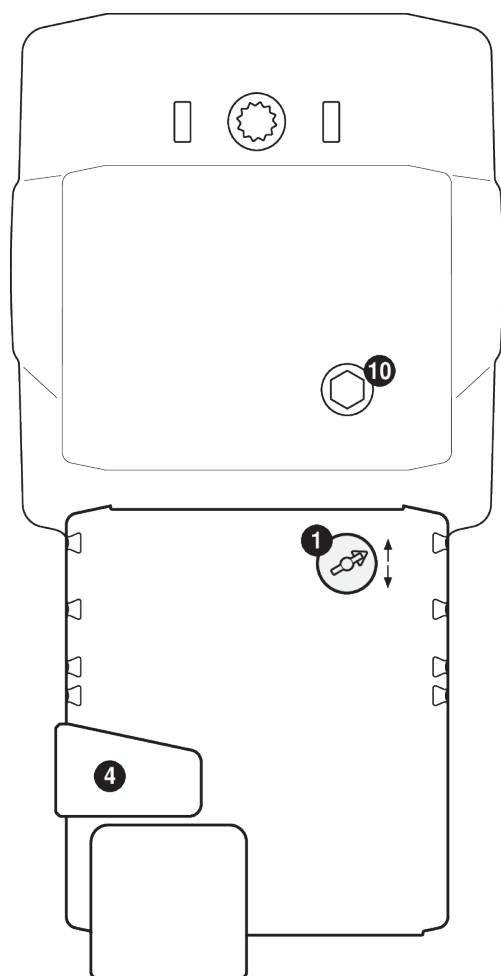

#### 1 Direction of stroke switch

Switch over: Direction of stroke changes

#### 4 Gear disengagement button

Press button: Gear disengages, motor stops, manual override possible

Release button: Gear engages, standard mode

#### 10 Manual override

Clockwise: Actuator spindle extends

Counterclockwise: Actuator spindle retracts

### Dimensions

#### Dimensional drawings

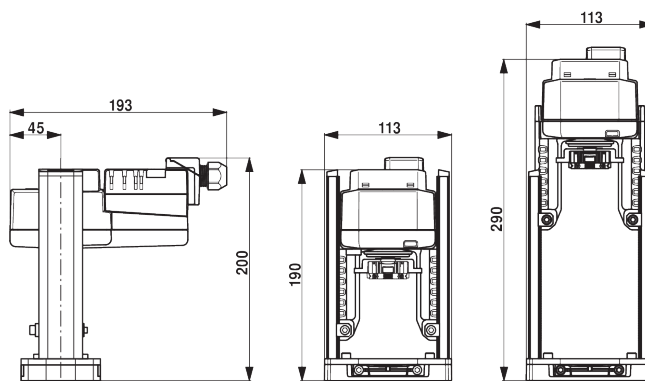

## Further documentation

- Installation instructions for actuators