



# U-GAGE® T30UX Series with Analog Output

Ultrasonic Sensor with TEACH-Mode Configuration

## Features



- 1, 2 and 3 m versions with short dead zones (10% of max. range)
- Built-in temperature compensation
- Fast, easy-to-use TEACH-mode configuration; no potentiometer adjustments
- Configure with either a positive or negative analog output slope
- Remote TEACH for security and convenience
- Wide operating temperature range of  $-40^{\circ}$  to  $+70^{\circ}$  C ( $-40^{\circ}$  to  $+158^{\circ}$  F)
- Choose either 0 to 10V dc or 4 to 20 mA output model
- Compact, self-contained, right-angle sensor package with fully encapsulated electronics



## Models

Models	Range and Frequency	Cable*	Supply Voltage	Analog Output	Response Time
T30UXUA	100 mm to 1 m (3.9" to 39")	Standard 2 m (6.5') cable	10 to 30V dc	0 to 10V dc	45 ms or 105 ms selectable
T30UXIA	224 kHz			4 to 20 mA	45 ms or 105 ms selectable
T30UXUB	200 mm to 2 m (7.8" to 78")			0 to 10V dc	92 ms or 222 ms selectable
T30UXIB	174 kHz			4 to 20 mA	92 ms or 222 ms selectable
T30UXUC	300 mm to 3 m (11.8" to 118")			0 to 10V dc	135 ms or 318 ms selectable
T30UXIC	114 kHz			4 to 20 mA	135 ms or 318 ms selectable

\* Only standard 2 m (6.5') cable models are listed. For 4-Pin Euro-Style integral QD, add suffix "Q8" to the model number (e.g., T30UXUAQ8). For 150 mm (6") PUR pigtail cable with 4-Pin threaded Euro-Style QD, add suffix "QPMA" to the model number (e.g., T30UXUAQPMA). For 9 m (30') cable, add suffix "W/30" to the model number (e.g., T30UXUA W/30).

A model with a QD connector requires a mating cable; see page 9.

### WARNING . . . Not To Be Used for Personnel Protection

Never use these products as sensing devices for personnel protection. Doing so could lead to serious injury or death.

These sensors do NOT include the self-checking redundant circuitry necessary to allow their use in personnel safety applications. A sensor failure or malfunction can cause either an energized or de-energized sensor output condition. Consult your current Banner Safety Products catalog for safety products which meet OSHA, ANSI and IEC standards for personnel protection.



141958

# U-GAGE® T30UX Series with Analog Output

## Overview

The U-GAGE® T30UX is an easy-to-use ultrasonic sensor with extended range and built-in temperature compensation. Simple push button configuration provides flexibility for a variety of applications.

Easy-to-see indicator LEDs communicate the status of the sensor (see Figure 1). The Green “Power” LED ON indicates that the sensor is in Run Mode (the sensor’s normal operating condition). The Red “Signal” LED indicates the target signal strength. The Amber “Output” LED indicates that the output is enabled and the sensor is receiving a signal within the window limits. The Amber “Mode LED” indicates the currently selected mode (fast or slow).

## Principles of Operation

Ultrasonic sensors emit one or multiple pulses of ultrasonic energy, which travel through the air at the speed of sound. A portion of this energy reflects off the target and travels back to the sensor. The sensor measures the total time required for the energy to reach the target and return to the sensor. The distance to the object is then calculated using the following formula:

$$D = \frac{ct}{2}$$

- D** = distance from the sensor to the target
- c** = speed of sound in air
- t** = transit time for the ultrasonic pulse

To improve accuracy, an ultrasonic sensor averages the results of several pulses before outputting a new value.

### Temperature Effects

The speed of sound is dependent upon the composition and temperature of the gas in which it is traveling. For most ultrasonic applications, the composition of the gas is fixed, while the temperature may fluctuate.

In air, the speed of sound varies with temperature according to the following approximation:

SI units:

$$C_{m/s} = 20 \sqrt{273 + T_c} \quad C_{m/s} = \text{speed of sound in meters per second}$$

$T_c$  = temperature in °C

Or, in US customary units:

$$C_{ft/s} = 49 \sqrt{460 + T_f} \quad C_{ft/s} = \text{speed of sound in feet per second}$$

$T_f$  = temperature in °F

### Temperature Compensation

Changes in air temperature affect the speed of sound, which in turn affects the total time for the echo measured by the sensor. An increase in air temperature shifts both sensing window limits closer to the sensor. Conversely, a decrease in air temperature shifts both limits farther away from the sensor. This shift is approximately 3.5% of the limit distance for a 20° C change in temperature.

The T30UX series ultrasonic sensors are temperature compensated. This reduces the error due to temperature by about 90%. The sensor will maintain its window limits to within 2.2% over the -40° to +70° C operating range of the sensor.

### NOTES:

- Exposure to direct sunlight can affect the sensor’s ability to accurately compensate for changes in temperature.
- If the sensor is measuring across a temperature gradient, the compensation will be less effective.



Figure 1. Features

# U-GAGE® T30UX Series with Analog Output

## Sensor Configuration

Two TEACH methods may be used to configure the sensor:

- Teach individual minimum and maximum limits, or
- Use Auto-Window feature to center a sensing window around the taught position.

The sensor may be configured either via its push button, or via a remote switch. Remote configuration also may be used to disable the push button, preventing unauthorized personnel from adjusting the configuration settings. To access this feature, connect the white wire of the sensor to 0V dc, with a remote configuration switch between the sensor and the voltage.





Configuration is accomplished by following the sequence of input pulses. The duration of each pulse (corresponding to a push button “click”), and the period between multiple pulses, are defined as “T”:

$$0.04 \text{ seconds} < T < 0.8 \text{ seconds}$$

Remote line configuration requires a > 1 second pause between pulse sequences.

## Mode Setup – Response Speed

Analog sensor models can be set up for either “Fast” or “Slow” response time

	Push Button 0.04 sec. < “click” < 0.8 sec.		Remote Line 0.04 sec. < T < 0.8 sec.	
	Procedure	Result	Procedure	Result
<b>Response Speed Configuration</b>	<ul style="list-style-type: none"> <li>• Push and hold <b>MODE</b> push button for &gt; 2 seconds</li> </ul> 	<b>Power LED:</b> OFF <b>Mode LED:</b> Flashing Amber shows previously selected mode	<ul style="list-style-type: none"> <li>• Double-pulse the remote line</li> </ul> 	<b>Power LED:</b> OFF <b>Mode LED:</b> Flashing Amber shows previously selected mode
<b>Select Speed</b>	<ul style="list-style-type: none"> <li>• “Click” the <b>MODE</b> push button to cycle to correct selection: Fast or Slow</li> </ul> 	<b>Power LED:</b> OFF <b>Mode LED:</b> Amber flashes to indicate currently selected mode (120 second time out*)	<ul style="list-style-type: none"> <li>• Single-pulse for Slow</li> <li>• Double-pulse for Fast</li> </ul>	<b>Power LED:</b> ON Green <b>Mode LED:</b> On Amber shows selected mode (Sensor returns to RUN mode)
<b>Save and Activate Mode</b>	<ul style="list-style-type: none"> <li>• Push and hold <b>MODE</b> push button for &gt; 2 seconds</li> </ul> 	<b>Power LED:</b> ON Green <b>Mode LED:</b> ON Amber for selected mode	<ul style="list-style-type: none"> <li>• No action required; sensor will return to Run Mode</li> </ul>	None

\* The sensor will revert to previously saved response speed and return to RUN mode if TEACH is inactive for 120 seconds after the initial 2 second hold on push button

# U-GAGE® T30UX Series with Analog Output

## Analog Output

The U-GAGE T30UX series sensor may be configured for either a positive or a negative output slope, based on which condition is taught first (see figure 2). If the near limit is taught first, the slope will be positive; if the far limit is taught first, the slope will be negative. Banner's scalable analog output automatically distributes the output signal over the width of the programmed sensing window.

The U-GAGE T30UX also features a 2-second hold upon loss of the received signal, which is useful for harsh and unstable applications. In the event of signal loss for longer than 2 seconds, the analog output goes to 3.6 mA or 0V dc, which may be used to trigger an alarm.

## Teaching Minimum and Maximum Limits

### General Notes on Teaching

- The sensor will return to RUN mode if the first TEACH condition is not registered within 120 seconds after the initial 2 second hold on Analog push button.
- To exit TEACH mode without saving any changes, press and hold the Analog push button or remote line > 2 seconds (before teaching the second limit). The sensor will revert to the last saved limits.
- After the first limit is taught, the sensor will remain in TEACH mode until the TEACH sequence is finished or exited by a 2 second hold on the Analog push button or remote line.

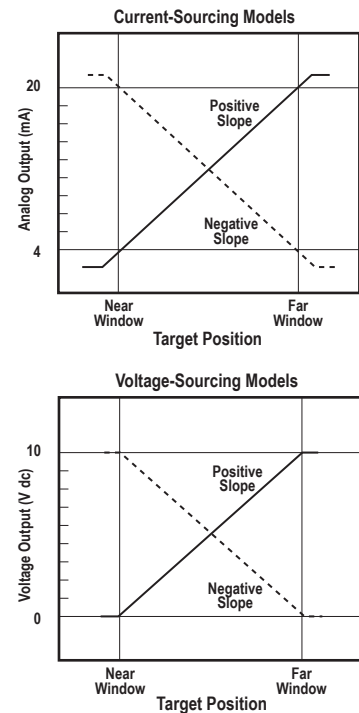







Figure 2. Positive and Negative Output Slopes

	Push Button 0.04 sec. < "click" < 0.8 sec.		Remote Line 0.04 sec. < T < 0.8 sec.	
	Procedure	Result	Procedure	Result
<b>TEACH Mode</b>	<ul style="list-style-type: none"> <li>• Push and hold Analog push button for &gt; 2 seconds</li> </ul> 	<b>Power LED: OFF</b> <b>Output LED: ON</b>	<ul style="list-style-type: none"> <li>• No action required; sensor is ready for 1st limit teach</li> </ul>	None
<b>Teach First Limit</b>	<ul style="list-style-type: none"> <li>• Position the target for the first limit (120 second time out)</li> </ul>	<b>Signal LED: Must be ON Red or Flashing Red*</b>	<ul style="list-style-type: none"> <li>• Position the target for the first limit</li> </ul>	<b>Signal LED: Must be ON Red or Flashing Red*</b>
	<ul style="list-style-type: none"> <li>• "Click" the Analog push button</li> </ul> 	<b>Teach Accepted</b> <b>Power LED: OFF</b> <b>Output LED: Flashing</b> <b>Teach Not Accepted</b> <b>Output LED: ON</b>	<ul style="list-style-type: none"> <li>• Single-pulse the remote line</li> </ul> 	<b>Teach Accepted</b> <b>Power LED: OFF</b> <b>Output LED: Flashing</b> <b>Teach Not Accepted</b> <b>Power LED: ON</b>
<b>Teach Second Limit</b>	<ul style="list-style-type: none"> <li>• Position the target for the second limit (no time out)</li> </ul>	<b>Signal LED: Must be ON Red or Flashing Red</b>	<ul style="list-style-type: none"> <li>• Position the target for the second limit (no time out)</li> </ul>	<b>Signal LED: Must be ON Red or Flashing Red</b>
	<ul style="list-style-type: none"> <li>• "Click" the Analog push button</li> </ul> 	<b>Teach Accepted</b> <b>Output LED: ON</b> <b>Power LED: ON</b> <b>Teach Not Accepted</b> <b>Output LED: Flashing</b> <b>Power LED: OFF</b>	<ul style="list-style-type: none"> <li>• Single-pulse the remote line</li> </ul> 	<b>Teach Accepted</b> <b>Output LED: Turns ON</b> <b>Power LED: ON</b> <b>Teach Not Accepted</b> <b>Output LED: Flashing</b> <b>Power LED: OFF</b>

\* Sensor will not Teach or indicate "Teach Not Accepted" when there is no signal present (Signal LED Red or Flashing Red)





# U-GAGE® T30UX Series with Analog Output

## Teaching Limits Using the Auto-Window Feature

Teaching the same limit twice automatically centers a 100 mm window on the taught position.

### General Notes on Teaching

- The sensor will return to RUN mode if the first TEACH condition is not registered within 120 seconds after the initial 2 second hold on Analog push button.
- To exit TEACH mode without saving any changes, press and hold the Analog push button or remote line > 2 seconds (before teaching the second limit). The sensor will revert to the last saved limits.
- After the first limit is taught, the sensor will remain in TEACH mode until the TEACH sequence is finished or exited by a 2 second hold on the Analog push button or remote line.

	Push Button 0.04 sec. < "click" < 0.8 sec.		Remote Line 0.04 sec. < T < 0.8 sec.	
	Procedure	Result	Procedure	Result
<b>TEACH Mode</b>	<ul style="list-style-type: none"> <li>• Push and hold <b>Analog</b> push button for &gt; 2 seconds</li> </ul> 	<b>Power LED: OFF</b> <b>Output LED: ON</b>	<ul style="list-style-type: none"> <li>• No action required; sensor is ready for 1st limit teach</li> </ul>	None
<b>Teach First Limit</b>	<ul style="list-style-type: none"> <li>• Position the target for the center of window (120 second time out)</li> </ul>	<b>Signal LED: Must be ON Red or Flashing Red*</b>	<ul style="list-style-type: none"> <li>• Position the target for the center of window</li> </ul>	<b>Signal LED: Must be ON Red or Flashing Red*</b>
	<ul style="list-style-type: none"> <li>• "Click" the <b>Analog</b> push button</li> </ul> 	<b>Teach Accepted</b> <b>Power LED: OFF</b> <b>Output LED: Flashing</b> <b>Teach Not Accepted</b> <b>Output LED: ON</b>	<ul style="list-style-type: none"> <li>• Single-pulse the remote line</li> </ul> 	<b>Teach Accepted</b> <b>Power LED: OFF</b> <b>Output LED: Flashing</b> <b>Teach Not Accepted</b> <b>Power LED: ON</b>
<b>Re-Teach Limit</b>	<ul style="list-style-type: none"> <li>• Without moving the target, "click" the <b>Analog</b> push button again</li> </ul> 	<b>Teach Accepted</b> <b>Output LED: ON</b> <b>Power LED: ON</b> <b>Teach Not Accepted</b> <b>Output LED: Flashing</b> <b>Power LED: OFF</b>	<ul style="list-style-type: none"> <li>• Without moving the target, single-pulse the remote line again</li> </ul> 	<b>Teach Accepted</b> <b>Output LED: ON</b> <b>Power LED: ON</b> <b>Teach Not Accepted</b> <b>Output LED: Flashing</b> <b>Power LED: OFF</b>

\* Sensor will not Teach or indicate "Teach Not Accepted" when there is no signal present (Signal LED Red or Flashing Red)

# U-GAGE® T30UX Series with Analog Output

## Remote Line TEACH

### General Notes

- **Run Mode** is the sensor's normal operating condition
- The duration of each **Pulse** is defined as "T":  $0.04 < T < 0.8 \text{ s}$  
- A **Hold** will exit TEACH MODE and return to Run Mode with previously saved changes. The duration of a **Hold** is:  $T > 2 \text{ s}$
- A **Timeout** will occur if a condition is not registered within 120 seconds, causing the sensor to return to Run Mode (during sensor configuration only)
- Sensor configuration user feedback shown on Green LED. See flow chart below.
- The Red Signal LED will be ON whenever the target is in view

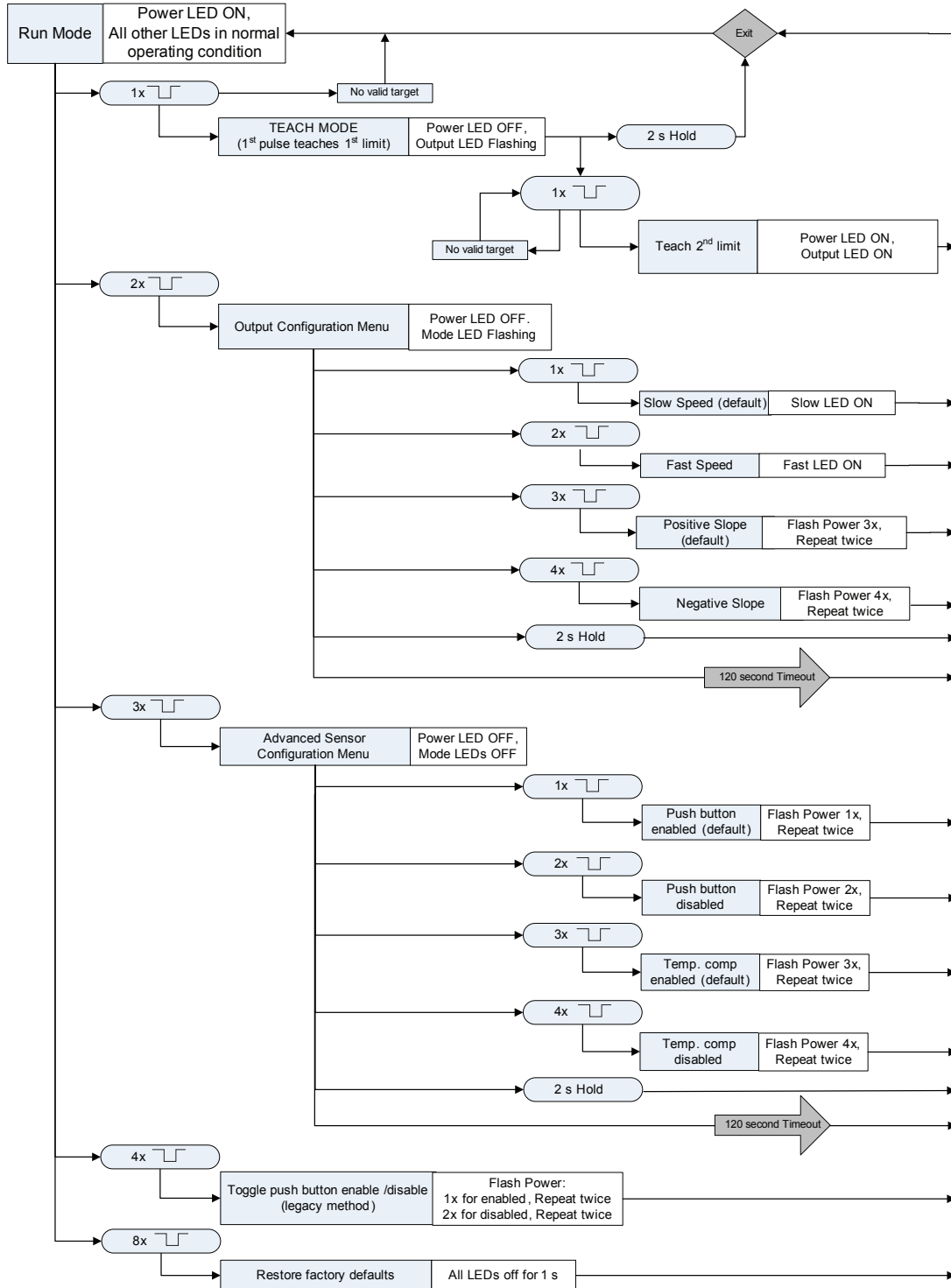

# U-GAGE® T30UX Series with Analog Output

## Specifications

<b>Sensing Range</b>	<p>"A" suffix models: 100 mm to 1 m (3.9" to 39")</p> <p>"B" suffix models: 200 mm to 2 m (7.8" to 78")</p> <p>"C" suffix models: 300 mm to 3 m (11.8" to 118")</p>
<b>Ultrasonic Frequency</b>	<p>"A" suffix models: 224 kHz</p> <p>"B" suffix models: 174 kHz</p> <p>"C" suffix models: 114 kHz</p>
<b>Supply Voltage</b>	10 to 30V dc (10% max. ripple) at 40 mA, exclusive of load
<b>Supply Protection Circuitry</b>	Protected against reverse polarity and transient voltages
<b>Output Configuration</b>	<b>Analog Output:</b> 0 to 10V dc or 4 to 20 mA, depending on model
<b>Output Rating</b>	<p><b>Analog Voltage Output:</b> 2.5 k<math>\Omega</math> min. load resistance Minimum supply for a full 10V output is 12V dc (for supply voltages between 10 and 12, V out max. is at least V supply -2)</p> <p><b>Analog Current Output:</b> 1 k<math>\Omega</math> max. @ 24V input; max. load resistance = (Vcc-4)/0.02<math>\Omega</math></p> <p><b>For current output (4-20 mA) models,</b> ideal results are achieved when the total load resistance <math>R = [(V_{in} - 4)/0.020]\Omega</math>. Example, at <math>V_{in} = 24V</math> dc, <math>R \approx 1</math> k<math>\Omega</math> (1 watt)</p>
<b>Output Protection Circuitry</b>	Protected against short circuit conditions
<b>Output Response Time</b>	<p>"A" suffix models: 45 ms (fast); 105 ms (slow)</p> <p>"B" suffix models: 92 ms (fast); 222 ms (slow)</p> <p>"C" suffix models: 135 ms (fast); 318 ms (slow)</p>
<b>Delay at Power-up</b>	500 ms
<b>Temperature Effect</b>	0.02% of distance/ $^{\circ}C$
<b>Linearity</b>	0.25% of distance
<b>Resolution</b>	<p>"A" suffix models: 0.1% of distance (0.5 mm min.)</p> <p>"B" suffix models: 0.1% of distance (1.0 mm min.)</p> <p>"C" suffix models: 0.1% of distance (1.5 mm min.)</p>
<b>Minimum Window Size</b>	10 mm (0.4")
<b>Adjustments</b>	<p><b>Sensing window limits:</b> TEACH-Mode configuration of near and far window limits may be set using the push button or remotely via TEACH input (see pages 4-6).</p> <p><b>Response speed selection:</b> Fast or Slow (see pages 3 or 6)</p> <p><b>Advanced configuration options:</b> Analog output slope, push button enabled/disabled, temperature compensation enabled/disabled (see page 6)</p>
<b>Indicators</b>	See page 2
<b>Loss of Signal Indication</b>	<p><b>0 to 10V dc models:</b> Analog output goes to 0V</p> <p><b>4 to 20 mA models:</b> Analog output goes to 3.6 mA</p>
<b>Construction</b>	<p><b>Housing:</b> PBT polyester    <b>Push buttons:</b> polyester</p> <p><b>Transducer:</b> epoxy /ceramic composite</p>
<b>Environmental rating</b>	Leakproof design, rated IEC IP67 (NEMA 6)
<b>Connections</b>	2 m (6.5') or 9 m (30') shielded 4-conductor (with drain) PVC cable, 150 mm (6") PUR Euro-style pigtail (QPMA), or 4-pin integral Euro-style connector (Q8)
<b>Operating Conditions</b>	<p><b>Temperature:</b> -40 to 70<math>^{\circ}C</math> (-40 to +158<math>^{\circ}F</math>)</p> <p><b>Max. Relative Humidity:</b> 95% at 50<math>^{\circ}C</math> non-condensing</p>
<b>Vibration and Mechanical Shock</b>	All models meet Mil. Std. 202F requirements method 201A (vibration: 10 to 60 Hz max., double amplitude 0.06", max acceleration 10G). Also meets IEC 947-5-2; 30G 11 ms duration, half sine wave
<b>Application Note</b>	The temperature warmup drift upon power-up is less than 1% of the sensing distance.
<b>Certifications</b>	CE Pending

# U-GAGE® T30UX Series with Analog Output

## Performance Curves

### With Plate Target (Typical)

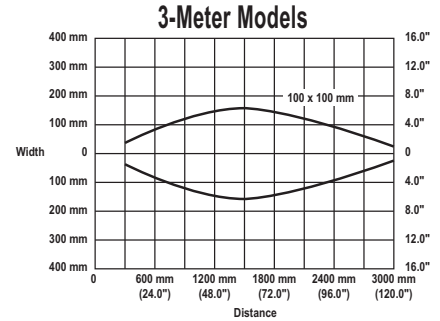
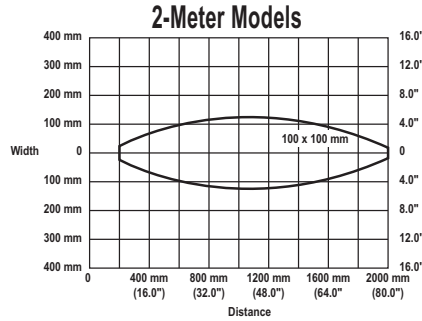
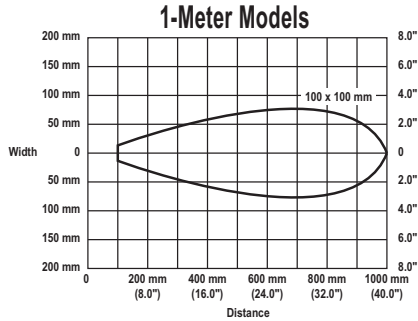

### With Rod Target (Typical)

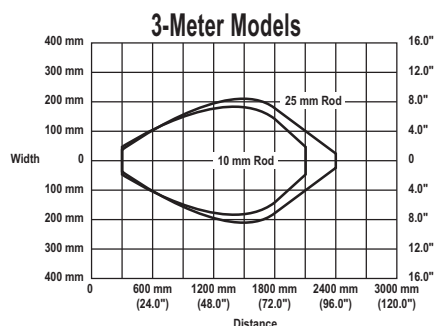
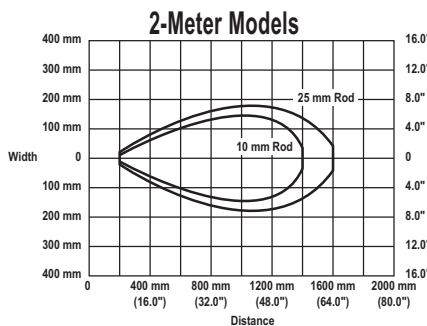
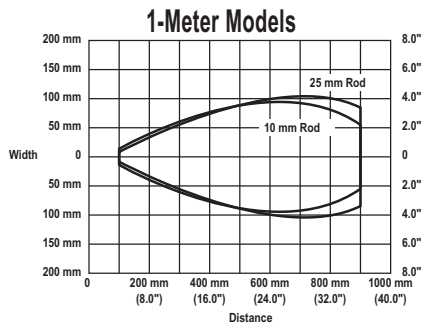

## Maximum Target Rotation Angle

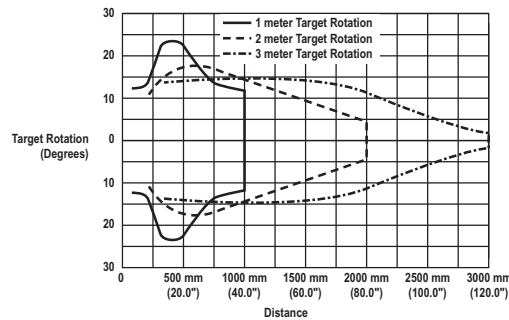

## Hookups

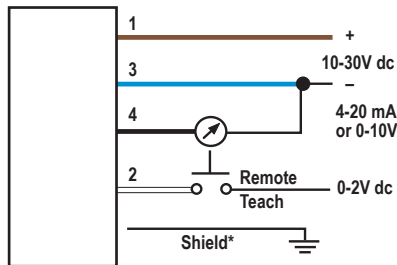

Wiring Key:  
 1 = Brown  
 2 = White  
 3 = Blue  
 4 = Black

Cable and QD hookups are functionally identical.

It is recommended that the shield wire be connected to earth ground. Shielded cordsets are recommended for all QD models.



# U-GAGE® T30UX Series with Analog Output

## Dimensions

All measurements given in mm

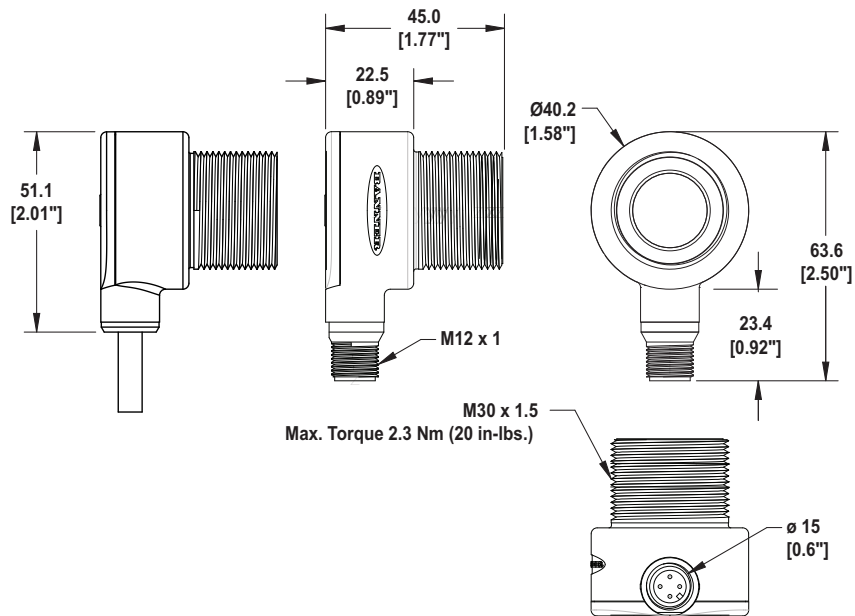

Locknut (included with all models)

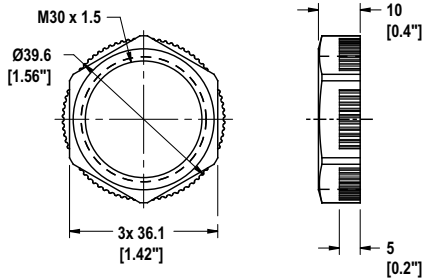

Washer (included with all models)

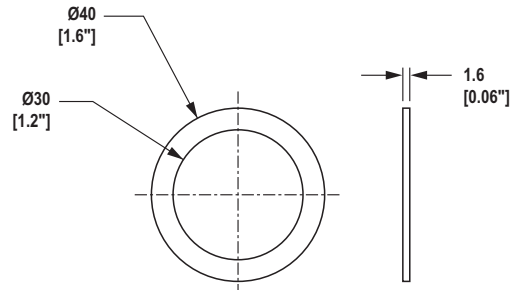

## Accessories

### Quick-Disconnect Cables

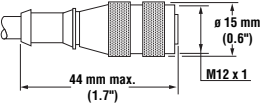
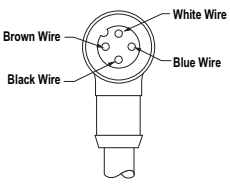
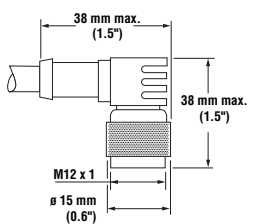
Style	Model	Length	Dimensions	Pinout
4-pin Euro-style Straight with shield	MQDEC2-406 MQDEC2-415 MQDEC2-430	2 m (6.5') 5 m (15') 9 m (30')		
4-pin Euro-style Right-angle with shield	MQDEC2-406RA MQDEC2-415RA MQDEC2-430RA	2 m (6.5') 5 m (15') 9 m (30')		

# U-GAGE® T30UX Series with Analog Output

## Mounting Brackets

<p><b>SMB30A</b></p>	<ul style="list-style-type: none"> <li>• Angled-mount bracket</li> <li>• Stainless steel</li> </ul>	<p><b>SMB1815SF</b></p>	<ul style="list-style-type: none"> <li>• Swivel with set screws for mounting sensors by the cable hub</li> <li>• Black reinforced thermoplastic polyester</li> <li>• Stainless steel swivel locking hardware and hex wrench included</li> </ul>
<p>* Use 5 mm (#10) screws to mount bracket. Drill screw holes 40.0 mm (1.58\") apart.</p>			
<p><b>SMB30FA</b></p>	<p><b>SMB30SC</b></p>	<p><b>30 mm Bracket</b></p> <p><b>Clamp</b></p>	

# U-GAGE® T30UX Series with Analog Output

---

# U-GAGE® T30UX Series with Analog Output

---



**WARRANTY:** Banner Engineering Corp. warrants its products to be free from defects for one year. Banner Engineering Corp. will repair or replace, free of charge, any product of its manufacture found to be defective at the time it is returned to the factory during the warranty period. This warranty does not cover damage or liability for the improper application of Banner products. This warranty is in lieu of any other warranty either expressed or implied.

P/N 141958 rev. B

Banner Engineering Corp., 9714 Tenth Ave. No., Minneapolis, MN USA 55441 • Phone: 763.544.3164 • [www.bannerengineering.com](http://www.bannerengineering.com) • Email: [sensors@bannerengineering.com](mailto:sensors@bannerengineering.com)