

## Bus Coupling Unit (BTM) UP117C12

5WG1 117-2CB12

June 2014/ Page 1

### Application Program

The Bus Coupling Unit (BTM) does not require an application program.



### Product and Applications Description

Bus Coupling Units (BTM) UP 117C12 provide the connection to the bus for DELTA switches and wall box mounted control devices with Bus Transceiver Interface (BTI).

The Bus Coupling Unit (BTM) UP 117C12 comes with a mounting frame for NEMA type wall boxes.

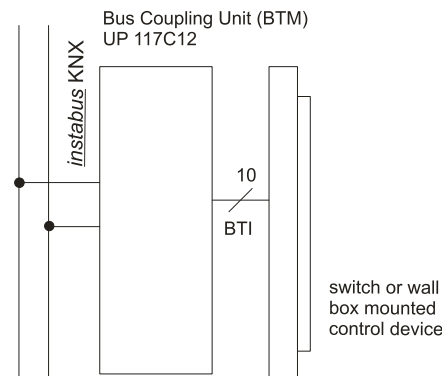

Example of Operation

### Technical Specifications

Power supply  
Input voltage

- Bus: DC 24V (DC 21...30V)

Output voltage and current via BTI

- DC 5V, 10mA
- DC 20V, 25mA

Operator elements

The device has no operation elements.

Display elements

The device has no display elements.

Connections

- Bus line : screwless bus connection block (red-black) 0.6...0.8 mm Ø single core
- 10-pin socket (BTI): for connection of DELTA switches and wall box mounted control devices with BTI plug

Physical specifications

- housing: plastic
- dimensions (L x W x D) :  
length : 111 mm (4.37 inch)  
width : 65 mm (2.56 inch)  
depth : 19 mm (0.75 inch)
- weight: approx. 64 g
- fire load: 1 MJ
- installation: mounted with mounting frame on NEMA type wall boxes

Electrical safety

- degree of pollution (according to IEC 60664-1): 2
- protection (according to EN 60529): IP 20
- overvoltage class (according to IEC 60664-1): III
- bus: safety extra low voltage SELV DC 24 V
- the device complies with EN 50428

Electromagnetic compatibility

complies with EN 50428 and EN 61000-6-2

Environmental specifications

- ambient temperature operating: + 23 ... + 113 °F
- ambient temperature non-op.: - 13 ... + 158 °F
- relative humidity (non-condensing): 5 % to 93 %

Reliability

- Failure rate: 80,3 fit at 40°C

Markings

EIB, KNX

### Listings and Certifications

CE mark  
complies with the EMC regulations (residential and functional buildings) and low voltage regulations

UL listed (E464611)

UL 916, Open Energy Management Equipment

**Bus Coupling Unit (BTM)  
UP117C12**

5WG1 117-2CB12

June 2014/ Page 2

**Location and Function of Interface Elements**

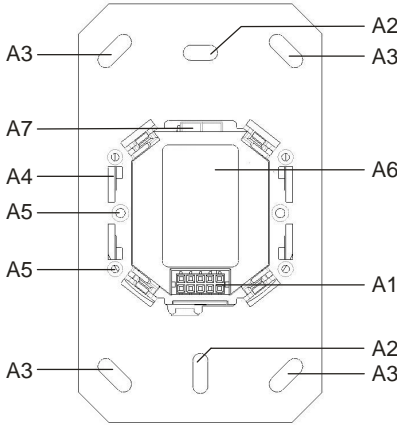

- A1 Bus Transceiver Interface (BTI) socket for connecting an application unit with BTI plug
- A2 Slots for attaching the Bus Coupling Unit (BTM) to wall boxes (2" x 4" wall box or plaster ring on 4" x 4" wall box)
- A3 Slots for attaching the Bus Coupling Unit (BTM) to wall boxes (4" x 4" wall box)
- A4 Slots for mounting application unit with guide and mounting clamps
- A5 Thread for mounting screws (for additional support, e.g. for securing the application unit against theft)
- A6 Type plate
- A7 Bus connection block for single core conductors with Ø 0.6 ... 0.8 mm

**Dimension Diagram**

Dimensions in mm

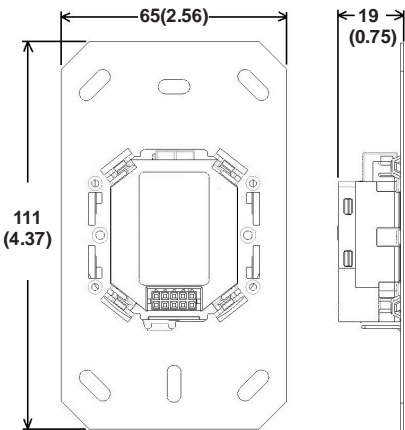

⚠ WARNING

**Class 2 power wiring only.**

**The device must be mounted and commissioned by an authorized electrician.**

**The prevailing safety rules must be heeded.**

**The device must not be opened.**  
**A device suspected faulty should be returned to the local Siemens sales office or distributor.**

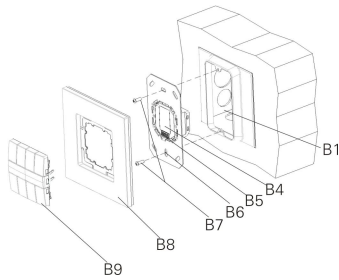

B1 Plaster ring on 4" x 4" wall box

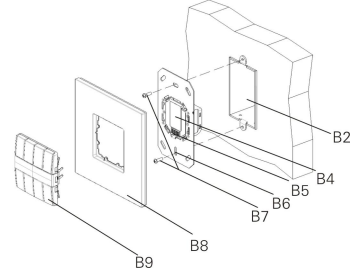

B2 2"x4" wall box (minimum internal width: 2 inch (50mm))

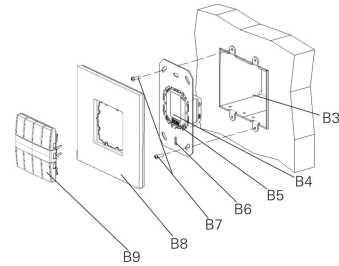

- B3 4"x4" wall box
- B4 Bus coupling unit UP 117C12
- B5 Bus Transceiver Interface (BTI)
- B6 Mounting screw holes
- B7 Mounting screws (delivered as part of the package)
- B8 Design frame
- B9 instabus wall switch, secure-in-place screws

**Mounting**

General description

The connection to the bus line is established via bus connection block 193 (screwless plug-in terminals for single core conductors). The application unit is slipped onto the bus coupling unit (BTM) via guide and mounting clamps and, depending on the device type, fastened with screws.

Note

The Bus Coupling Unit (BTM) UP 117C12 must be mounted with the Bus Transceiver Interface (BTI) situated at the bottom. Thus the application unit will be oriented properly when slid onto the BTI. Use bus devices with mounting screws only to achieve a permanently stable contact at the BTI.

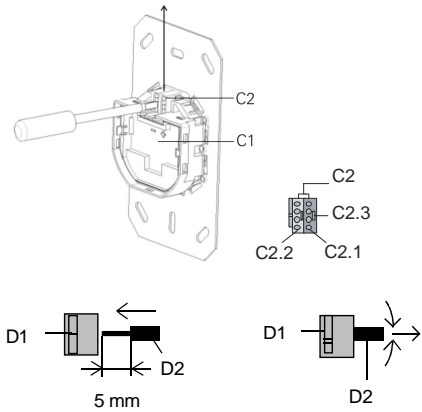

**Wiring**

**Slipping off/on bus connection blocks**

The bus connection block (C2) is situated on the back of the bus coupling unit (BTM) (C1). It consists of two components (C2.1 and C2.2) with four terminal contacts each. Take care not to damage the two test sockets (C2.3) by accidentally connecting them to the bus cable or with the screw driver (e.g. when attempting to unplug the bus connection block).

Slipping off bus connection blocks

- Carefully put the screw driver to the wire insertion slit of the bus connection block's grey component (C2.2) and
- pull the bus connection block (C2) from the bus coupling unit (BTM) (C1).

Note

Don't try to remove the bus connection block from the bottom side. There is a risk of shorting-out the device!

Slipping on bus connection blocks

- Slip the bus connection block (C2) onto the guide slot of the BTM (C1) and
- press the bus connection block (C2) down to the stop.

**Connecting and Disconnecting bus cables**

Connecting bus cables

- The bus connection block (D1) can be used with single core conductors Ø 0.6...0.8 mm.
- Remove approx. 5 mm of insulation from the conductor (D2) and plug it into the bus connection block (D1) (red = +, grey = -)

Disconnecting bus cables

- Unplug the bus connection block (D1) and remove the bus cable conductor (D2) while simultaneously wiggling it.