

VA7800 Series Self-Calibrating Pressure Controls for Steam, Air or (hot) Water

Product Bulletin

The VA7800 1000 N thrust valve actuators are available in Spring Return and Non-Spring Return models.

They are used to control valves in heating, ventilation and air conditioning applications.

All models have manual override as standard and provide stroke capabilities of 8 mm to 25 mm.

Proportional models are self-calibrating.

The actuator is intended for use with Johnson Controls VG7000 and VGS8 threaded valves as well as VG9000 and VG8000 flanged valves.

All valves should be fitted in accordance with the maximum close-off pressure ratings specified (see pertinent valve product bulletins).

Valve-actuators can be ordered as separate units or as a factory fitted valve / actuator combinations.



VA7800 Actuator mounted onto VG7000 Valve

- **Automatic stroke adjustment**
Easy, quick and precise commissioning and servicing.
- **Manual override as standard**
Allows manual positioning in absence of the power supply on all models for ease of commissioning and servicing.
- **IP54 enclosure protection**
Allows installation in a wide range of environments.
- **Unique swing-gate yoke**
Fast and secure attachment to valve.
- **Brushless motor**
Low energy consumption and long life.
- **Multiple input signals for ON/OFF, floating and proportional control**
One single actuator model can be used for various control types.
- **Selection of parameters via DIP switches**
Ease of commissioning, parameter settings and servicing in-situ.
- **Force controlled motor shut-off**
Reduces energy consumption, wear of the actuator and protects the valve from excessive forces.
- **Models with optional 2 aux. switches or 2 kOhm feedback potentiometer**
Provides potential free contacts for user availability or independent monitoring of the actuator's status.
- **Control-Signal loss - stem to pre-determined position**
Actuator pre-set position after a control signal failure (extended/retracted), is selectable in-situ.
- **Colored stroke position indicator**
Automatic adjustment of stroke indicators at the start of the first cycle and easy notice of valve status.
- **Status LED**
Visual operational status of the actuator and diagnostics.
- **Delivered with fitted 1.5 m cable**
Saves time and protects actuator during installation.
- **Spring Return function**
Models for spring extends stem and models for spring retracts stem.
- **Selectable actuation speed, 6s/mm or 3s/mm**
Allows optimum choice for application.

Operation

Non Spring Return models for Floating and On/Off control (VA7810-AGx-xx and VA7810-ADx-xx)

See figure 6

Connections	Actuator Stem
1-2	Extends
1-3	Retracts

Non Spring Return models with 0...2 kOhm potentiometer feedback output (VA7810-AGH-11)

The factory setting is 50 - 100 Ohm when the actuator stem is fully retracted.

To change the setting, the feedback signal is adjusted by means of the plastic knurled knob.

Spring Return actuators and Non-Spring Return actuators with auxiliary switches (VA78xx-xxC-xx)

VA7800 series actuator are available also as models with two built-in auxiliary switches that can be set by adjusting the cams seen in figure 1.

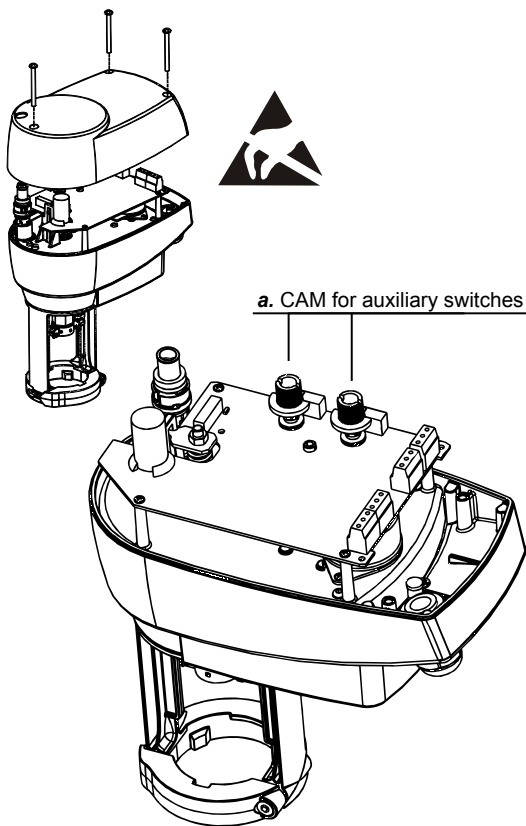

Figure 1: Auxiliary Switches

Non Spring Return and Spring Return models for Proportional control (VA78xx-GGA-xx)

All these actuators are suitable to multiple inputs which permit wiring for on/off or floating control.

When wired for proportional control the VA78x0-GGx provides a proportional stroke corresponding to the control signal.

Following control signals are defined as standard:

- 0...10 V DC
- 2...10 V DC
- 0...20 mA
- 4...20 mA

Action (DIP switch setting)	Input control signal	Actuator Stem	Actuator stem position at control-signal loss*
Direct (DA)	Increases Decreases	Extends Retracts	Selectable
Reverse (RA)	Increases Decreases	Retracts Extends	Selectable

Note: * "Control signal loss" position pre-set does not operate when 0...20 mA or custom input current range control is selected.

At each end of the span the actuator control signal has a buffer zone of 0.3 V (0.6 mA) in order to ensure definite valve close-off at maximum control signal range.

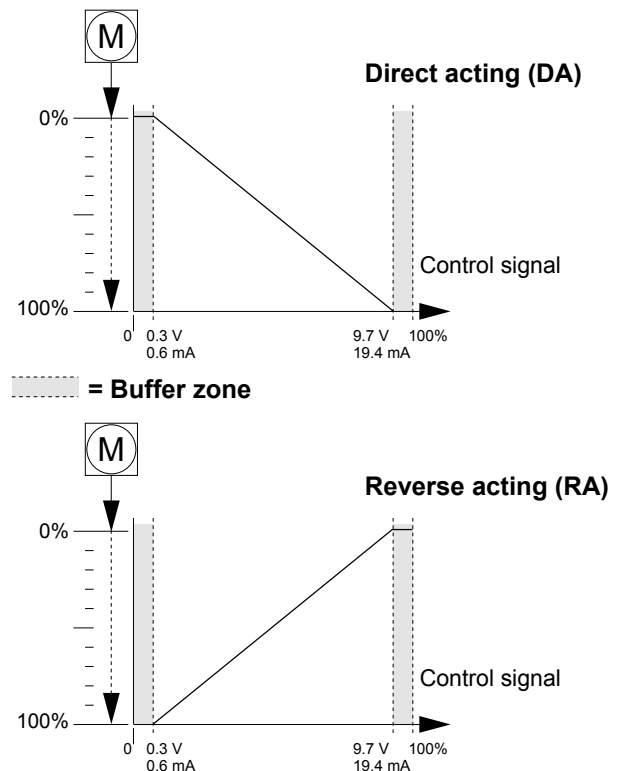

Figure 2: Control Signal

Control signal failure pre-set position

A loss of the control signal on proportional models will cause the actuator to automatically move the stem to a (via DIP-switch) pre-selected position (100% extended or 100% retracted).

Note: "Control signal loss" position pre-set does not operate when 0...20 mA or custom input current range control is selected.

Auto Calibration - Preset Signal Ranges

To change the Factory Default parameters the control input signal parameters can be selected by means of a DIP switch (see "DIP switch setting" on page 4). The standard control signals are selected by setting DIP switches 2, 3 and 4.

It is recommended that the desired actuator control signal and action be set before fitting to the valve. Power must be connected before the auto-calibration cycle can be started. The LED is illuminated green when the power is ON.

Procedure:

Condition: Actuator already mounted on valve.

To start the auto calibration cycle push and hold the button for at least 3 seconds (see figure 3). The LED flashes rapidly during the entire procedure. The actuator will make one full cycle to detect the stem extended and retracted limits. The end stroke indicators are automatically placed at the stroke limits. When the procedure ends, the actuator switches back to its operating mode and reaches the position corresponding to the input signal value. The LED shows steady green when the position is achieved.

If the control-signal changes, the actuator stem will move to the new position. During stem movement the LED flashes green.

Auto Calibration - Custom Signal Ranges

(Max range limits 0...10 V DC or 0...20 mA)

Procedure:

Condition: Actuator already mounted on valve.

To start the auto calibration cycle push and hold the button for at least 3 seconds (see figure 3). The LED flashes rapidly during the entire procedure. The actuator will make one full cycle to detect the stem extended and retracted limits. The end stroke indicators are automatically placed at the stroke limits. The actuator will make a full cycle to detect the stem extended and retracted limits and the end stroke indicators automatically pushed to the stroke limits. Enter the desired signal range while the actuator performs the auto calibration. Enter the desired parameters as follows:

- Set the Minimum input signal (start-point), which can be from 0...6 V DC (0...12 mA) and confirm by pressing the button (see figure 3).
- LED illuminates a steady green for 2 sec. indicating correct entry.
- If the LED illuminates a steady yellow for 2 sec., an incorrect setting is indicated and must be re-entered.
- Set the Maximum input signal, which can be from 3...10 V DC (6...20 mA) and confirm by pressing the button (span min. = 3 V DC or 6 mA).
- LED illuminates a steady green for 2 sec. indicating correct entry.
- If the LED illuminates a steady yellow for 2 sec., an incorrect setting is indicated and must be re-entered.

The maximum input signal is the control span plus the minimum input signal (start-point).

Note: It is only possible to make one correction after which the actuator will leave the calibration cycle.

After making the correct entry and confirming, the LED will illuminate green steadily for 2 sec. to indicate correct setting. If the LED illuminates a steady yellow for 2 sec. this indicates that the second entry is also erroneous and the calibration cycle will automatically abort. To restart the auto calibration cycle, push and hold the button for at least 3 seconds and repeat the procedure from the beginning.

When the procedure is finished the actuator returns to its operating mode, reaching the position corresponding to the input signal value, the LED will illuminate a steady green.

If the control-signal changes the actuator stem will move to the new position. During the stem movement the LED flashes green.

Position feedback

The position feedback signal is 0...10 V DC or 2...10 V DC and can be used to feed an external supervisory system. See table below for correspondence between control signal and feedback output.

Input Signal Range	Feedback Output Range
0-10 V	0-10 V
2-10 V	2-10 V
0-20 mA	0-10 V
4.20 mA	2-10 V
Custom Range	0-10 V

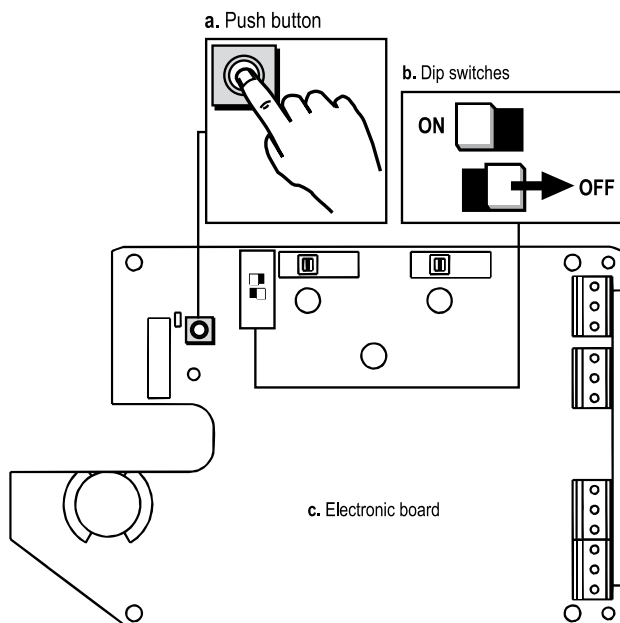
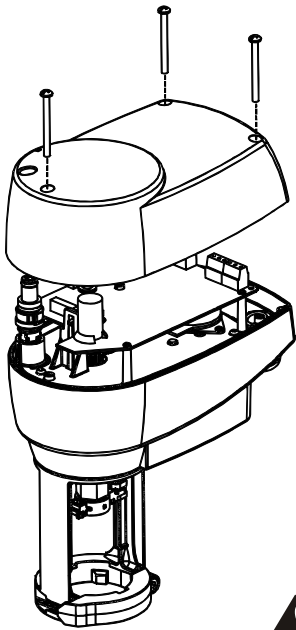

Figure 3: Auto Calibration

DIP switch settings (VA78xx-GGx-xx models only)

The DIP switches (see Fig. 3) permit easy in-situ setting of operational parameters without the need for any other configuration device.

DIP Switch Number	Description	State	
1	Control Type	ON	Floating/ON-OFF Control
		OFF	Proportional Control
2	Input signal	ON	Current Input Signal
		OFF	Voltage Input signal
3	Input Signal Range	ON	Custom Setting
		OFF	Pre-defined Setting
4		ON	2-10 V 4-20 mA
		OFF	0-10 v 0-20 mA
5	Action	ON	Reverse action
		OFF	Direct Action
6	Pre-set actuator position al signal loss*	ON	Actuator Stem Extends
		OFF	Actuator Stem Retracts
7	Stroke speed	ON	3 s/mm
		OFF	6 s/mm
8	Not used	Not used	

Note: * "Control signal loss" position pre-set does not operate when 0...20 mA or custom input current range control is selected.

LED indications

All versions for multiple input feature a multicoloured LED that permits visual operation status indication and failure analysis.

Led Color			
Status	Green	Yellow	Red
Off	Power off		
Blink	Motor running	Temporary fault, possible valve sticking**	High temperature*
Fast Blink	Calibrating	Input signal failure	
On	Power On, motor still	Custom calibration value out of range	Generic fault

Note: * Temporary: when the detected temperature decreases within the acceptable range, the LED switches back to green.
 ** The actuator leaves this mode only if the push button is pressed for at least 5 seconds, and the error previously detected has been resolved.

The actuator microprocessor carries out a failure diagnosis when a failure has been detected. The coloured LED indicates the actuator status. When the microprocessor detects that the stem has come to an unexpected stop, it initiates a retry cycle, this is repeated three times and, if unsuccessful, the actuator status switches to fault mode, the LED flashes yellow. If the problem is cleared, the actuator continues normal function.

Application: Parallel and sequenced operation of actuators

The number of actuators that can be linked to a single controller depends on the controller's active power in relation to the actuators power consumption.

Parallel operation of actuators for Floating or ON/OFF control

Even if all actuators have the same nominal running speed there can be deviations due tolerances and different load conditions. These deviations can accumulate with the number of performed cycles. By periodical switching of the actuators to end of travel parallel-operated actuators can run reasonably synchronous.

Actuators for proportional control

The controller output can operate several actuators for proportional control. The electrical wiring for parallel and sequenced operation is identical. The sequencing and action of the actuator are individually adjustable. Each actuator has its own adjustment for starting point and span. Using the minimum adjustable span enables a maximum of 3 sequenced devices; further sequencing can be accomplished by using additional controller outputs. Each actuator can be switched for direct or reverse action (see "DIP switch settings" on page 4).

Manual operation

All actuators can be manually repositioned by means of an Allen Wrench.

Non Spring Return Actuators

When the crank is inserted into the hexagonal opening and pushed down, the power to the motor is cut-off and manual operation is engaged. Turning the hand crank clockwise extends the stem and counter-clockwise retracts the stem. Pushing the hand crank down again disengages the manual operation and reconnects the power to the motor.

Spring Return Actuators

Manual operation is only possible when power is disconnected. At a power loss the actuator spring force moves stem to extended or retracted end position depending on model. To operate manually, put crank into hexagonal opening and turn clockwise or counter-clockwise depending on actuator model. When the desired stroke position is reached, push crank down and slightly rotate backwards to keep position. When power resumes, manual operation is de-activated.

After having used the manual override of Spring Return and Non Spring Return actuators it is recommended to operate a self-calibrating cycle in order to assure accurate alignment of the input signal with the actuator stem position.

Mounting instructions

When mounting the actuator on a valve, please follow the instructions below:

- It is recommended that the valve are mounted upright or at angles not greater than 90° in an easily accessible location.
- The valve must be installed so that the plug seats against the flow, as indicated by the arrows on the valve.
- Sufficient clearance must be allowed for actuator wiring and commissioning.
- Do not cover the actuator with insulating material.

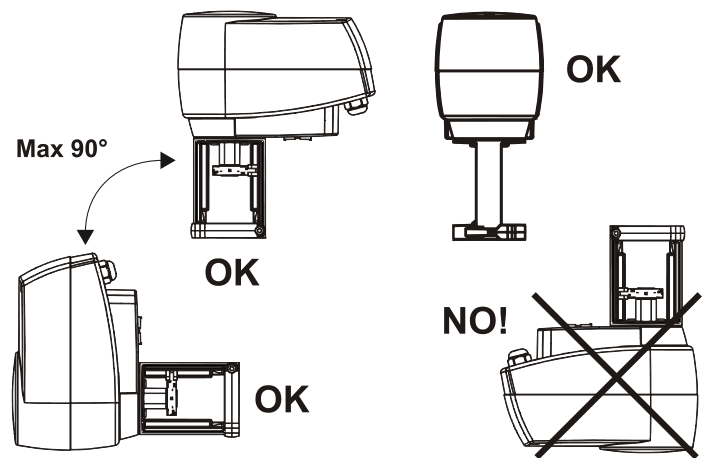

Figure 4: Mounting Positions

Wiring instructions

All wiring must be in accordance with local regulations and national electrical codes and should be carried out by authorised personnel only.

Make sure that the line power supply is in accordance with the power supply specified on the device.

See also the instructions in paragraph "Application".

Shock Hazard



- Disconnect the power supply before wiring connections are made to prevent personal injury.

Equipment Damage Hazard

- Make and check all wiring connections before applying power to the system. Short circuited or improperly connected wires may result in permanent damage to the unit.

Note: These actuators are intended to control equipment under normal operating conditions. Where failure or malfunction of the actuator could lead to an abnormal operating condition that could cause personal injury or damage to the equipment or other property, other devices (limit or safety controls) or systems (alarm or supervisory systems) intended to warn of or protect against failure or malfunction of the actuator must be incorporated into and maintained as part of the control system.

Wiring Diagrams

Actuators are delivered with a fitted 1.5 m long cable. The cable numbering corresponds to the actuator terminal numbering as seen in the wiring diagram.



IMPORTANT:

Take care that auxiliary switches S1 and S2 are NOT connected to different voltages (E.g. S1 230V and S2 24V NO!, S1 230V and S2 230V OK!)

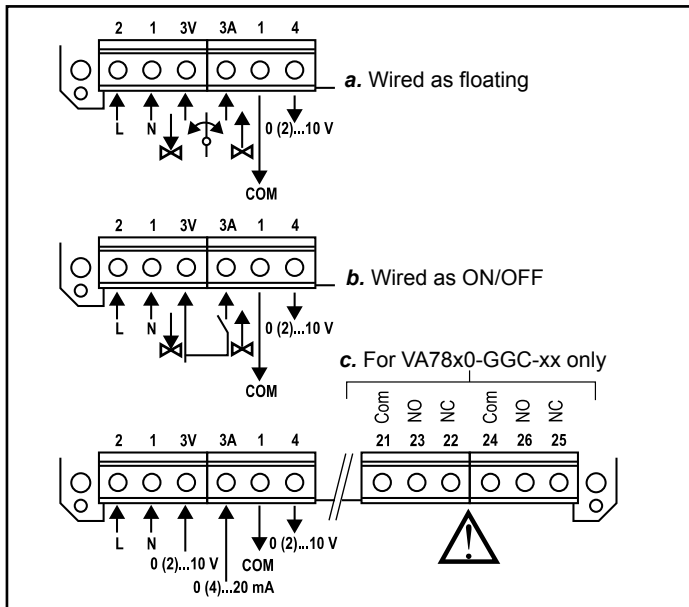

Figure 5: VA78x0-GGx-xx

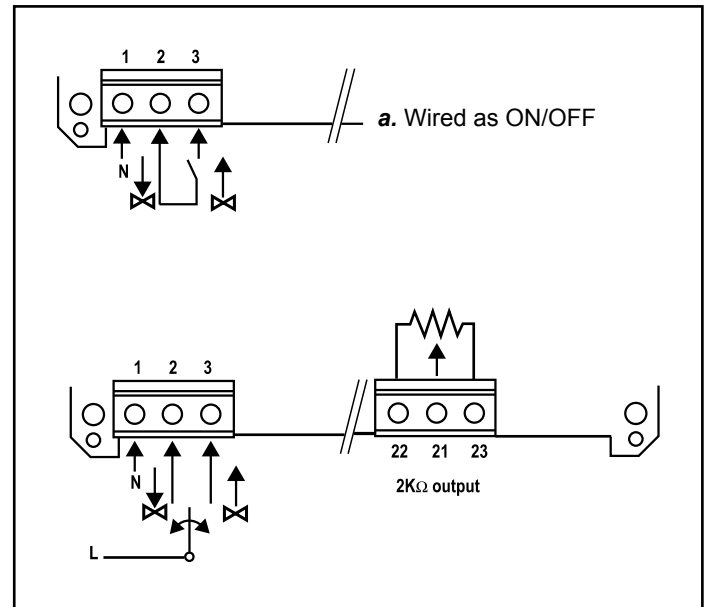

Figure 7: VA7810-AGH-xx

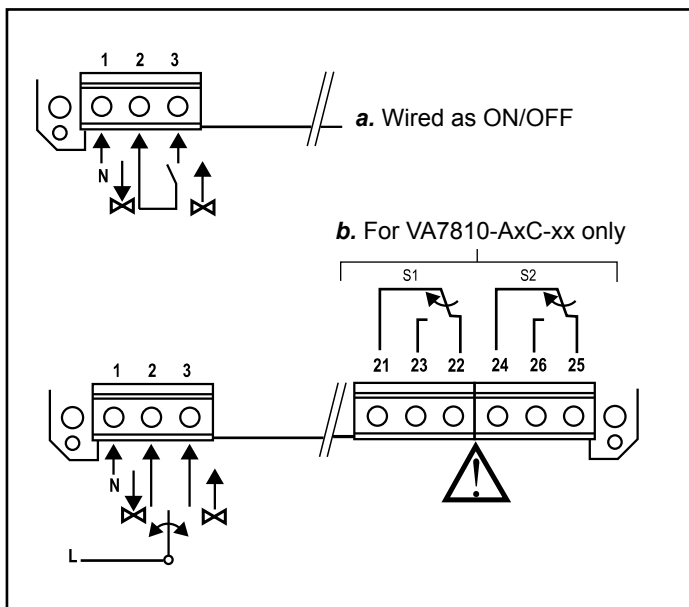
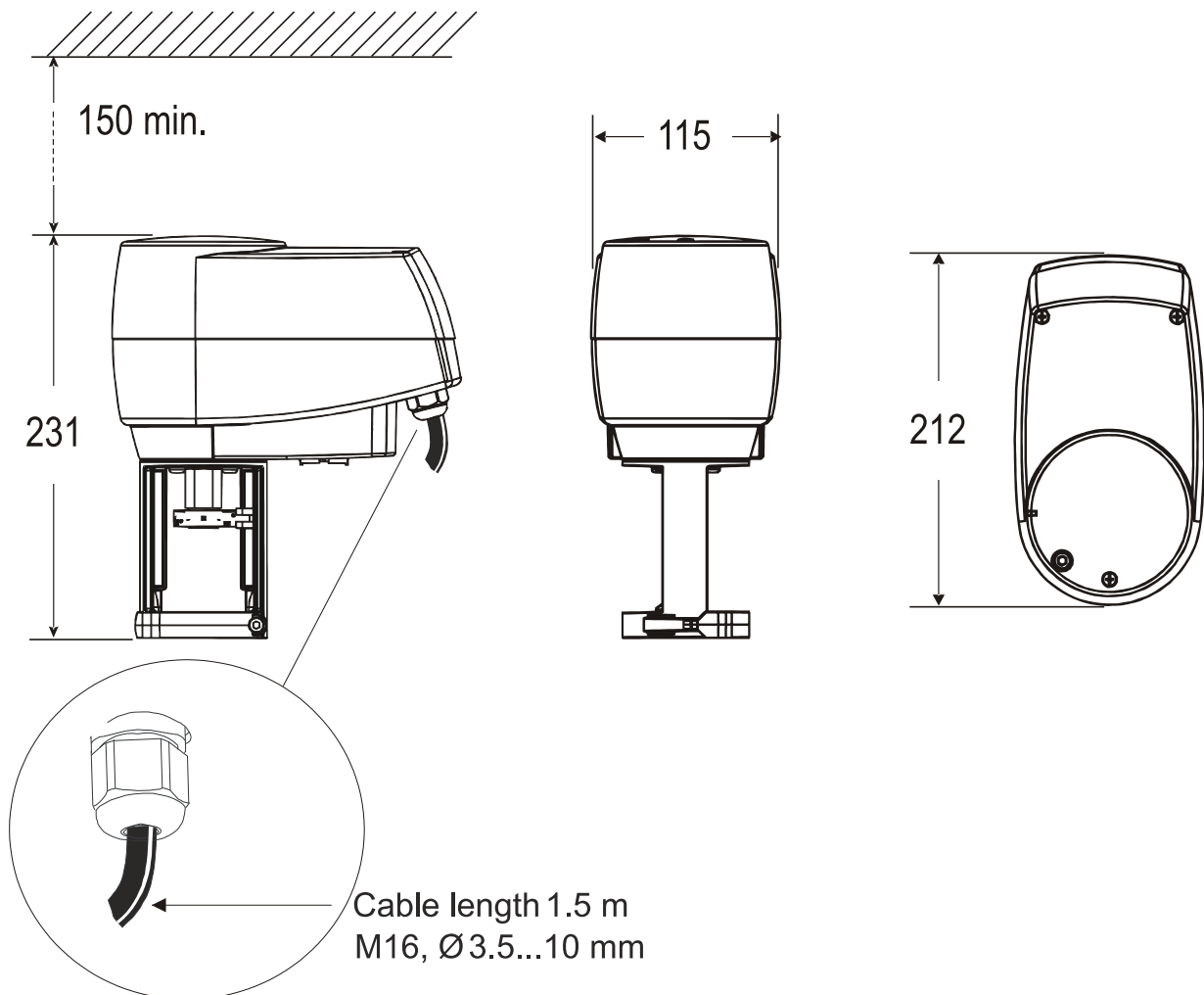

Figure 6: VA7810-AxA-xx / VA7810-AxC-xx

Dimensions (in mm)**Figure 8: Dimensions**

Ordering Data

Item Codes		Spring Return Action	Power Supply	Control	Feedback or Aux. Switches
Actuators with threaded couplers for VG7000 valves	Actuators with clamp couplers for VG8000, VG9000, VGS8000 valves				
VA7810-ADA-11	VA7810-ADA-12	no	230 VAC	On/Off or Floating	-
VA7810-ADC-11	VA7810-ADC-12				2 aux. switches
VA7810-AGA-11	VA7810-AGA-12				-
VA7810-AGC-11	VA7810-AGC-12		24 VAC	Proportional 0(2)...10 VDC / 0(4)...20 mA or Floating or On/Off	2 aux. switches
VA7810-AGH-11	VA7810-AGH-12				2 kOhm feedback potentiometer
VA7810-GGA-11	VA7810-GGA-12				0(2)...10 VDC
VA7810-GGC-11	VA7810-GGC-12				0(2)...10 VDC and 2 aux switches
VA7820-GGA-11	VA7820-GGA-12	Actuator stem retracts on power cut off	0(2)...10 VDC	0(2)...10 VDC	
VA7820-GGC-11	VA7820-GGC-12			0(2)...10 VDC and 2 aux switches	
VA7830-GGA-11	VA7830-GGA-12	Actuator stem extends on power cut off	0(2)...10 VDC	0(2)...10 VDC	
VA7830-GGC-11	VA7830-GGC-12			0(2)...10 VDC and 2 aux switches	

Ordering Procedure

The actuator can be ordered as a separate unit or a factory fitted valve-actuator combination. Should the latter be requested, please just add "+M" to the end of the actuator ordering code.

For example:

Item 1 **VG7802RT** (valve body)

Item 2 **VA7810-AGC-11** (actuator)

Alternatively, to order a factory fitted combination.

Item 1 **VG7802RT** (valve body)

Item 2 **VA7810-AGC-11+M** (actuator)

Actuator / valve combinations

The **VA78xx-xxx-11** actuators with threaded coupler can be combined with the following valve range:

- **VG7000 Series**

PN 16 Female threaded cast bronze valves

VG7 □ □ □ □ T

DN 25...50 for brass trim valve bodies

DN 15...50 for stainless steel trim valve bodies

The **VA78xx-xxx-12** actuators with clamp coupler can be combined with the following valve range:

- **VGS8... Series**

PN 16 Male threaded valves

VGS8 □ □ W1N

All body types DN15...50

- **VG9000 Series**

PN 6 and PN 10 Flanged valves

VG9 □ □ □ S1 K All body types DN15...65

VG9 □ □ □ S1 L All body types DN15...65

- **VG8000 Series**

PN 16 Flanged valves

VG8 □ □ □ V1 N All body types DN15...40

VG9 □ □ □ S1 N All body types DN15...40

PN 25 Flanged valves

VG8 □ □ □ S1 H All body types DN15...40

Technical Specifications

VA7810 Non-Spring Return Actuators

Product		VA7810	
Models	For Floating and ON/OFF Control		For Proportional, Floating and ON/OFF Control
Control signal	Position adjustment time (PAT) or ON/OFF		0(2)...10 VDC or 0(4)...20 mA or Position adjustment time (PAT) or ON/OFF
Item Codes	VA7810-ADx-1x	VA7810-AGx-1x	VA7810-GGx-1x
Supply voltage	230 V AC \pm 15% 50/60 Hz	24 V AC (19...30 V) 50/60 Hz	24 V AC (19...30 V) 50/60 Hz
Power consumption at selected speed	--- 3 W at 6 s/mm	--- 2.5 W at 6 s/mm	4.5 W at 3 s/mm 3.5 W at 6 s/mm
VA rating	8 VA	3 VA	6 VA
Impedance	---		100 k Ω min. at 0(2)...10 V 120 Ω at 0(4)...20 mA
Feedback signal	---		2 mA max. at 0(2)...10 VDC, 5 k Ω min. load
Auxiliary Switch rating	2 (1) A 250 V - Type 1B		
Thrust	1000 N + 30 / 20%		
Stroke	8 mm - 25 mm		
Nominal stroke speed	6 s/mm \pm 10%		Selectable: 3 s/mm \pm 10% 6 s/mm \pm 10%
Enclosure protection	IP54		
Protection class (with cable)	Class I (230 VAC models)	Class III (24 VAC models)	
Noise Emission at selected speed	--- 35 dB(A) at 6 s/mm		45 dB(A) at 3 s/mm 35 dB(A) at 6 s/mm
Materials			
- Gearbox & yoke	Die cast aluminium		
- Cover	Resin ABS/PC - UL94-V0		
- Stem	Stainless steel		
- Coupler	Brass		
Ambient Operating Conditions	-5 °C - 55 °C, 10% - 90% RH non-condensing		
Ambient Storage Conditions	-40 °C - 80 °C, 5% - 95% RH non-condensing		
Wiring	1.5 m cable length (0.75 mm ²) halogen free components attached per 1.5 mm ² terminal		
Wiring entrance	M16 cable adapter		
Net weight	1.7 kg		
Life time	Tested for 100,000 full cycles		
 Compliance	CE Mark, EMC Directive 89/336/EEC, Low Voltage Directive 73/23/EEC.		

Technical Specifications

VA7820 and VA7830 Spring Return Actuators

Product	VA7820 Spring Retracts VA7830 Spring Extends
Models	For ON/OFF, Floating and Proportional Control
Control signal	0(2)...10 VDC or 0(4)...20 mA or Position adjustment time (PAT) or ON/OFF
Item Codes	VA7820-GGx-1x and VA7830-GGx-1x
Supply voltage	24 V AC (19...30 V) 50/60 Hz
Power consumption at selected speed	8 W at 3 s/mm 6 W at 6 s/mm
VA rating	11 VA
Impedance	100 kΩ min. at 0(2)...10 V 120Ω at 0(4)...20 mA
Feedback signal	2 mA max. at 0(2)...10 V DC, 5 kΩ min. load
Auxiliary Switch rating	2(1) A 250 V - Type 1B
Thrust	800N min
Stroke	8 mm - 25 mm
Nominal stroke speed	Selectable: 3 s/mm ± 10% 6 s/mm ± 10%
Spring Return Stroke time	1.4 s/mm
Enclosure protection	IP54
Protection class (with cable)	Class III
Noise Emission at selected speed	45 dB(A) max peak 50 dB(A) during return spring operation
Materials	
- Gearbox & yoke	Die cast aluminium
- Cover	Resin ABS/PC - UL94-V0
- Stem	Stainless steel
- Coupler	Brass
Ambient Operating Conditions	-5 °C to 55 °C, 10% to 90% RH non-condensing
Ambient Storage Conditions	-40 °C to 80 °C, 5% to 95% RH non-condensing
Wiring	1.5 m cable length (0.75 mm ²) halogen free components attached per 1.5 mm ² terminal
Wiring entrance	M16 cable adapters
Net weight	2.5 kg
Life time	Tested for 60,000 full cycles for control and spring return operation
CE Compliance	CE Mark, EMC Directive 89/336/EEC, Low Voltage Directive 73/23/EEC.



Contact Sales at sales@ibc.ie +353 1 457 5421

