

ACVATIX™

2-port and 3-port control ball valves, PN 40, with externally threaded connection

VAG61.., VBG61..



For use in heating, ventilation, and air conditioning plants as control or shutoff valve. In closed circuits.

- Ball valve body made of brass CW602N (DZR)
- DN 15...50
- kvs 1...63 m³/h
- Flat sealing, externally threaded connections G..B, as per ISO 228-1
- Fitting sets ALG.. with threaded connection
- Rotational angle 90°
- Can be combined with electromotoric rotary actuators GQD..9A, GMA..9E with Spring return and GSD161.9A, GDB..9E, GLD161.9E, GLB..9E without spring return
- For applications with auxiliary functions (e.g. auxiliary switches, potentiometers, standard rotary actuators from the DAC product range can also be combined)

Features

- **Moderately price:**
Optimized flow rates mean smaller ball valves can be selected. Low torque means you can combine them with small, less expensive rotary actuators.
- **Long life expectancy:**
Maintenance-free construction, also thanks to low friction stem and polished ball made of chrome-plated DZR brass.
- **Simple mounting:**
The brackets, premounted on the actuators, means you can mount them on the ball valves without tools.

Technical design

Design

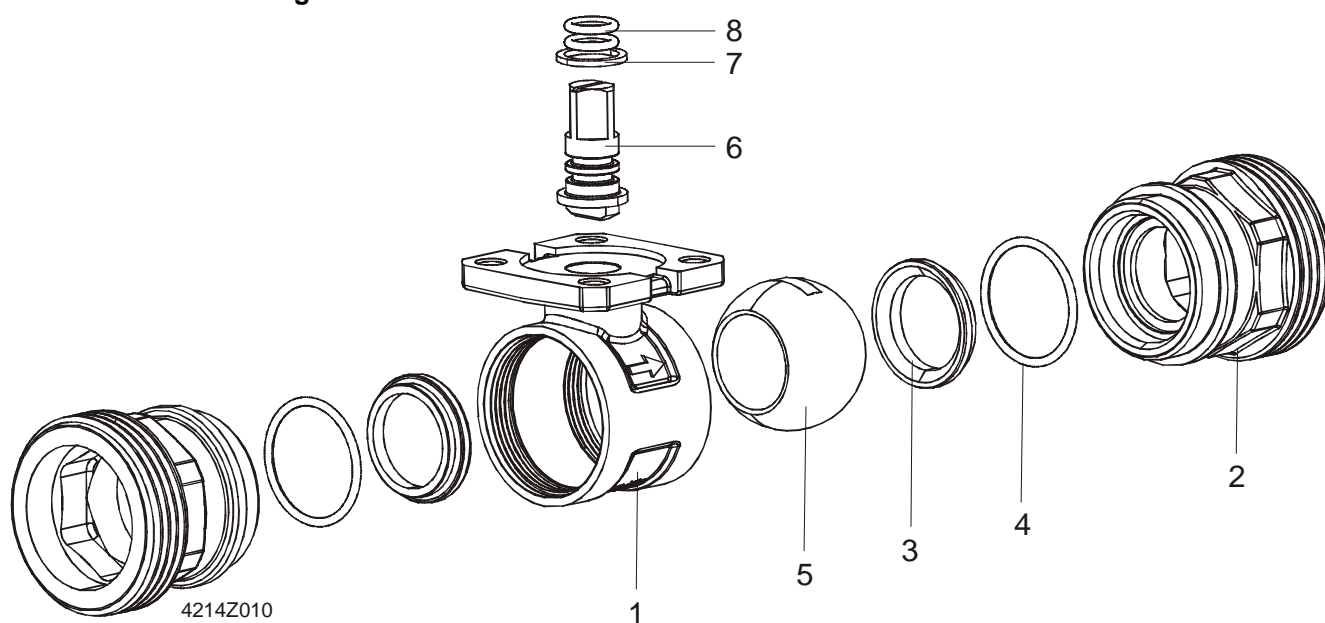

1 Housing

3 Seat

5 Marble

7 Slide clutch

2 Connection with external threading

4 O-ring seal

6 Stem, squared

8 O-ring seal

Sizing

Flow diagram:

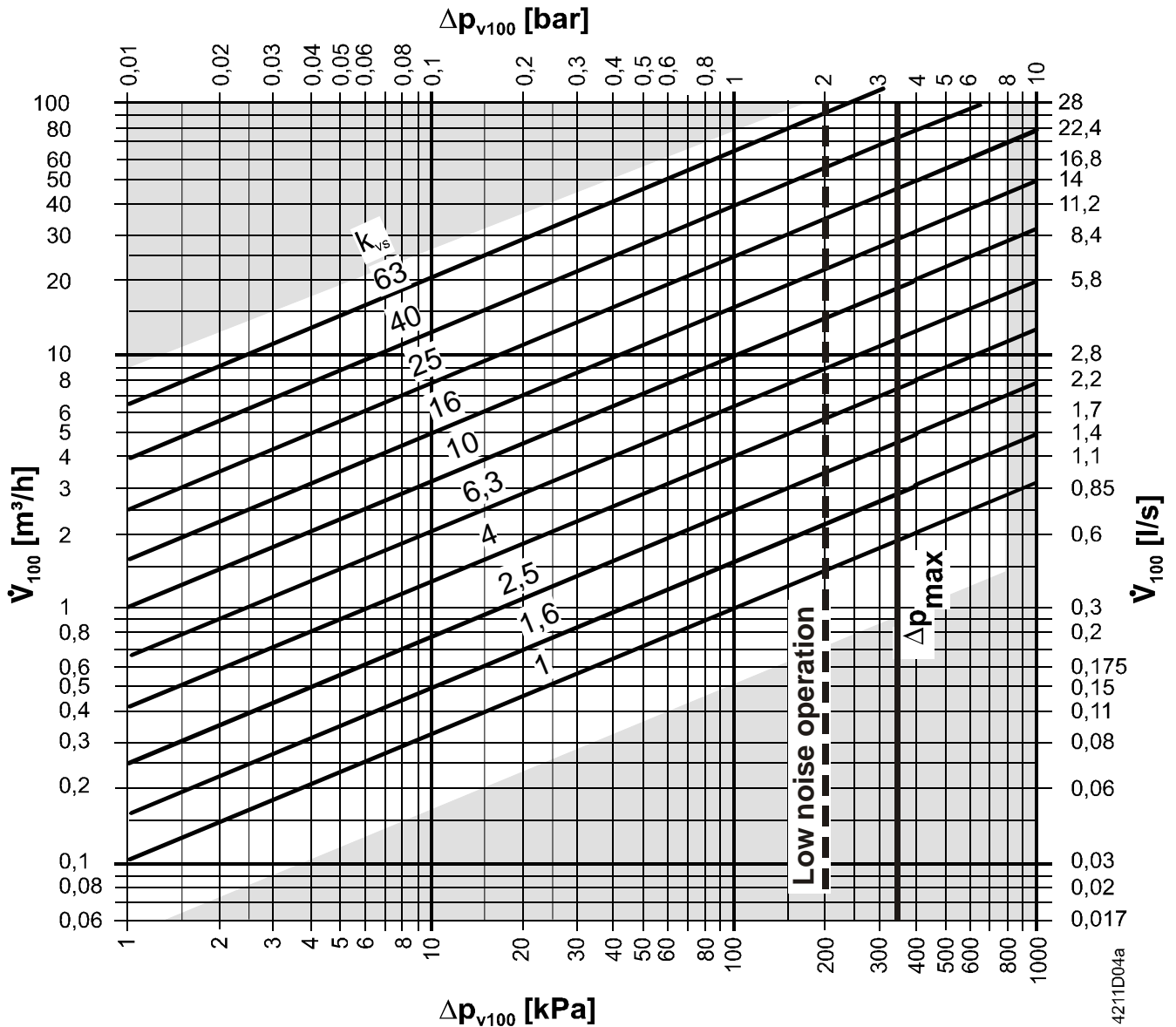

4211D004a

- Δp_{max} for VAG61.. and VBG61..., for details, see table on equipment combinations
- Δp_{max} = Maximum permissible differential pressure over the ball valve, valid for the entire positioning range of the ball valve rotary actuator unit; if low noise operation is desired, we recommend a maximum permissible differential pressure of 200 kPa
- Δp_{v100} = Differential pressure over the fully opened ball valve and over the control path at a volume flow \dot{V}_{100}
- \dot{V}_{100} = Volume flow through the fully opened ball valve
- 100 kPa = 1 bar \approx 10 mWS
- 1 m^3/h = 0.278 l/s water at 20 °C

Ball valve characteristic curve

Through-port

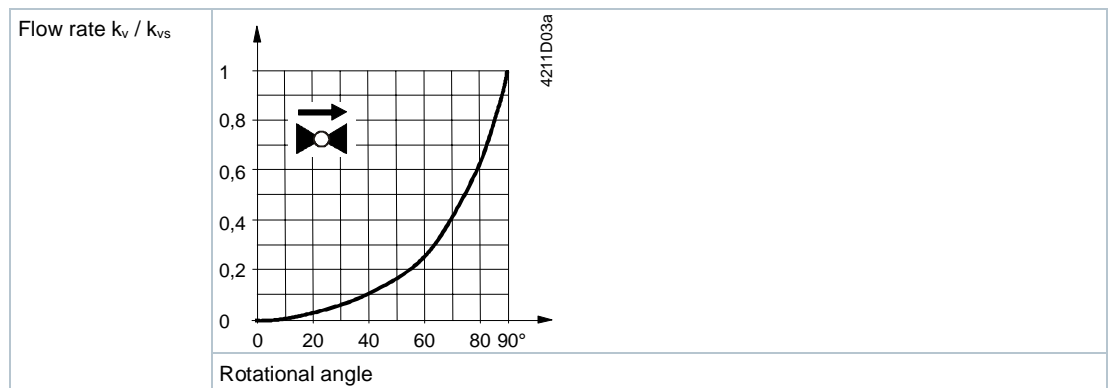

Flow characteristics

0...100 % -> A – AB equal percentage, $n_{gl} = 3.9$ per VDI / VDE 2173

3-port

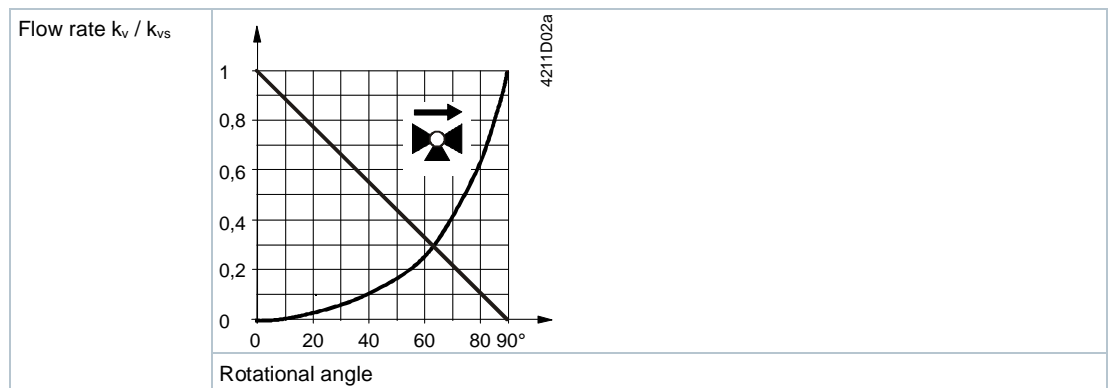

Through-port

0...100 % -> A – AB equal percentage, $n_{gl} = 3.9$ per VDI / VDE 2173

Bypass

0...100 % -> B – AB linear, k_{vs} greater than 70 % of A – AB

Cavitation

Cavitation increases wear and tear of the ball and seat and results in unwanted noise. Cavitation can be prevented by not exceeding the differential pressures as per the flow diagram and maintaining the static pressures depicted below.

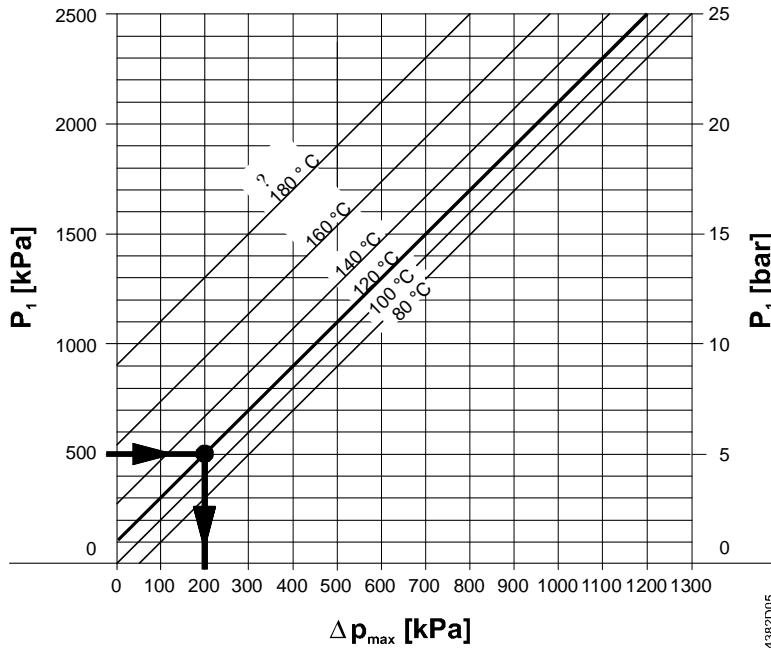

- Δp_{\max} = Differential pressure at a nearly closed ball valve to largely avoid cavitation
- p_1 = Static pressure at the ball valve inlet
- P_3 = Static pressure at the ball valve outlet
- M Pump
- J Water temperature

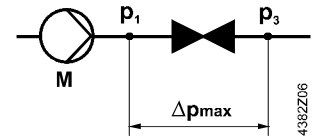

Example with hot water:

Pressure p_1 at ball valve inlet: 500 kPa (5 bar)

Water temperature: 120 °C

The above diagram clearly indicates that the maximum permissible differential pressure is $\Delta p_{\max} \rightarrow 200$ kPa (2 bar) at a nearly closed ball valve.

Note on chilled water applications

To prevent cavitation in chilled water circuits, sufficient counter pressure must be supplied to the ball valve outlet, e.g. using an additional butterfly valve downstream of the ball valve. Maximum permissible differential pressure over the ball valve: See 80 °C curve in the above diagram.

Operating pressure and operating temperature

Liquids:

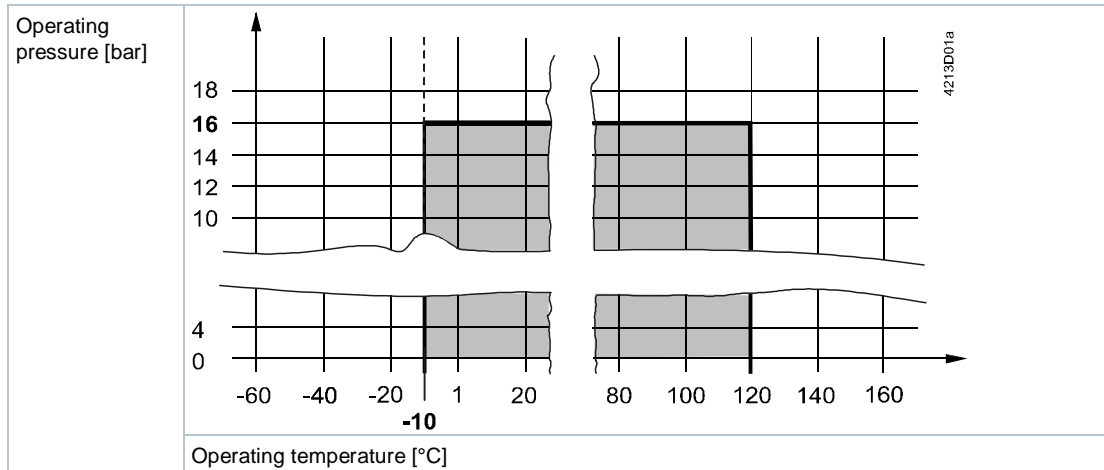

Operating pressure and medium temperature per ISO 7005
(Observe all local and applicable laws).

Type summary

Type	Stock number	Type	Stock number	DN	kvs	Sv
2-port		3-port				
VAG61.15-1	S55230-V100	—	—	15	1.0	> 500
VAG61.15-1.6	S55230-V101	VBG61.15-1.6	S55230-V120		1.6	
VAG61.15-2.5	S55230-V102	VBG61.15-2.5	S55230-V121		2.5	
VAG61.15-4	S55230-V103	VBG61.15-4	S55230-V122		4.0	
VAG61.15-6.3	S55230-V104	VBG61.15-6.3	S55230-V123		6.3	
VAG61.20-4	S55230-V105	VBG61.20-4	S55230-V124	20	4	
VAG61.20-6.3	S55230-V106	VBG61.20-6.3	S55230-V125		6.3	
VAG61.20-10	S55230-V107	—	—		10	
VAG61.25-6.3	S55230-V108	—	—	25	6.3	
VAG61.25-10	S55230-V109	VBG61.25-10	S55230-V126		10	
VAG61.25-16	S55230-V110	—	—		16	
VAG61.32-10	S55230-V111	—	—	32	10	
VAG61.32-16	S55230-V112	VBG61.32-16	S55230-V127		16	
VAG61.32-25	S55230-V113	—	—		25	
VAG61.40-16	S55230-V114	—	—	40	16	
VAG61.40-25	S55230-V115	VBG61.40-25	S55230-V128		25	
VAG61.40-40	S55230-V116	—	—		40	
VAG61.50-25	S55230-V117	—	—	50	25	
VAG61.50-40	S55230-V118	VBG61.50-40	S55230-V129		40	
VAG61.50-63	S55230-V119	—	—		63	

DN = Nominal size

k_{vs} = Flow nominal value for chilled water (5...30 °C) through a fully opened ball valve at a differential pressure of 100 kPa (1 bar)

S_v = Rangeability k_{vs} / k_{vr}

k_{vr} = The smallest kv value at which the characteristic curve tolerances can be maintained at a differential pressure of 100 kPa (1 bar)

Fittings

Type	Article number	Description
ALG..2	BPZ:ALG..2	2 piece fittings set for 2-port valves, existing of 2 cap nuts, 2 insert nuts, and 2 flat seals. ALG..2B are fittings made of brass for media temperatures up to 100 °C
ALG..2B	S55846-Z1..	
ALG..3	BPZ:ALG..3	3 piece fittings set for 3-port valves, existing of 3 cap nuts, 3 insert nuts, and 3 flat seals. ALG..3B are fittings made of brass for media temperatures up to 100 °C
ALG..3B	S55846-Z1..	

Insulation shells

Insulation shells are available for heating/cooling insulation as a separate accessory:

Type	Material	Density	Thermal conductivity at tm 40 °C	Operating temperature
ALI..V..G..	Polyethylene foam	29 kg/m ³	0.0372 W/mK	-10 °C... 100 °C

Ball valve	Insulation shell	Stock number	Ball valve	Insulation shell	Stock number
VAG61.15..	ALI15VAG60/61	S55845-Z162	VBG61.15..	ALI15VBG60/61	S55845-Z168
VAG61.20..	ALI20VAG60/61	S55845-Z163	VBG61.20..	ALI20VBG60/61	S55845-Z169
VAG61.25..	ALI25VAG60/61	S55845-Z164	VBG61.25..	ALI25VBG60/61	S55845-Z170
VAG61.32..	ALI32VAG60/61	S55845-Z165	VBG61.32..	ALI32VBG60/61	S55845-Z171
VAG61.40..	ALI40VAG60/61	S55845-Z166	VBG61.40..	ALI40VBG60/61	S55845-Z172
VAG61.50..	ALI50VAG60/61	S55845-Z167	VBG61.50..	ALI50VBG60/61	S55845-Z173

Insulation shells for shut off and changeover ball valves

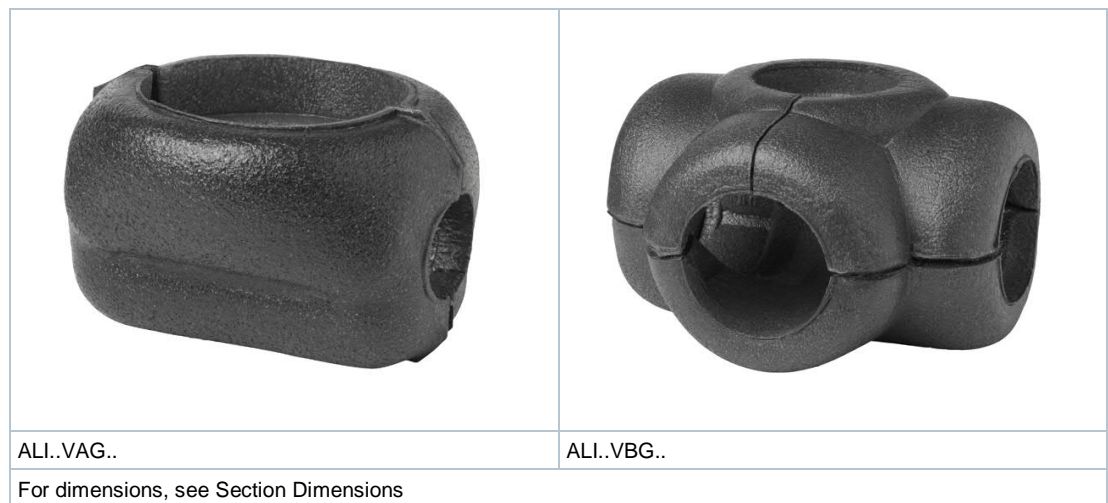

Filter

Installed upstream of the ball valve:

Type	Stock number	Description	DN	Mesh width [mm]
ALX15	S55845-Z174	Filter with internal threading	15	0.5
ALX20	S55845-Z175	Filter with internal threading	20	0.8
ALX25	S55845-Z176	Filter with internal threading	25	0.8
ALX32	S55845-Z177	Filter with internal threading	32	0.8
ALX40	S55845-Z178	Filter with internal threading	40	0.8
ALX50	S55845-Z179	Filter with internal threading	50	0.8

Equipment combinations

Type	Rotary actuators											
	GQD..9A		GSD161.9A		GDB..9E		GMA..9E		GLD161.9E		GLB..9E	
	Δp_{max}	Δp_s	Δp_{max}	Δp_s	Δp_{max}	Δp_s	Δp_{max}	Δp_s	Δp_{max}	Δp_s	Δp_{max}	Δp_s
	[kPa]											
VAG61.15..	350	1400	350	1400	350	1400	350	1400	350	1400	350	1400
VAG61.20..												
VAG61.25..												
VAG61.32-10	-	-	-	-	-	-		1000		1000		1000
VAG61.32-16	-	-	-	-	-	-						
VAG61.32-25	-	-	-	-	-	-						
VAG61.40-16	-	-	-	-	-	-		800		800		800
VAG61.40-25	-	-	-	-	-	-						
VAG61.40-40	-	-	-	-	-	-						
VAG61.50-25	-	-	-	-	-	-		600		600		600
VAG61.50-40	-	-	-	-	-	-						
VAG61.50-63	-	-	-	-	-	-						
VBG61.15..	350	—	350	—	350	—	350	—	350	—	350	—
VBG61.20..		—		—		—		—		—		—
VBG61.25-10		—		—		—		—		—		—
VBG61.32-16	—	—	—	—	—	—		—		—		—
VBG61.40-25	—	—	—	—	—	—		—		—		—
VBG61.50-40	—	—	—	—	—	—		—		—		—

Δp_{max} = Maximum permissible differential pressure over the valve ball control path, valid for the entire positioning range of the ball valve rotary actuator unit; if low noise operation is desired, we recommend a differential pressure of 200 kPa

Δp_s = Maximum permissible differential pressure (closing pressure) at which the ball valve rotary actuator unit securely closes against the pressure

Overview of rotary actuators for ball valves

Type ¹⁾	Operating voltage	Positioning		Spring return		Data sheet
		Signal	Time	Function	Time	
GQD131.9A	AC/DC 24 V	3-position	30/15 s ²⁾	Yes	15 s	N4659
GQD161.9A		DC 0...10 V				
GSD161.9A	AC/DC 24 V	DC 0...10 V	30 s	—	—	A6V10636056
GDB331.9E ³⁾	AC 230 V	3-position	150 s	—	—	N4657
GDB131.9E ³⁾	AC 24 V					
GDB161.9E ³⁾	DC 0...10 V					
GDB141.9E	AC/DC 24 V	2 or 3 point	150 s	-	-	-
GDB341.9E	AC 100-240 V					-
GDB161.9E	AC/DC 24 V					0/2...10 V
GMA131.9E	AC/DC 24 V	3-position	90/15 s ²⁾	Yes	15 s	N4658
GMA161.9E		DC 0...10 V				
GLD161.9E	AC 24 V / DC 24...48 V	DC 0/2...10 V	30 s	—	—	A6V11171770
GLB331.9E ³⁾	AC 230 V	3-position	150 s	—	—	N4657
GLB131.9E ³⁾	AC 24 V					
GLB161.9E ³⁾	DC 0...10 V					
GLB141.9E	AC/DC 24 V	2 or 3 point	150 s	-	-	A6V10636203
GLB341.9E	AC 100-240 V					
GLB161.9E	AC/DC 24 V					

¹⁾ Actuator type: Electromotive

²⁾ Open/close

³⁾ While stock lasts

Ordering

Please indicate material, article type, order text, and quantity; example:

Material	Article type	Order text	Quantity
VAG61.25-16	VAG61.25-16	Ball valve, externally threaded, 2-port	2
GLB161.9E	GLB161.9E	Actuator for ball valve, NSR	2

Delivery

Ball valves, rotary actuators, and mounting kits are not assembled and are delivered in individual packaging.

Applications with auxiliary functions

A standard actuator with corresponding functionality can be used if a ball valve application requires a rotary actuator with auxiliary functions (e.g. auxiliary switch or potentiometer). In this case, mounting kit ASK77.x is required in **addition** to the rotary actuator.

Follow the mounting instructions when mounting.

Rotary actuator	Options	Order text: Mounting kit
GMA..1E (with spring return)	Potentiometer, auxiliary switch	ASK77.2 Accessory Kit BV for GMAxx1.9E
GDB..1E / GLB..1E (without spring return)	Potentiometer, auxiliary switch	ASK77.3 Accessory Kit BV for GLBxx1.9E
GQD..1A (with spring return)	Auxiliary switch	ASK77.5 Accessory Kit BV for GQDxx1.9A
GSD..1A ¹⁾ (without spring return)	Auxiliary switch	ASK77.5 Accessory Kit BV for GSDxx1.9A

Note

¹⁾ GSD141.1A (S55499-D281) and GSD341.1A (S55499-D282) are not compatible with ball valves.

Product documentation

Related documents such as environmental declarations, CE declarations, etc., can be downloaded at the following Internet address:

<http://siemens.com/bt/download>

Notes

Safety

	<p>⚠ DANGER</p>
	<p>There is a risk to operating personnel and device when working on the unit Failure to comply with these safety notes can result in personal injury and damage to property from pipe pressure, electrical voltage, or device in operation.</p> <p>▷ Note the following when servicing a ball valve/rotary actuator:</p> <ul style="list-style-type: none"> ● Switch off both pump and operating voltage. ● Close shutoff valves. ● Release pressure in the pipes and allow them to cool down completely. ● Disconnect electrical connections from the terminals as needed. ● The rotary actuator must be properly installed prior to recommissioning the ball valve.



⚠ CAUTION

National safety regulations

Failure to comply with national safety regulations may result in personal injury and property damage.

- Observe national provisions and comply with the appropriate safety regulations.

Engineering

We recommend installing the ball valve with spring return since temperatures are lower on heating plants which increases the lifespan of the sealing gland on the stem.

Ensure there is no cavitation (see Section Technical design [→ 2]).

A filter must be installed upstream of the ball valve to increase functional safety.

Permissible media

Using the ball valve together with potassium formate-based media can result in leakage over the stem to the outside. The reason is the high level of penetration at low surface tension of media based on potassium formate.

Siemens rejects any and all liability for damages or consequential damages resulting from the use of this media together with our ball valves.

Mounting

It is easy to assemble the ball valve and rotary actuator; it can be done at the construction site. No special tools or settings required.

Ball valve VAG61.. / VBG61.. is supplied together with mounting instructions M4212 (74°319°0922°0).

Mounting position

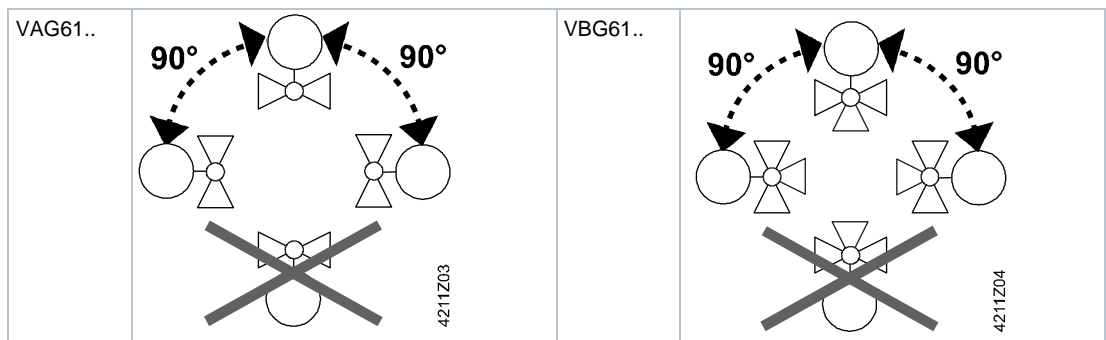



Pipe connection



Avoid leakage:

- Install fittings as per ISO 7-1. Ball valves (internal threading) = "Rp"; Piping (external threading) = "R".
- Do not use too much hemp or PTFE tape.
- Do not tighten pipe threading to the very end.
- Place the pliers/wrench on the ball valve union nut that is closer to the pipe to be tightened or loosened.

Flow direction

Make sure that the valve is mounted in the proper flow direction. A symbol is applied to the ball valve body:

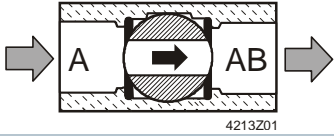
VAG61..		VBG61..	
---------	-----------------------------------------------------------------------------------	---------	-------------------------------------------------------------------------------------

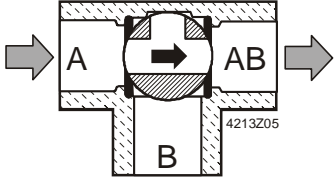
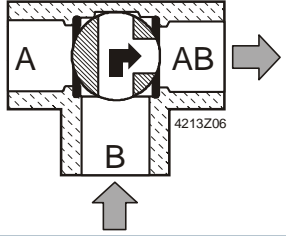
Ball valve	Laser marking	Position as delivered	90 ° turned (clockwise)
VAG61.. Control ball valve 2-port	-	 <p>A – AB = 100 %</p>	 <p>A – AB = 0 %</p>
VBG61.. Control ball valve 3-port		 <p>A – AB = 100 % B – AB = 0 %</p>	 <p>A – AB = 0 % B – AB = 100 %</p>

Maintenance

Ball valves VAG61.. and VBG61.. are maintenance free.

Disposal

Do not dispose of the device as part of domestic waste.

- Special handling of individual components may be required by law or make ecological sense.
- Adhere to all local and currently applicable laws and regulations.

Warranty

Technical data on specific applications are valid only together with Siemens products listed under "Equipment combinations". Siemens rejects any and all warranties in the event that third-party products are used.

Functional data		
	VAG61..	VBG61..
PN class	PN 40 per ISO 7268	
Operating pressure	Per ISO 7005 within the permissible media temperature as per Section Technical design [→ 2]	
Ball valve characteristic curve Through-port: 0...100 %	Equal percentage, $n_{gl} = 3.9$ per VDI / VDE 2173	
Ball valve characteristic curve Bypass: 0...100 %	—	Linear
Leakage through-port	Water proof per EN 60534-4 L/1, improved class 5	Water proof per EN 60534-4 L/1, improved class 4
Leagage bypass	-	< 1 %
Permissible media	Chilled water, low temperature hot water, hot water, water with antifreeze. Recommendation: Water treatment per VDI 2035 Note: Page 11	
Medium temperature	-10...120 °C	
Rangeability Sv	> 500	
Rotational angle	90 °	

Materials	
Ball valve body	Dezincification-resistant hot-pressed brass (DZR ¹⁾), CW602N
Marble	Dezincification-resistant hot-pressed brass (DZR ¹⁾), CW602N, chrome plated
Stem	Dezincification-resistant hot-pressed brass (DZR ¹⁾), CW602N
Sealing gland	EPDM-O rings

Dimensions / Weight	
See Dimensions [→ 14]	
Connections with external threading	G..B per ISO 228-1

Standards, directives and approvals	
Pressure Equipment Directive	DGR 2014/68/EU
Pressure accessories	Range: Article 1, para. 1 Definition: Article 2, para. 5
Fluid group 2	Without CE certification as per article 3, para. 3 (generally applicable engineering practice) ²⁾
EAC compliance	Eurasian compliance
Environmental compatibility	Environmental Declaration CE1E4212en ³⁾ contains data on environmental-compatible product design and assessment (RoHS compliance, compositions, packaging, environmental benefits and disposal).

¹⁾ Dezincification resistant

²⁾ Fittings for a product where PS x DN < 1000, do not require special testing and cannot have CE labeling

³⁾ See Section Product documentation [→ 10]

Dimensions

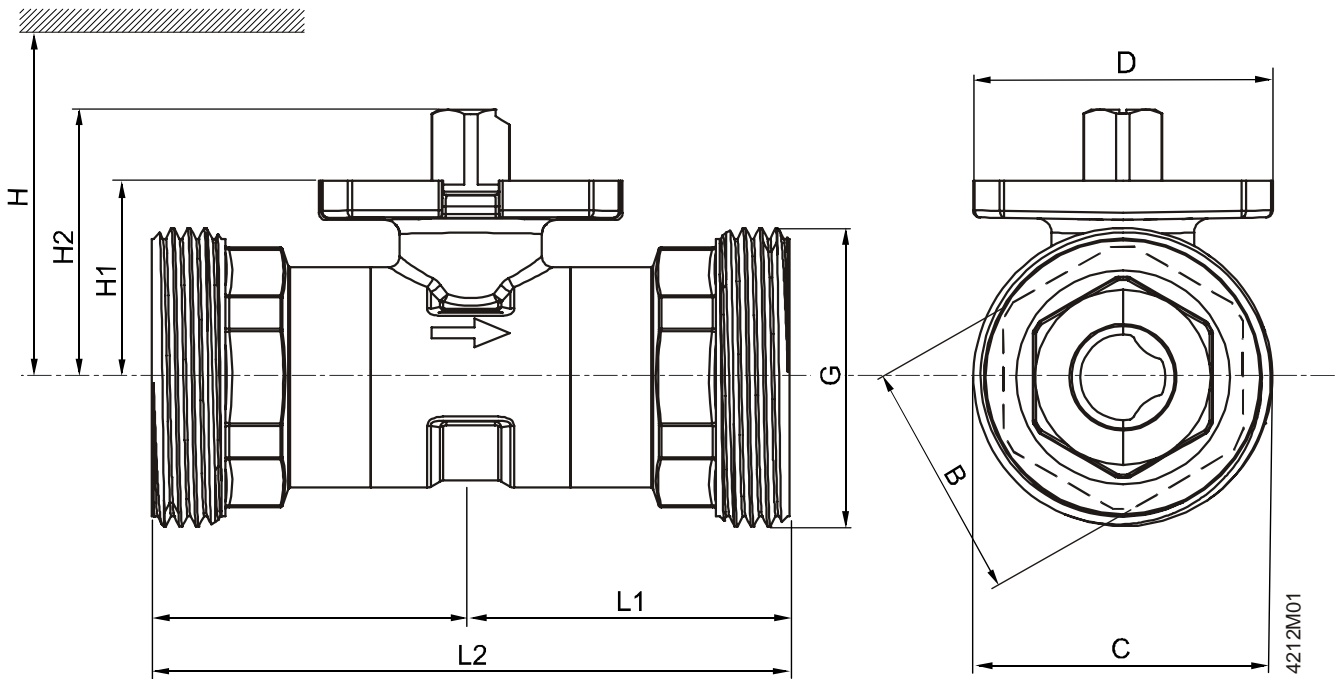

DN = Nominal size

H = Total height of actuator plus minimum mounting distance to wall or ceiling, for mounting, connection, operation, maintenance, etc.

H1 = Dimension from the pipe to the center to install actuator (upper edge)

Type	DN	B	C	D	G	L1	L2	H1	H2
		mm			Inch	mm			
VAG61.15..	15	27	33	42	G 1 B	43.5	87	27.6	37.6
VAG61.20..	20	34	42	42	G 1 ¼ B	44.7	89.4	27.6	37.6
VAG61.25..	25	35	48	42	G 1 ½ B	44.7	89.4	30.5	40.5
VAG61.32..	32	38	59.7	42	G 2 B	50.1	100.2	34.3	44.3
VAG61.40..	40	49	65.7	42	G 2 ¼ B	58.3	116.6	39.8	49.8
VAG61.50..	50	61	81.6	42	G 2 ¾ B	62	124	52.8	62.8

Type	H		Weight
	GQD..9A, GSD161.9A, GDB..9E	GMA..9E, GLD161.9E, GLB..9E	
	mm		
VAG61.15..	> 300	> 300	0,36
VAG61.20..			0,55
VAG61.25..	> 320	> 320	0,57
VAG61.32..			-
VAG61.40..	-	-	1,29
VAG61.50..	-	> 335	1,98

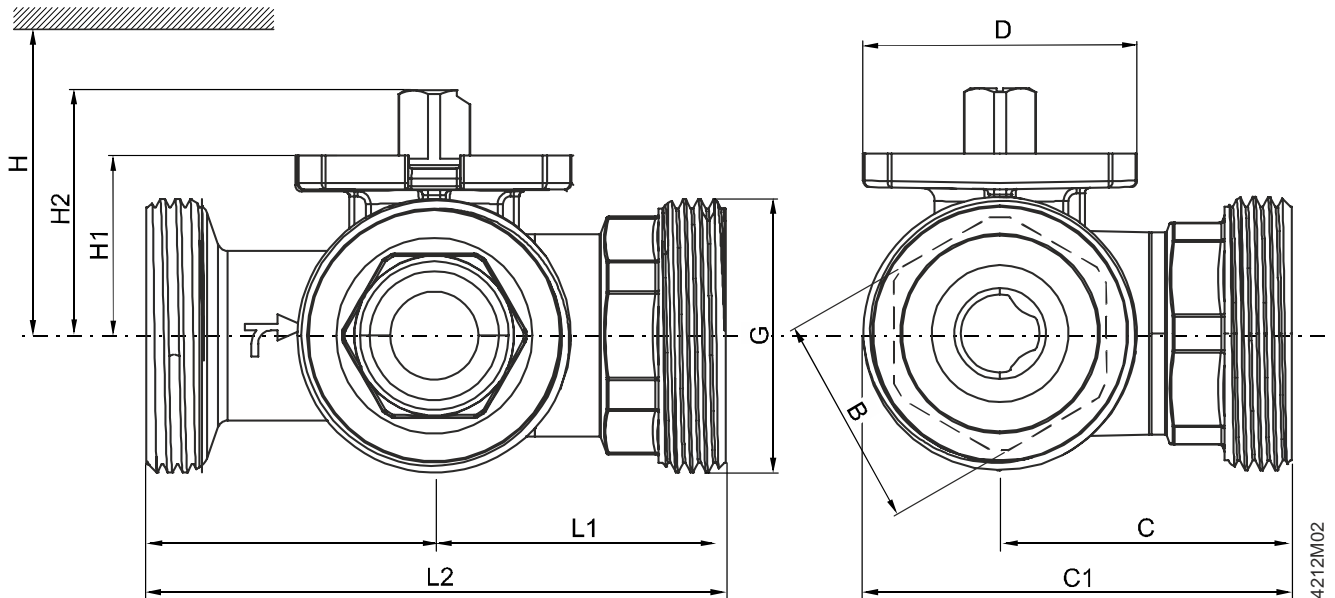

DN = Nominal size

H = Total height of actuator plus minimum mounting distance to wall or ceiling, for mounting, connection, operation, maintenance, etc.

H1 = Dimension from the pipe to the center to install actuator (upper edge)

Type	DN	B	C	C1	D	G	L1	L2	H1	H2
VBG61.15..	15	27	43.5	59.5	42	G 1 B	43.5	87	24.2	33.7
VBG61.15-6.3		27	44.1	61	42	G 1 B	44.3	88.6	27.6	37.6
VBG61.20..	20	34	44.7	66	42	G 1 ¼ B	44.7	89.4	27.6	37.6
VBG61.25..	25	35	49.5	73	42	G 1 ½ B	49.2	98.4	30.5	40.5
VBG61.32..	32	38	63.7	94	42	G 2 B	57	114	34.3	44.3
VBG61.40..	40	49	74.3	107	42	G 2 ¼ B	63.8	127.6	39.8	49.8
VBG61.50..	50	61	82.1	123	42	G 2 ¾ B	69	138	52.8	62.8

Type	H		Weight
	mm		
	GQD..9A, GSD161.9A, GDB..9E	GMA..9E, GLD161.9E, GLB..9E	
VBG61.15..	> 300		0,41
VBG61.15-6.3			0,45
VBG61.20..			0,52
VBG61.25..	> 320		0,75
VBG61.32..	-		1,2
VBG61.40..	-		1,84
VBG61.50..	-		2,83

Fittings

	For 2-port valves VAG61.. (2 piece set)		For 3-port valves VBG61.. (3 piece set)		Valve type	G	Rp
	Type	Article number	Type	Article number		Inch	Inch
	ALG152	S55846-Z100	ALG153	S55846-Z101	V..G61.15	G 1 B	Rp ½

	For 2-port valves VAG61.. (2 piece set)		For 3-port valves VBG61.. (3 piece set)		Valve type	G	Rp
	Type	Article number	Type	Article number		Inch	Inch
	ALG202	S55846-Z102	ALG203	S55846-Z103	V..G61.20	G 1¼B	Rp ¾
	ALG252	S55846-Z104	ALG253	S55846-Z105	V..G61.25	G 1½B	Rp 1
	ALG322	S55846-Z106	ALG323	S55846-Z107	V..G61.32	G 2B	Rp 1¼
	ALG402	S55846-Z108	ALG403	S55846-Z109	V..G61.40	G 2¼B	Rp 1½
	ALG502	S55846-Z110	ALG503	S55846-Z111	V..G61.50	G 2¾B	Rp 2

- Valve side with cylindrical threading per ISO 228-1
- Pipe side with cylindrical threading per ISO 7-1
- ALG..B fittings up to 100 °C medium temperature

Insulation shells for 2-port control ball valves (VAG61..)

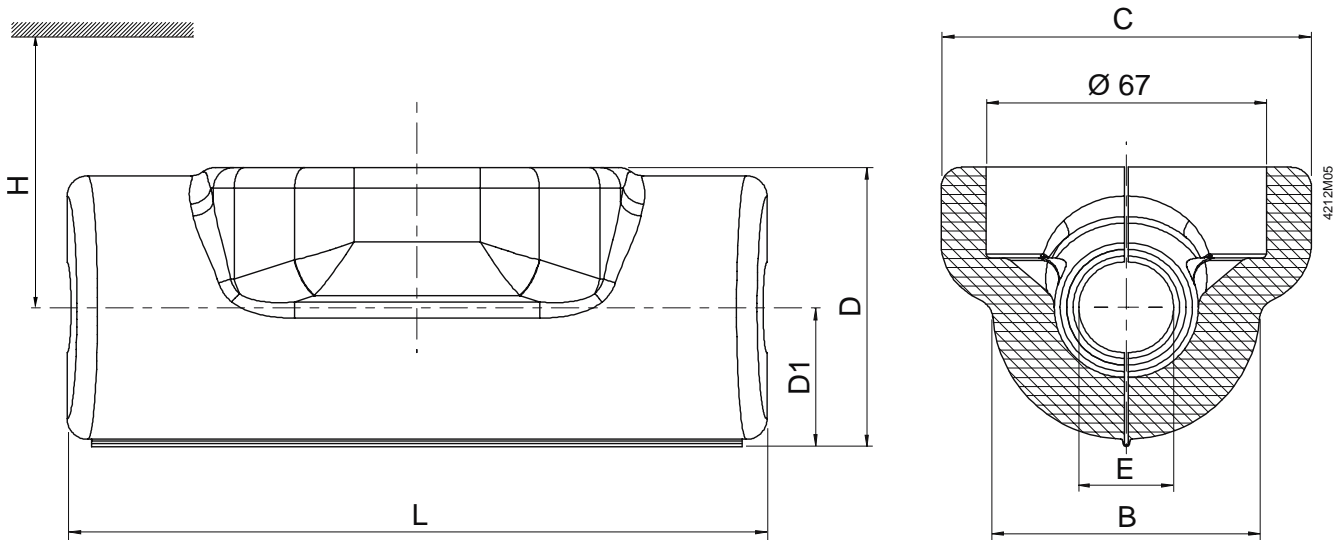

DN = Nominal size

H = Total height of actuator plus minimum mounting distance to wall or ceiling, for mounting, connection, operation, maintenance, etc.

Type		DN	B	C	D	D1	E	L
Insulation shell	For ball valve	mm						
ALI15VAG60/61	VAG61.15..	15	64	92	66	32	21	170
ALI20VAG60/61	VAG61.20..	20	80	88	88	42	27	170
ALI25VAG60/61	VAG61.25..	25	90	95	100	48	34	185
ALI32VAG60/61	VAG61.32..	32	102	100	108	54	43	185
ALI40VAG60/61	VAG61.40..	40	118	105	124	60	48	215
ALI50VAG60/61	VAG61.50..	50	130	110	134	66	61	225

Type		H		Weight
Insulation shells	For ball valve	GQD..9A, GSD161.9A, GDB..9E	GMA..9E, GLD161.9E, GLB..9E	
		mm		g
ALI15VAG60/61	VAG60.15..	> 300	> 300	24
ALI20VAG60/61	VAG60.20..			30
ALI25VAG60/61	VAG60.25..	> 320	> 320	32
ALI32VAG60/61	VAG60.32..	-		40
ALI40VAG60/61	VAG60.40..	-		52
ALI50VAG60/61	VAG60.50..	-	> 335	59

Insulation shells for 3-port control ball valves (VBG61..)

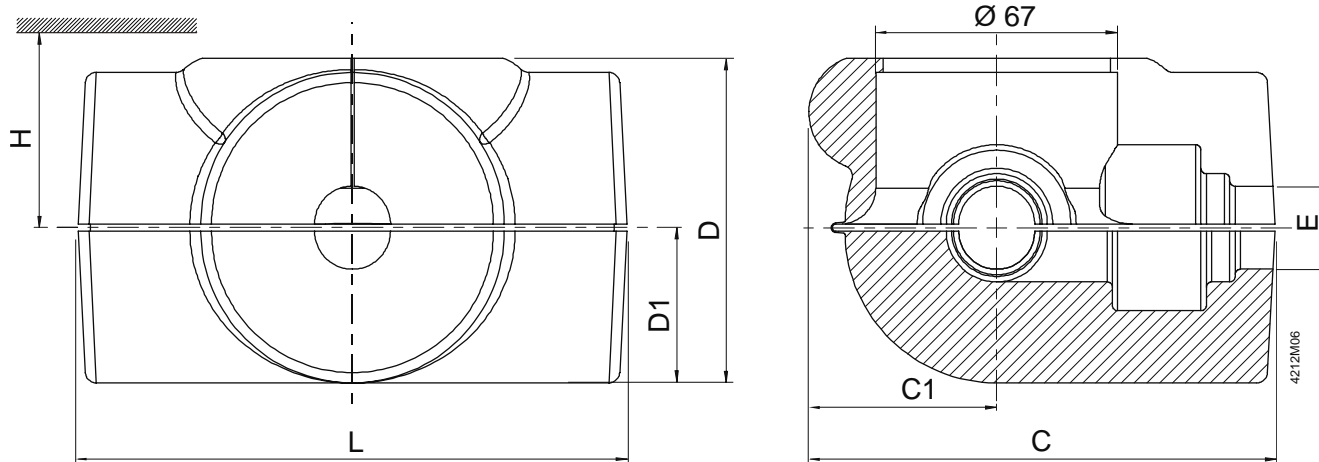

DN = Nominal size

H = Total height of actuator plus minimum mounting distance to wall or ceiling, for mounting, connection, operation, maintenance, etc.

Type		DN	C	C1	D	D1	E	L
Insulation shell	For ball valve							
		mm						
ALI15VBG60/61	VBG61.15..	15	132	50	87	42	21	155
ALI20VBG60/61	VBG61.20..	20	135	58	97	49	27	170
ALI25VBG60/61	VBG61.25..	25	145	51	104	51	34	185
ALI32VBG60/61	VBG61.32..	32	175	61	124	60	43	210
ALI40VBG60/61	VBG61.40..	40	185	61	130	63	48	225
ALI50VBG60/61	VBG61.50..	50	195	65	138	67	61	235

Type		H		Weight
Insulation shells	For ball valve	GQD..9A, GSD161.9A, GDB..9E	GMA..9E, GLD161.9E, GLB..9E	
		mm		g
ALI15VBG60/61	VBG61.15..	> 300	> 300	45
ALI20VBG60/61	VBG61.20..			55
ALI25VBG60/61	VBG61.25..	> 320	> 320	65
ALI32VBG60/61	VBG61.32..	-		88
ALI40VBG60/61	VBG61.40..	-		105
ALI50VBG60/61	VBG61.50..	-	> 335	115

Filter

	Type	DN	b	c	G	L	H	K _{vs}	Weight
			mm	mm	Inch ¹⁾	mm	mm		kg
	ALX15	15	12	38	G ½	54	27	3.5	0.178
	ALX20	20	15	43	G ¾	67	34	5.8	0.290
	ALX25	25	16	53	G 1	79	41	9.1	0.410
	ALX32	31	17	64	G 1 ¼	98	51	19	0.680
	ALX40	40	18	70	G 1 ½	106	57	24	0.874
	ALX50	50	20	85	G 2	122	69	36	1.428

¹⁾ ISO 228-1

Revision numbers

Type	Valid from rev. no.	Type	Valid from rev. no.
Shutoff ball valve VAG61..		Changeover ball valve VBG61..	
2-port		3-port	
VAG61.15-1	..A	—	..A
VAG61.15-1.6	..A	VBG61.15-1.6	..A
VAG61.15-2.5	..A	VBG61.15-2.5	..A
VAG61.15-4	..A	VBG61.15-4	..A
VAG61.15-6.3	..A	VBG61.15-6.3	..A
VAG61.20-4	..A	VBG61.20-4	..A
VAG61.20-6.3	..A	VBG61.20-6.3	..A
VAG61.20-10	..A	—	..A
VAG61.25-6.3	..A	—	..A
VAG61.25-10	..A	VBG61.25-10	..A
VAG61.25-16	..A	—	..A
VAG61.32-10	..A	—	..A
VAG61.32-16	..A	VBG61.32-16	..A
VAG61.32-25	..A	—	..A
VAG61.40-16	..A	—	..A
VAG61.40-25	..A	VBG61.40-25	..A
VAG61.40-40	..A	—	..A
VAG61.50-25	..A	—	..A
VAG61.50-40	..A	VBG61.50-40	..A
VAG61.50-63	..A	—	..A