

Cloud capable and communicative rotary actuator for ball valves

- Torque motor 5 Nm
- Nominal voltage AC/DC 24 V
- Control modulating, communicative, hybrid, Cloud
- Conversion of sensor signals
- Ethernet 10/100 Mbit/s, TCP/IP, integrated web server
- Communication via BACnet IP, Modbus TCP and Cloud

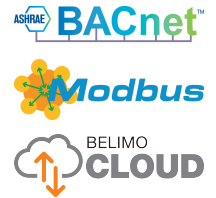

### Technical data

<b>Electrical data</b>	Nominal voltage	AC/DC 24 V
	Nominal voltage frequency	50/60 Hz
	Nominal voltage range	AC 19.2...28.8 V / DC 21.6...28.8 V
	Power consumption in operation	3.5 W
	Power consumption in rest position	3 W
	Power consumption for wire sizing	5 VA
	Connection supply / control	Cable 1 m, 6 x 0.5 mm <sup>2</sup>
	Connection Ethernet	RJ45 socket
	Parallel operation	Yes (note the performance data)
<b>Functional data</b>	Torque motor	5 Nm
	Communicative control	Cloud BACnet IP Modbus TCP
	Operating range Y	2...10 V
	Input Impedance	34 kΩ
	Operating range Y variable	0.5...10 V
	Position accuracy	±5%
	Manual override	with push-button, can be locked
	Running time motor	90 s / 90°
	Running time motor variable	35...420 s
	Adaptation setting range	manual
	Sound power level, motor	35 dB(A)
	Position indication	Mechanically, pluggable
	<b>Safety data</b>	Protection class IEC/EN
Degree of protection IEC/EN		IP40
Degree of protection note		IP54 when using protective cap or protective grommet for RJ45 socket
EMC		CE according to 2014/30/EU
Mode of operation		Type 1
Rated impulse voltage supply / control		0.8 kV
Control pollution degree		3
Ambient temperature		-30...50°C
Storage temperature		-40...80°C
Ambient humidity		Max. 95% r.H., non-condensing
Servicing		maintenance-free
<b>Weight</b>	Weight	0.56 kg

### Safety notes



- The device must not be used outside the specified field of application, especially not in aircraft or in any other airborne means of transport.
- Outdoor application: only possible in case that no (sea) water, snow, ice, insulation or aggressive gases interfere directly with the device and that it is ensured that the ambient conditions remain within the thresholds according to the data sheet at any time.
- Only authorised specialists may carry out installation. All applicable legal or institutional installation regulations must be complied during installation.
- The device may only be opened at the manufacturer's site. It does not contain any parts that can be replaced or repaired by the user.
- Cables must not be removed from the device.
- To calculate the torque required, the specifications supplied by the damper manufacturers concerning the cross-section, the design, the installation site and the ventilation conditions must be observed.
- The device contains electrical and electronic components and must not be disposed of as household refuse. All locally valid regulations and requirements must be observed.

**Product features**

**Mode of operation** The actuator is controlled via the Cloud, BACnet IP or Modbus TCP and drives to the position defined by the control signal. Various data points can be written and read via the same interfaces.

Hybrid mode:

The actuator receives its analog control signal from the higher level controller and drives to the position defined. Using the Cloud, BACnet IP or Modbus TCP, various data points can be read and with the exception of the control signal written.

**Converter for sensors** Connection option for two sensors (passive sensor, active sensor or switching contact). The actuator serves as an analogue/digital converter for the transmission of the sensor signal to the higher level system.

**Communication** The parametrisation can be carried out through the integrated web server (RJ45 connection to the web browser), by communicative means or via the Cloud.

Additional information regarding the integrated web server can be found in the separate documentation.

**"Peer to Peer" connection**

<http://belimo.local:8080>

The Notebook must be set to "DHCP".

Make sure that only one network connection is active.

**Standard IP address:**

<http://192.168.0.10:8080>

Static IP address

**Password (read-only):**

User name: «guest»

Password: «guest»

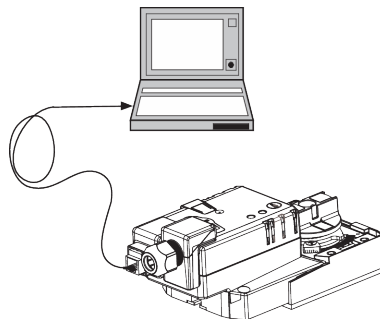

**Simple direct mounting** Straightforward direct mounting on the ball valve with only one central screw. The assembly tool is integrated in the plug-in position indication. The mounting orientation in relation to the ball valve can be selected in 90° steps.

**Data recording** The recorded data (integrated data recording for 13 months) can be used for analytical purposes. Download csv files via web browser.

**Manual override** Manual override with push-button possible (the gear is disengaged for as long as the button is pressed or remains locked).

**Adjustable angle of rotation** Adjustable angle of rotation with mechanical end stops.

**High functional reliability** The actuator is overload protected, requires no limit switches and automatically stops when the end stop is reached.

**Home position** The first time the supply voltage is switched on, i.e. at the time of commissioning, the actuator carries out an adaption, which is when the operating range and position feedback adjust themselves to the mechanical setting range.  
The actuator then moves into the position defined by the positioning signal.

**Adaptation and synchronisation**

An adaption can be triggered manually by pressing the "Adaption" button. Both mechanical end stops are detected during the adaption (entire setting range).

The actuator then moves into the position defined by the positioning signal.

**Accessories**

Electrical accessories	Description	Type
	Grommet for RJ connection module, 50 pcs.	Z-STRJ.1
	Connection cable 5 m, A: RJ11 6/4 ZTH EU, B: 6-pin for connection to service socket	ZK1-GEN
Service tools	Description	Type
	Service Tool, with ZIP-USB function, for parametrisable and communicative Belimo actuators, VAV controller and HVAC performance devices	ZTH EU

**Electrical installation**

**Supply from isolating transformer.**

**Parallel connection of other actuators possible. Observe the performance data.**

**Wiring diagrams**

AC/DC 24 V

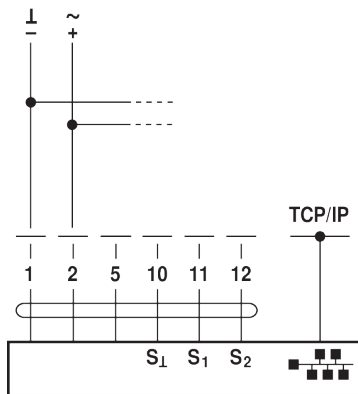
**Cable colours:**

- 1 = black
- 2 = red
- 5 = orange
- 10 = yellow-black
- 11 = yellow-pink
- 12 = yellow-grey



Connection of a notebook for parametrisation and manual control via RJ45.

Optional connection via RJ45 (direct connection Notebook / connection via Intranet or Internet) for access to the integrated web server

**Functions**



**The connection diagrams shows connections for the first sensor on terminal S1, while the second sensor can be connected identically on terminal S2.**

**Parallel use of different sensor types is permitted.**

**For hybrid operation, S1 is used for the control signal Y and must be configured as an active sensor.**

**Functions for actuators with specific parameters (Parametrisation necessary)**

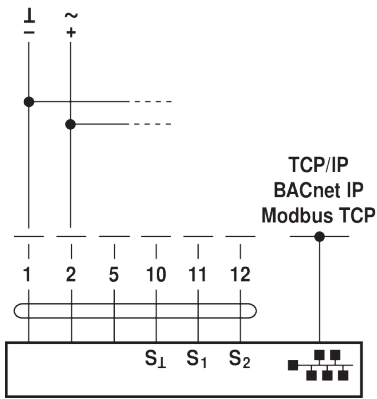
TCP/IP (Cloud) / BACnet IP / Modbus TCP



Connection of passive sensors

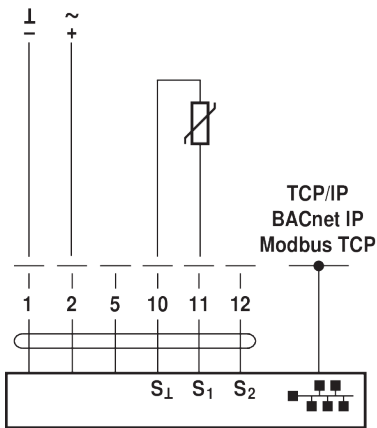

Switching contact connection

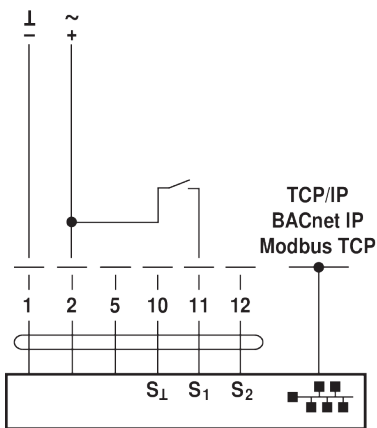

TCP/IP (Cloud) / BACnet IP / Modbus TCP with analogue setpoint (hybrid operation)

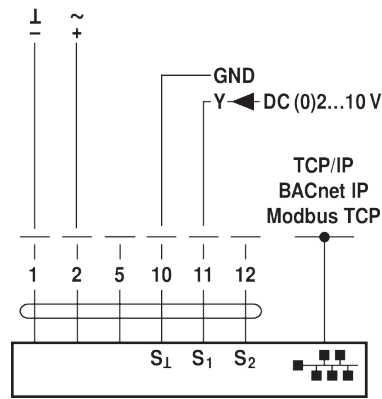

Connection of active sensors

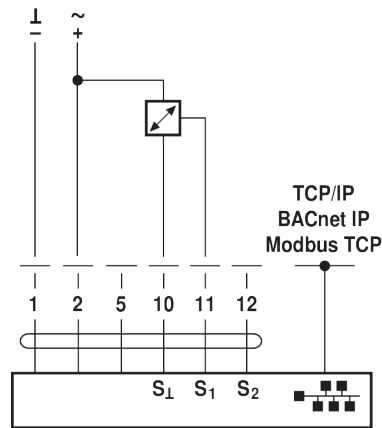

**Operating controls and indicators**

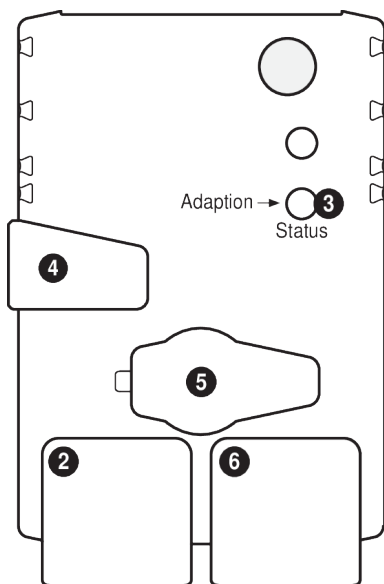

- 2 LED display green**  
 Off: No power supply or wiring errors  
 On: Actuator starts operation  
 Flickering: In operation
- 3 Push-button and LED display orange**  
 Off: Standard mode  
 On: Adaptation or synchronising process active  
 Press button: Triggers angle of rotation adaptation, followed by standard mode
- 4 Gear disengagement button**  
 Press button: Gear disengages, motor stops, manual override possible  
 Release button: Gear engages, synchronisation starts, followed by standard mode
- 5 Service plug**  
 For the connection of ZTH EU
- 6 RJ45 socket**  
 For the connection of TCP/IP (Cloud), BACnet IP and Modbus TCP

## Dimensions

## Dimensional drawings

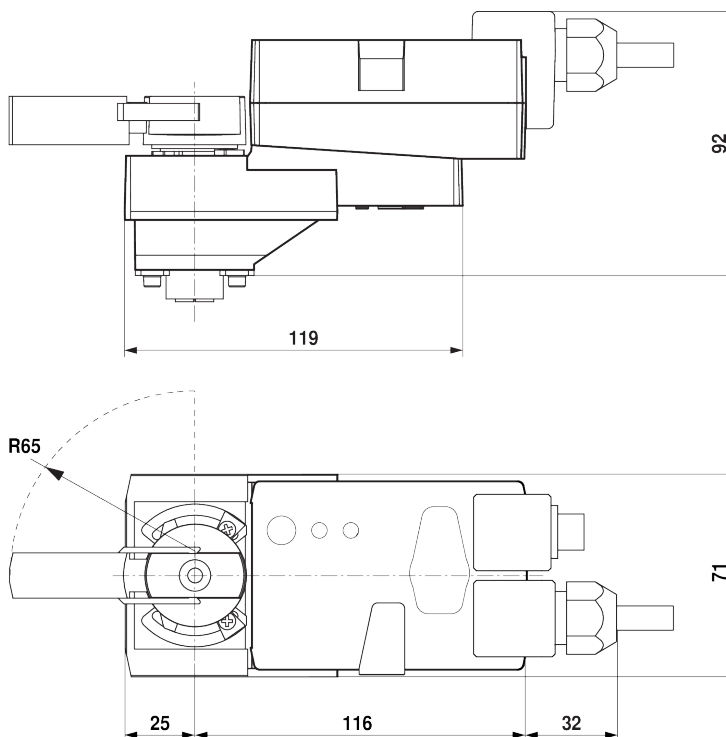

## Further documentation

- General notes for project planning
- Instruction Webserver
- Description Protocol Implementation Conformance Statement PICS
- Description Modbus register
- Description clientAPI