



VVF22..



VXF22..

ACVATIX™

## 2- and 3-port valves with flanged connections, PN 6

VVF22..  
VXF22..

From the large-stroke valve line

- Performance valves for medium temperatures from -10...130 °C
- Valve body of grey cast iron EN-GJL-250
- DN 25...100
- $k_{vs}$  2.5...160 m<sup>3</sup>/h
- Flange type 21, flange design B
- Equipable with electro-motoric actuators SAX.., SAV.. or electro-hydraulic actuators SKD.., SKB.., SKC..

### Use

In boiler, refrigeration plants, heating groups, ventilation and air-handling units as control or shutoff valves.

For use in closed circuits.

## Type summary

Valves	Actuators				SAX..		SKD..		SKB..		SAV..		SKC..	
	Stroke				800 N		20 mm		2800 N		40 mm		2800 N	
PN 6	Positioning force				800 N		1000 N		2800 N		1600 N		2800 N	
	Data sheet				N4501		N4561		N4564		N4503		N4566	
	Stock number	DN	k <sub>vs</sub> [m <sup>3</sup> /h]	S <sub>v</sub>	Δp <sub>s</sub>	Δp <sub>max</sub>	Δp <sub>s</sub>	Δp <sub>max</sub>	Δp <sub>s</sub>	Δp <sub>max</sub>	Δp <sub>s</sub>	Δp <sub>max</sub>	Δp <sub>s</sub>	Δp <sub>max</sub>
-10...130 °C														
VVF22.25-2.5	S55200-V100	25	2.5	> 50	600	300	600	300	600	300	-	-	-	-
VVF22.25-4	S55200-V101	25	4											
VVF22.25-6.3	S55200-V102	25	6.3											
VVF22.25-10	S55200-V103	25	10											
VVF22.40-16	S55200-V104	40	16	> 100	550	300	450	200	450	600	300	-	-	
VVF22.40-25	S55200-V105	40	25											
VVF22.50-40	S55200-V106	50	40											
VVF22.65-63	S55200-V107	65	63											
VVF22.80-100 <sup>1)</sup>	S55200-V108	80	100											
VVF22.100-160 <sup>1)</sup>	S55200-V109	100	160											

Valves	Actuators				SAX..		SKD..		SKB..		SAV..		SKC..	
	Stroke				800 N		20 mm		2800 N		40 mm		2800 N	
PN 6	Positioning force				800 N		1000 N		2800 N		1600 N		2800 N	
	Data sheet				N4501		N4561		N4564		N4503		N4566	
	Stock number	DN	k <sub>vs</sub> [m <sup>3</sup> /h]	S <sub>v</sub>	Δp <sub>max</sub> [kPa]									
-10...130 °C					A→B	AB→A	A→B	AB→A	A→B	AB→A	A→B	AB→A	A→B	AB→A
VXF22.25-2.5	S55200-V110	25	2.5	> 50	300	100	300	100	300	100	-	-	-	-
VXF22.25-4	S55200-V111	25	4											
VXF22.25-6.3	S55200-V112	25	6.3											
VXF22.25-10	S55200-V113	25	10											
VXF22.40-16	S55200-V114	40	16	> 100	150	50	200	80	-	-	300	100	-	-
VXF22.40-25	S55200-V115	40	25											
VXF22.50-40	S55200-V116	50	40											
VXF22.65-63	S55200-V117	65	63											
VXF22.80-100 <sup>1)</sup>	S55200-V118	80	100											
VXF22.100-160 <sup>1)</sup>	S55200-V119	100	160											

<sup>1)</sup> Valve characteristic for k<sub>vs</sub> value 100 m<sup>3</sup>/h from 70% stroke, k<sub>vs</sub> value 160 m<sup>3</sup>/h from 85% is optimized for maximum volumetric flow

DN = Nominal size

k<sub>vs</sub> = Flow nominal value of cold water (5...30 °C) through the fully opened valve (H<sub>100</sub>) at a differential pressure of 100 kPa (1 bar)

S<sub>v</sub> = Rangeability

Δp<sub>s</sub> = Maximum permissible differential pressure at which the motorized valve still closes securely against the pressure

Δp<sub>max</sub> = Maximum permissible differential pressure across the valve's throughport for the entire positioning range of the motorized valve

## Ordering

### Example

Product number	Stock number	Description
VVF22.25-2.5	S55200-V100	2-port valve with flange, PN 6
SKD32.50	SKD32.50	Electro-hydraulic actuator

### Delivery

Valves, actuators and accessories are packed and delivered as separate items.

### Note

Counter-flanges, bolts and gaskets must be provided on site.

### Spare parts, Rev.-No.

See page 11

## Equipment combinations

Product number	Description	Stroke	Positioning force	Operating voltage	Positioning signal	Spring return time	Positioning time	LED	Manual adjuster	Auxiliary functions						
SAX31.00	S55150-A105	20 mm	800 N	AC 230 V	3-position	-	120 s	-	Press and fix	1) 2) 5)						
SAX31.03	S55150-A106						30 s				✓	1) 3) 5) 6)				
SAX61.03	S55150-A100			AC 24 V DC 24 V	DC 0...10 V DC 4...20 mA 0...1000 Ω	-	120 s	-		1) 2) 5)						
SAX61.03U	S55150-A100-A100										30 s	✓	1) 3) 5) 6)			
SAX81.00	S55150-A102			AC 24 V DC 24 V	3-position	-	120 s	-		1) 2) 5)						
SAX81.03	S55150-A103										30 s	✓	1) 3) 5) 6)			
SAX81.03U	S55150-A103-A100	30 s	✓	1) 3) 5) 6)												
SKD32.21	SKD32.21	20 mm	1000 N	AC 230 V	3-position	8 s	Opening: 30 s Closing: 10 s	-	Turn, Position is maintained	1) 2) 5) 7)						
SKD32.50	SKD32.50					-	120 s				1) 5) 7)					
SKD32.51	SKD32.51					8 s	120 s									
SKD60	SKD60			AC 24 V	DC 0...10 V DC 4...20 mA 0...1000 Ω	-	15 s	Opening: 30 s Closing: 15 s		✓	1) 5) 7)					
SKD60U	SKD60U											1) 4) 5) 7)				
SKD62	SKD62											3-position	-	120 s	-	1) 2) 5) 7)
SKD62U	SKD62U															
SKD62UA	SKD62UA			8 s	120 s	1) 2) 5) 7)										
SKD82.50	SKD82.50			20 mm	2800 N	AC 230 V	3-position	-		120 s	-	Turn, Position is maintained	1) 2) 5) 7)			
SKD82.50U	SKD82.50U							10 s								
SKB32.50	SKB32.50	10 s	120 s					1) 2) 5) 7)								
SKB60	SKB60	AC 24 V	DC 0...10 V AC 4...20 mA 0...1000 Ω			-	10 s	Opening: 120 s Closing: 10 s	✓	1) 5) 7)						
SKB62	SKB62										10 s		120 s	1) 4) 5) 7)		
SKB62U	SKB62U										10 s		120 s	1) 2) 5) 7)		
SKB62UA	SKB62UA										10 s		120 s	1) 2) 5) 7)		
SKB82.50	SKB82.50	AC 24 V	3-position	-	10 s	120 s	-	1) 2) 5) 7)								
SKB82.50U	SKB82.50U								10 s	120 s	1) 2) 5) 7)					
SKB82.51	SKB82.51								10 s	120 s	1) 2) 5) 7)					
SKB82.51U	SKB82.51U	10 s	120 s	1) 2) 5) 7)												
SAV31.00	S55150-A112	40 mm	1600 N	AC 230 V	3-position	-	120 s	-	Press and fix	1) 2) 5)						
SAV61.00	S55150-A110										AC 24 V DC 24 V	DC 0...10 V DC 4...20 mA 0...1000 Ω	-	120 s	✓	1) 3) 5) 6)
SAV61.00U	S55150-A110-A100			3-position	-	120 s	-	1) 2) 5)								
SAV81.00	S55150-A111									3-position	120 s	1) 2) 5)				
SAV81.00U	S55150-A111-A100	3-position	120 s	1) 2) 5)												
SKC32.60	SKC32.60	40 mm	2800 N	AC 230 V	3-position	-	120 s	-	Turn, Position is maintained	1) 2) 5)						
SKC32.61	SKC32.61					18 s										
SKC60	SKC60					18 s										
SKC62	SKC62			AC 24 V	DC 0...10 V DC 4...20 mA 0...1000 Ω	-	20 s	Opening: 120 s Closing: 20 s		✓	1) 5)					
SKC62U	SKC62U											20 s	120 s	1) 4) 5)		
SKC62UA	SKC62UA											20 s	120 s	1) 4) 5)		
SKC82.60	SKC82.60											3-position	-	120 s	-	1) 2) 5)
SKC82.60U	SKC82.60U	18 s	120 s	1) 2) 5)												
SKC82.61	SKC82.61	18 s	120 s	1) 2) 5)												
SKC82.61U	SKC82.61U	18 s	120 s	1) 2) 5)												

- 1) Auxiliary switch (optional)
- 2) Potentiometer (optional)
- 3) Position feedback, forced control, selection of valve characteristic
- 4) Direction of operation, stroke limit control, sequence control, signal addition (optional)
- 5) Stem heating element (optional)
- 6) Function module (optional)
- 7) Mechanical stroke inverter (optional)

## Product documentation

- Mounting Instructions M4030 74 319 0749 0
- Basic documentation P4030 Contains background information and technical basic knowledge of valves

## Technical and mechanical design

The illustrations below show the basic design of the valves. Constructional features, such as the shape of plugs, may differ.

### 2-port valves

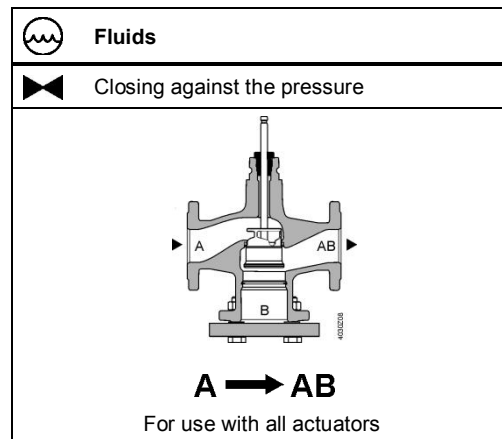

Note

**2-port valves do not become 3-port valves by removing the blank flange!**

### 3-port valves

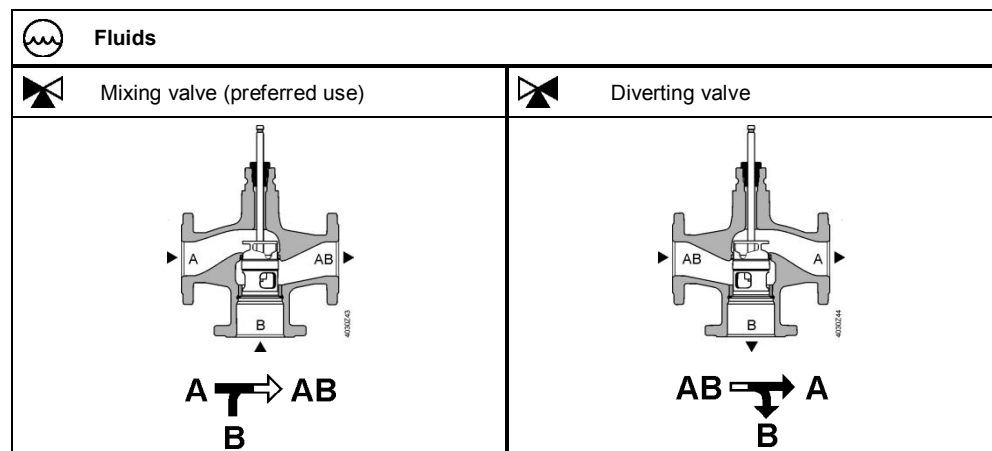

## Accessories

Product number	Stock number	Description	Note	Example
ASZ6.6	S55845-Z108	Stem heating element	Required for medium temperatures < 0 °C	

# Sizing

## Flow chart

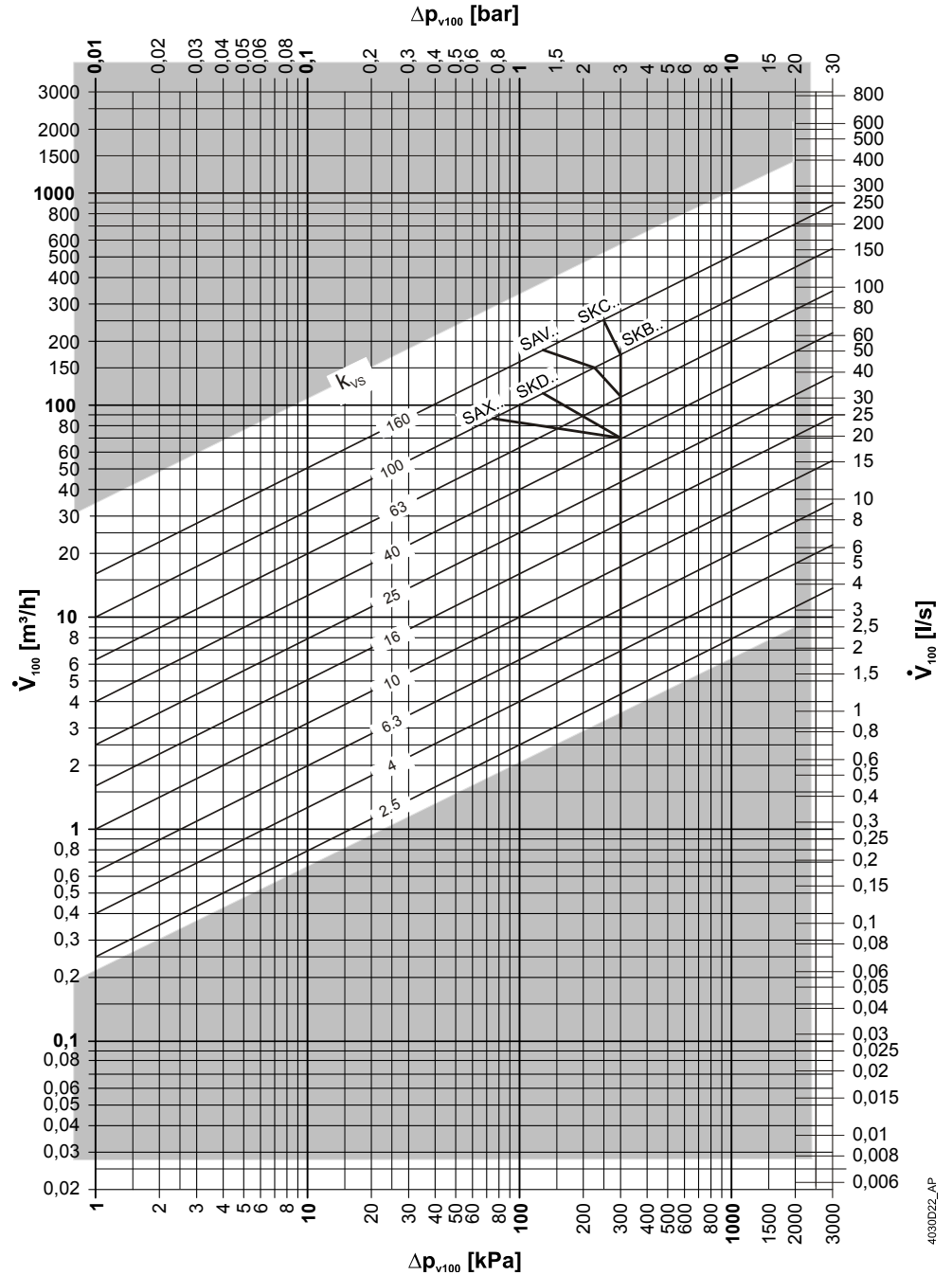

$\Delta p_{max}$  values apply for the mixing function.  $\Delta p_{max}$  values for the diverting function see table „Type summary“, page 2.

4030D22\_AP

**Valve characteristics**  
**2-port valves**

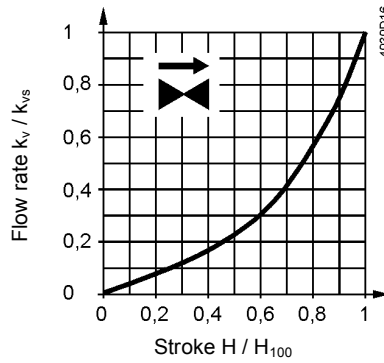

0...30%: Linear  
30...100%: Equal percentage  
 $n_{gl} = 3$  to VDI / VDE 2173

For high  $k_{vs}$  values the valve characteristic is optimized for maximum volumetric flow  $k_{V100}$ .

**3-port valves**

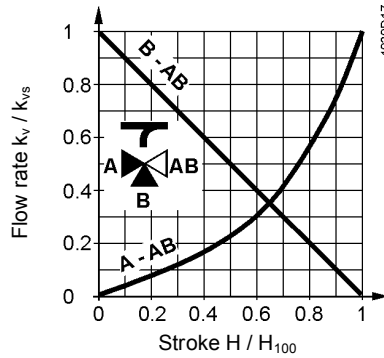

**Throughport A-AB**

0...30%: Linear  
30...100%: Equal percentage  
 $n_{gl} = 3$  to VDI / VDE 2173

For high  $k_{vs}$  values the valve characteristic is optimized for maximum volumetric flow  $k_{V100}$ .

**Bypass B-AB**

0...100%: Linear

Tor AB = constant flow

Tor A = variable flow

Tor B = bypass (variable flow)

**Mixing:** Flow from port A and port B to port AB

**Diverting:** Flow from port AB to port A and port B

**Operating pressure and medium temperature**

**Fluids, PN6 with V..F22..**

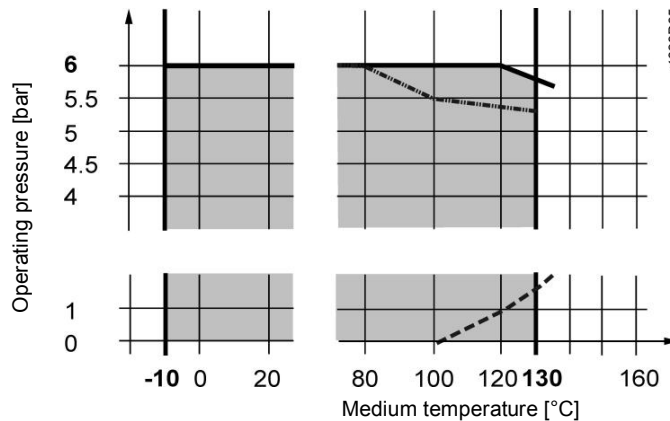

--- Curve for saturated steam; steam forms below this line

Operating pressure according to EN 1092, valid for 2-port valves with

--- blank flange

**Operating pressure and operating temperatures according to ISO 7005, EN 1092 and EN 12284**

Notes

All relevant local directives must be observed

**Medium compatibility and temperature ranges**

Medium	Temperature range		Valve	Note
	T <sub>min</sub> [°C]	T <sub>max</sub> [°C]		
Cold water	1	25	■	-
Low-temperature hot water	1	130	■	-
High-temperature hot water	130	150	-	-
Water with antifreeze	-5	130	■	For medium temperatures below 0 °C, the stem heating ASZ6.6 has to be installed.
	-10	130	■	
Brines	-5	130	■	For medium temperatures below 0 °C, the stem heating ASZ6.6 has to be installed.
	-10	130	■	
Demineralized water according to VDI2035 / SWKI_BT102-01	1	130	■	

**Fields of use**

Fields of use		Valves	
		VVF22..	VXF22..
<b>Generation</b>	Boiler plants	■	■
	Refrigeration plants	■	■
<b>Distribution</b>	Heating groups	■	■
	Ventilation and air-handling units	■	■

**Engineering notes**

- Mounting location** Preferably mount the valves at the return, as the temperature is lower there and the strain on the stem sealing gland is lower.
- Dirt trap** Mount a dirt filter or dirt trap before the valve to ensure proper functioning, and a long service life of the valve. Remove dirt, welding beads, etc. from the valves and pipes.
- Cavitation** Cavitation can be avoided by limiting the pressure differential across the valve depending on the medium temperature and prepressure.

**Mounting notes**

**Mounting position**

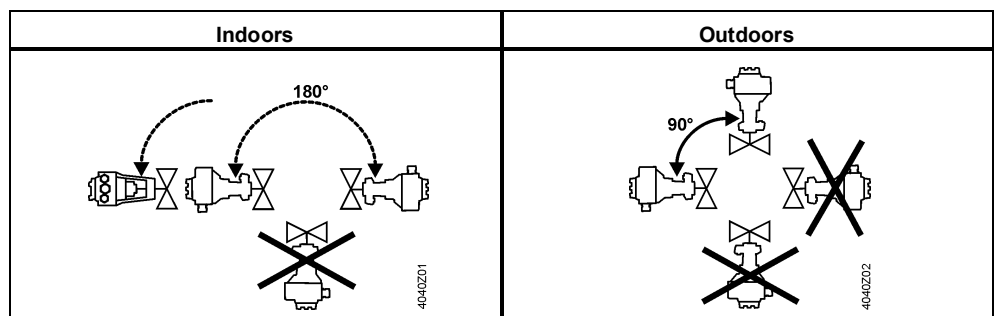

Mounting positions apply to both 2- and 3-port valves.

**Commissioning notes**



**The valve may be put into operation only if actuator and valve are correctly assembled.**

**Note**

Ensure that actuator stem and valve stem are rigidly connected in all positions.

## Function check

Valve	Throughport A→AB	Bypass B→AB
Valve stem extends	Closes	Opens
Valve stem retracts	Opens	Closes

## Maintenance notes

---

The valves are maintenance-free.



When servicing valves or actuators:

- Deactivate the pump and turn off the power supply
- Close the shutoff valves
- Fully reduce the pressure in the piping system and allow pipes to completely cool down

If necessary, disconnect the electrical wires.

Due to the different types of material used, the valve must be disassembled prior to disposal. Special handling of certain valve components may be required by law or may be sensible from an ecological point of view.

**Local and currently valid legislation must be observed.**

## Disposal



## Warranty

---

Application-related technical data are guaranteed only when the valves are used in connection with the Siemens actuators listed under "Equipment combinations", page 3.

When used with actuators of other manufacture, any warranty by Siemens becomes void.



## Technical data

Functional data	PN class	PN 6	
	Connection	Flange	
	Operating pressure	See Section "Operating pressure and medium temperature", page 6	
	Valve characteristics <sup>1)</sup>	See section "Valve characteristics", page 6	
	Leakage rate	Throughport	0...0.02% of $k_{vs}$ value
		Bypass	0.5...2% of $k_{vs}$ value ( $k_{vs} \geq 6.3$ ) 0.5...4% of $k_{vs}$ value ( $k_{vs} 2.5; 4$ )
	Permissible media	See table "Medium compatibility and temperature ranges", page 7	
	Medium temperature	-10...130 °C	
	Rangeability	To DN 25: > 50 From DN 40: >100	
	Nominal stroke	To DN 80: 20 mm From DN 100: 40 mm	
	Materials	Valve body	EN-GJL-250
Blank flange		VVF.. S235JRG2	
Valve stem		Stainless steel	
Seat		Machined	
Plug		Brass/ Bronze	
Stem sealing gland		Brass EPDM O-rings PTFE sleeve silicon-free	
Standards	Pressure Equipment Directive	PED 97/23/EC	
	Pressure-carrying accessories	According to article 1, section 2.1.4	
	Fluid group 2	PN 6	
	Without CE certification as per article 3, section 3 (sound engineering practice)	≤ DN 100	
	Category I, with CE certification	-	
	Category II, with CE certification, notified body identification number 0036	-	
	PN class	ISO 7268	
	Operating pressure	ISO 7005, DIN EN 12284	
	Flanges	ISO 7005	
	Length of flanged valves	DIN EN 558-1, line 1	
	Valve characteristic	VDI 2173 <sup>1)</sup>	
	Leakage rate	Throughport, bypass according to EN 60534-4 / EN 1349	
	Water treatment	VDI 2035	

Environmental conditions		
Storage: IEC 60721-3-1	Class	1K3
	Temperature	-15...+55 °C
	Rel. humidity	5...95% r.h.
Transport: IEC 60721-3-2	Class	2K3, 2M2
	Temperature	-30...+65 °C
	Rel. humidity	< 95% r.h.
Operation: IEC 60721-3-3	Class	3K5, 3Z11
	Temperature	-15...+55 °C
	Rel. humidity	5...95% r.h.
Environmental compatibility	ISO 14001 (environment) ISO 9001 (quality) SN 36350 (environmentally compatible products) RL 2002/95/EG (RoHS)	
Dimensions / Weight	Dimensions	See „Dimensions“, page 11
	Weight	See „Dimensions“, page 11

<sup>1)</sup> For certain valve lines and high  $k_{vS}$  values, the valve characteristic is optimized for maximum volumetric flow  $k_{V100}$ .

## Dimensions

### VVF22..

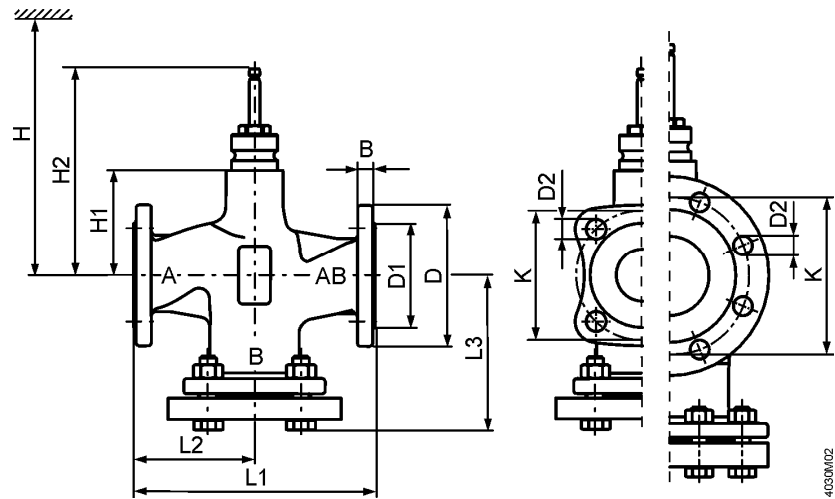

4032M/02

Product number	DN	kg	B	Ø D	Ø D1	Ø D2	L1	L2	L3	Ø K	H1	H2	H				
													SAX..	SKD..	SKB..	SAV..	SKC..
VVF22..	25	4.1	11	100	58	11 (4x)	150	75	99	75	37	133.5	479	537	612	-	-
	40	6.5	13	130	78	14 (4x)	180	90	116	100	37	133.5	479	537	612	502	-
	50	8	14	140	88	14 (4x)	200	100	128	110	50	146.5	492	550	625	515	-
	65	11.9	14	160	108	14 (4x)	240	120	142.5	130	75	171.5	517	575	650	540	-
	80	17.1	16	190	124	19 (4x)	260	130	157	150	75	171.5	517	575	650	540	-
	100	23.8	16	210	144	19 (4x)	300	150	179	170	110	226.5	-	-	-	575	685

### VXF22..

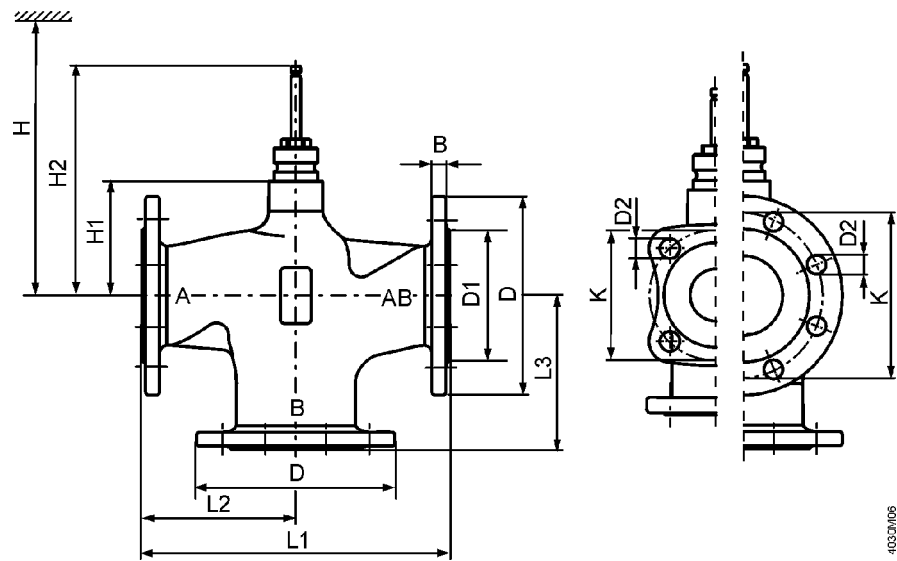

4032M/05

Product number	DN	kg	B	Ø D	Ø D1	Ø D2	L1	L2	L3	Ø K	H1	H2	H				
													SAX..	SKD..	SKB..	SAV..	SKC..
VXF22..	25	3.1	11	100	58	11 (4x)	150	75	75	75	37	133.5	479	537	612	-	-
	40	4.9	13	130	78	14 (4x)	180	90	90	100	37	133.5	479	537	612	502	-
	50	6.2	14	140	88	14 (4x)	200	100	100	110	50	146.5	492	550	625	515	-
	65	9.5	14	160	108	14 (4x)	240	120	120	130	75	171.5	517	575	650	540	-
	80	13.1	16	190	124	19 (4x)	260	130	130	150	75	171.5	517	575	650	540	-
	100	19	16	210	144	19 (4x)	300	150	150	170	110	226.5	-	-	-	575	685

## Spare parts

### Stem sealing gland

Product number	DN	Stock number	Comments	
VVF22.. VXF22..	DN 15...150	4 284 8806 0		

### Revision numbers

VVF..

VXF..

Product number	Valid from rev. no.	Product number	Valid from rev. no.
VVF22.25-2.5	..A	VXF22.25-2.5	..A
VVF22.25-4	..A	VXF22.25-4	..A
VVF22.25-6.3	..A	VXF22.25-6.3	..A
VVF22.25-10	..A	VXF22.25-10	..A
VVF22.40-16	..A	VXF22.40-16	..A
VVF22.40-25	..A	VXF22.40-25	..A
VVF22.50-40	..A	VXF22.50-40	..A
VVF22.65-63	..A	VXF22.65-63	..A
VVF22.80-100	..A	VXF22.80-100	..A
VVF22.100-160	..A	VXF22.100-160	..A